



# SNAP

terstandar, terintegrasi

## **Standar Nasional Open API Pembayaran (Standar Data dan Spesifikasi Teknis)**

Versi 1.0.2  
September 2024

## **PERNYATAAN**

Standar Nasional *Open API* Pembayaran (Standar Data dan Spesifikasi Teknis) atau disebut “Standar Nasional *Open API* Pembayaran - Standar Data dan Spesifikasi Teknis” disusun oleh ASPI dengan mempertimbangkan dan memperhatikan masukan dari pelaku industri sistem pembayaran melalui wakilnya yang berpartisipasi dalam *sub-working group* nasional *Open API* Pembayaran yang dibentuk oleh ASPI bersama dengan Bank Indonesia.

Setiap pihak yang akan menggunakan Standar Nasional *Open API* Pembayaran - Standar Data dan Spesifikasi Teknis ini sepenuhnya bertanggung jawab untuk memastikan apakah kegiatannya atau pengembangannya memerlukan persetujuan dari pihak ketiga atau memerlukan konsultasi dengan konsultan yang berkompeten sebelum menerapkan Standar Nasional *Open API* Pembayaran - Standar Data dan Spesifikasi Teknis termasuk namun tidak terbatas pada penggunaan teknologi yang mungkin digunakan secara bersamaan.

Standar Nasional *Open API* Pembayaran - Standar Data dan Spesifikasi Teknis ini dapat diubah dan/atau disesuaikan sewaktu-waktu, bila diperlukan dan setiap perubahannya dituangkan dalam dokumen perubahan Standar Nasional *Open API* Pembayaran - Standar Data dan Spesifikasi Teknis terkini.

## LEMBAR VERSI DOKUMEN

Versi	Tanggal	Penyusun	Keterangan
v.0.8.5	13-08-2021	ASPI	<p>Disusun dengan dukungan perwakilan industri sistem pembayaran-Sub <i>Working Group</i> Nasional <i>Open API</i> Pembayaran, yang terdiri dari:</p> <ul style="list-style-type: none"> <li>- PT Bank Central Asia Tbk</li> <li>- PT Bank Mandiri Tbk</li> <li>- PT Bank Nationalnobu Tbk</li> <li>- PT Bank Negara Indonesia Tbk</li> <li>- PT Bank Rakyat Indonesi Tbk</li> <li>- PT Bukalapak.com Tbk</li> <li>- PT Dompot Anak Bangsa</li> <li>- PT Espay Debit Indonesia Koe</li> <li>- PT Fintek Karya Nusantara</li> <li>- PT Midtrans</li> <li>- PT Mitra Transaksi Indonesia</li> <li>- PT Multi Adiprakarsa Manunggal</li> <li>- PT Nusa Satu Inti Artha</li> <li>- PT Shopee International Indonesia</li> <li>- PT Tokopedia</li> <li>- PT Visionet Internasional</li> </ul>
v.1.0	16-08-2021	ASPI	Berdasarkan dokumen versi 0.8.5 dari ASPI yang telah di- <i>review</i> oleh Bank Indonesia.
v.1.0.1	24-11-2021	Bank Indonesia dan ASPI	<p>Penyesuaian dilakukan berdasarkan masukan atas hasil <i>review</i> perwakilan industri sistem pembayaran-Sub <i>Working Group</i> Nasional <i>Open API</i> Pembayaran, yang terdiri dari:</p> <ul style="list-style-type: none"> <li>- PT Bank Central Asia Tbk</li> <li>- PT Bank Mandiri Tbk</li> <li>- PT Bank Nationalnobu Tbk</li> <li>- PT Bank Negara Indonesia Tbk</li> <li>- PT Bank Rakyat Indonesi Tbk</li> <li>- PT Bukalapak.com Tbk</li> <li>- PT Dompot Anak Bangsa</li> <li>- PT Espay Debit Indonesia Koe</li> <li>- PT Fintek Karya Nusantara</li> <li>- PT Midtrans</li> <li>- PT Mitra Transaksi Indonesia</li> <li>- PT Multi Adiprakarsa Manunggal</li> <li>- PT Nusa Satu Inti Artha</li> <li>- PT Shopee International Indonesia</li> <li>- PT Tokopedia</li> <li>- PT Visionet Internasional</li> </ul>
v.1.0.2	September 2024	ASPI	Revisi-1

Ringkasan Perubahan untuk Edisi Ini

No	Revisi-1	Sub-API	Revisi pada	
1	Tambah	Tambah informasi pada Description	API Get OAuth URL	Request Body
		API OTP	Request Body	
		API Request for Payment	Request Body	
		API Virtual Account – Inquiry VA	Response body	
		API Transaction Status Inquiry	Request Body & Response body	
		API Account Inquiry - Customer Top Up	Request Body	
		API Transfer to Bank-Payment Transaction	Response body	
		API Transfer to OTC – Create Payment	Response body	
		API Transfer to OTC – Transfer Status	Request Body & Response body	
		API Transfer to OTC – Cancel Payment	Response body	
		API Payment – Host to Host	Response body	
		API Cancel Payment	Response body	
		API Transaction Status Inquiry	Request Body & Response body	
		API Direct Debit Payment Status	Response body	
		API Direct Debit Payment Cancel	Response body	
		API Direct Debit Payment Refund	Response body	
		API Generate QR CPM	Request Body	
		API Query Payment	Request Body	
		API Cancel Payment	Request Body	
		API Refund Payment	Response body	
	API Auth Payment	Request Body		
	Tambah field parameter	API Intrabank Transfer	Request Body & Response body	
	a. Tambah parameter originatorInfos.	API Interbank Transfer	Request Body & Response body	
	b. Tambah parameter originatorCustomerNo.	API Interbank Bulk Transfer	Request Body	
	c. Tambah parameter originatorCustomerName	API RTGS Transfer	Request Body	
	d. Tambah paramter originatorBankCode	API SKNBI Transfer	Request Body & Response body	
	Tambah parameter baru yaitu parameter "merchantInfos"	API Decode QR MPM	Response body	
2	Ubah	Ubah Data Type dari "Datetime" menjadi "String"	API Card Registration	Request body
		API Transaction History List	Request body & Response body	
		API Transaction History Detail	Response body	
		API Bank Statement	Request body & Response body	
		API Request for Payment	Request body	
		API Registrasi e-Mandate	Request Body	
		Ubah Length dari "Format: ISO 8601" menjadi "25".	API Card Registration	Request body
		Ubah Length dari "17,3" menjadi "17,2"	API Card Registration	Request body
		Ubah parameter sesuai camelcase dari "journeyID" menjadi "journeyId".	API Card Registration – Set Limit	Request body
		Ubah Data type dari "Int" menjadi "String".	API Card Registration Unbinding	Request Body
		Ubah Mandatory dari "C O" menjadi "O".	API OTP	Request Body
		Ubah Mandatory dari "O"	API Card Registration Unbinding	Request Body
		API Account Unbinding	Response body	
		API Virtual Account - Inquiry	Request Body	

	menjadi "C"	API Virtual Account - Payment	Request Body
	Ubah Data type dari "S" menjadi "String"	API Get OAuth URL	Response body
	Ubah Mandatory dari "M" menjadi "C"	API OTP	Request Body
	Ubah Mandatory dari kosong menjadi "O"	API OTP	Request Body
	Tambah Example "54".	API OTP	Request Body
	Ubah Example dari "1" menjadi "0001"	API Balance Inquiry	Response body
	Ubah field "accountInfo" menjadi "accountInfos".	API Balance Inquiry	Contoh Response Body
	Ubah Data Type dari "ISODatetime" menjadi "String".	API Transaction History List	Request Body & Response body
		API Transaction History Detail	Response body
		API Bank Statement	Request Body & Response body
	Ubah Example dari "...-07:00" menjadi "...+07:00"	API Transaction History List	Request Body
		API Transaction History Detail	Response body
		API Bank Statement	Request Body & Response body
		API Interbank Transfer	Request Body
		API RTGS Transfer	Request Body
		API SKNBI Transfer	Request Body & Response body
		API Virtual Account – Create VA	Request Body & Response body
		API Virtual Account – Update VA	Request Body & Response body
		API Virtual Account – Update Status VA	Response body
		API Virtual Account – Inquiry VA	Response body
		API Transaction Status Inquiry	Request Body & Response body
		API Transfer to Bank-Payment Transaction	Response body
		API Transfer to OTC – Create Payment	Response body
		API Transfer to OTC – Transfer Status	Request Body & Response body
		API Transfer to OTC – Cancel Payment	Response body
		API Generate QR MPM	Request Body
		API Payment – Host to Host	Response body
		API Transaction Status Inquiry	Request Body & Response body
		API Transaction Status Inquiry	Response body
		Ubah Data Type dari "Int" menjadi "Integer".	API Transaction History List
	Ubah parameter dari "RefundAmount" menjadi "refundAmount"	API Transaction History Detail	Response body
	Ubah sesuai camelcase dari "Amount" menjadi "amount"	API Bank Statement	Response body
	Ubah Data Type dari "Object" menjadi "Array of Object".	API Bank Statement	Response body
	Ubah Object pada gambar Sequence Diagram dari "PIP GPN" menjadi "PIP GPN/BI-FAST"	API Eksternal Account Inquiry	Sectionn 4.2.1.2. Eksternal Account Inquiry
	Ubah Mandatory dari "MO" menjadi "M"	API Interbank Transfer	Request Body
	Ubah data Type dari "Array" menjadi "Array of Object".	API Interbank Bulk Transfer	Request Body
		API Interbank Bulk	Request Body

		Transfer - Notify	
	Ubah deskripsi dari "... left padding "0" ...menjadi... left padding "space"	API Virtual Account - Inquiry	Request Body & Response body
		API Virtual Account - Payment	Request Body
		API Virtual Account - Inquiry Status	Request Body & Response body
		API Virtual Account - Create VA	Request Body
		API Virtual Account - Update VA	Request Body & Response body
		API Virtual Account - Update Status VA	Request Body & Response body
	Ubah length dari "String (ISO4217)" menjadi "String"	API RTGS Notification	Request Body
		API SKNBI Transfer	Request Body & Response body
		API Notify SKNBI	Request Body
		API Virtual Account - Inquiry	Request Body & Response body
		API Virtual Account - Payment	Request Body & Response body
		API Virtual Account - Inquiry Status	Response body
		API Virtual Account - Create VA	Request Body & Response body
		API Virtual Account - Update VA	Request Body & Response body
		API Virtual Account - Update Status VA	Response body
		API Virtual Account - Get Report	Response body
		API Customer Top Up	Request Body & Response body
		API Submit Bulk Cash In	Request Body
		API Notify Bulk Cash In	Request Body
		API Transfer to Bank-Payment Transaction	Request body
		API Transfer to OTC - Create Payment	Request body
		API Transfer to Bank-Payment Transaction	Request body
	API Transfer to OTC - Create Payment	Request body	
	API Transfer to OTC - Transfer Status	Request Body & Response body	
	Ubah nama Parameter sesuai camelcase dari "BillReferenceNo" menjadi "billReferenceNo"	API Virtual Account - Payment	Request body
	Ubah HTTP Method dari "GET" menjadi "POST"	API Virtual Account - Inquiry VA	4.2.2.7 Virtual Account
	Ubah PJP AIS Lembaga Selain Bank menjadi PJP AIS di Sequence diagram	API Account Inquiry - Customer Top Up	4.3.1 API Customer Top Up
		API Customer Top Up	4.3.1 API Customer Top Up
		API Customer Top Up Inquiry Status	4.3.1 API Customer Top Up
		API Submit Bulk Cash In	4.3.2 API Bulk Cash In
		API Transfer to OTC - Transfer Status	4.3.4 API Transfer to OTC
	Ubah parameter sesuai camelcase dari "FeeAmount" menjadi "feeAmount"	API Generate QR MPM	Request Body
	Ubah Mandatory dari "C, Mandatory if redirect mode" menjadi "C"	API Decode QR MPM	Response body
	Ubah nama parameter dari "resourceType" menjadi "resourcesType"	API Payment Redirect	Contoh response
	Ubah nama parameter menjadi "externalStoreId"	API Query Payment	Request body

		Ubah nama Sub-API dari "API Payment Notify" menjadi "API Payment Notification"	API Payment Notify	4.3.5 API QR MPM
		Ubah nama Sub-API dari "Direct Debit Payment Notif" menjadi "Direct Debit Payment Notification"	API Direct Debit Payment Notify	5.2.1. API Direct Debit
		Ubah sesuai camelcase dari "externalStoreID" menjadi "externalStoreId"	API Payment Notify	Request body
			API Direct Debit Payment Notify	Request body
			API Direct Debit Payment Refund	Request body
			API Cancel Payment	Request body
			API Payment Query	Request body
API Refund	Request body			
3	Ubah Nama Sub-API	Nama Sub-API diubah dari "Notify RTGS" menjadi "RTGS Notification"	API RTGS Notification	4.2.2.5. RTGS Transfer; b. RTGS Notification
		Nama Sub-API diubah dari "Notify SKNBI" menjadi "SKNBI Notification"	API Notify SKNBI	4.2.2.6 SKNBI Transfer
4	Hapus	Hapus Description "Must be filled...".	API Card Registration	Response body
			API Card Registration – Set Limit	Response body
			API Card Registration Unbinding	Response body
			API Account Unbinding	Response body
			API Balance Inquiry	Response body
			API Transaction History List	Response body
			API Internal Account Inquiry	Request Body
			API Eksternal Account Inquiry	Response body
			API Query Payment	Request Body & Response body
			API Refund Payment	API Refund Payment
		Hapus kata "Trigger"	API Intrabank Transfer	Section 4.2.2; 4.2.2.1;
			API Interbank Transfer	4.2.2.2. Interbank Transfer
			API Interbank Bulk Transfer	4.2.2.4. Interbank Transfer - Bulk
			API Interbank Bulk Transfer - Notify	4.2.2.4. Interbank Transfer – Bulk b. Notify
5	Tambah Lampiran	Lampiran penjelasan detil revisi-1		

## DAFTAR ISI

<b>PERNYATAAN</b> .....	ii
<b>LEMBAR VERSI DOKUMEN</b> .....	iii
<b>DAFTAR ISI</b> .....	viii
<b>1. KATEGORI I: REGISTRASI</b> .....	1
<b>1.1. SKENARIO PENGGUNAAN API REGISTRATION</b> .....	1
<b>1.2. SPESIFIKASI API REGISTRATION</b> .....	5
<b>1.2.1. API Card Registration</b> .....	5
<b>1.2.2. API Card Registration – Set Limit</b> .....	14
<b>1.2.3. API Card Registration Inquiry</b> .....	17
<b>1.2.4. API Verify OTP (Direct Integration)</b> .....	20
<b>1.2.5. API Card Registration Unbinding</b> .....	26
<b>1.2.6. API Account Creation</b> .....	32
<b>1.2.7. API Account Binding</b> .....	40
<b>1.2.8. API Account Binding Inquiry</b> .....	49
<b>1.2.9. API Account Unbinding</b> .....	53
<b>1.2.10. API Get Oauth URL</b> .....	57
<b>1.2.11. OTP</b> .....	63
<b>2. KATEGORI II: INFORMASI SALDO</b> .....	68
<b>2.1. SKENARIO PENGGUNAAN API BALANCE INQUIRY</b> .....	68
<b>2.2. SPESIFIKASI API BALANCE INQUIRY</b> .....	69
<b>2.2.1. API Balance Inquiry</b> .....	69
<b>3. KATEGORI III: RIWAYAT TRANSAKSI</b> .....	77
<b>3.1. SKENARIO PENGGUNAAN API TRANSACTION HISTORY</b> .....	77
<b>3.2. SPESIFIKASI API TRANSACTION HISTORY</b> .....	80
<b>3.2.1. API Transaction History List</b> .....	80
<b>3.2.2. API Transaction History Detail</b> .....	87
<b>3.2.3. API Bank Statement</b> .....	93
<b>4. KATEGORI IV: TRANSFER KREDIT</b> .....	108
<b>4.1. SKENARIO PENGGUNAAN API TRANSFER KREDIT</b> .....	108



<b>4.2.</b>	<b>SPESIFIKASI API TRANSFER KREDIT BANK</b>	114
4.2.1.	API Account Inquiry	114
4.2.1.1.	Internal Account Inquiry	114
4.2.1.2.	Eksternal Account Inquiry	118
4.2.2.	API Transfer	122
4.2.2.1.	Intrabank Transfer	122
4.2.2.2.	Interbank Transfer	131
4.2.2.3.	Request for Payment	140
4.2.2.4.	Interbank Transfer - Bulk	146
4.2.2.5.	RTGS Transfer	160
4.2.2.6.	SKNBI Transfer	176
4.2.2.7.	Virtual Account	191
4.2.3.	API Transaction Status Inquiry	320
<b>4.3.</b>	<b>SPESIFIKASI API TRANSFER KREDIT</b>	328
4.3.1.	API Customer Top Up	328
4.3.2.	API Bulk Cash In	345
4.3.3.	API Transfer to Bank	356
4.3.4.	API Transfer to OTC	368
4.3.5.	API QR MPM	383
4.3.6.	API Transaction Status Inquiry	426
<b>5.</b>	<b>KATEGORI V: API TRANSFER DEBIT</b>	433
5.1.	SKENARIO PENGGUNAAN API TRANSFER DEBIT	433
5.2.	SPESIFIKASI API TRANSFER DEBIT	437
5.2.1.	API Direct Debit	437
5.2.2.	API QR CPM	474
5.2.3.	API Auth Payment	502
5.2.4.	API Direct Debit BI-FAST	540
<b>6.</b>	<b>Informasi Lainnya</b>	556
6.1.	Response Code	556
<b>LAMPIRAN</b>		562
	Lampiran penjelasan detil revisi-1	562

## 1. KATEGORI I: REGISTRASI

API Registration (Registrasi) diperlukan agar Konsumen dapat melakukan pengaitan datanya untuk melakukan layanan transaksi pembayaran atau mengakses data miliknya. Data-data yang dikaitkan ini dapat beragam tergantung kebutuhan, seperti data kartu debit, kartu kredit, atau rekening.

### 1.1. SKENARIO PENGGUNAAN API REGISTRASI

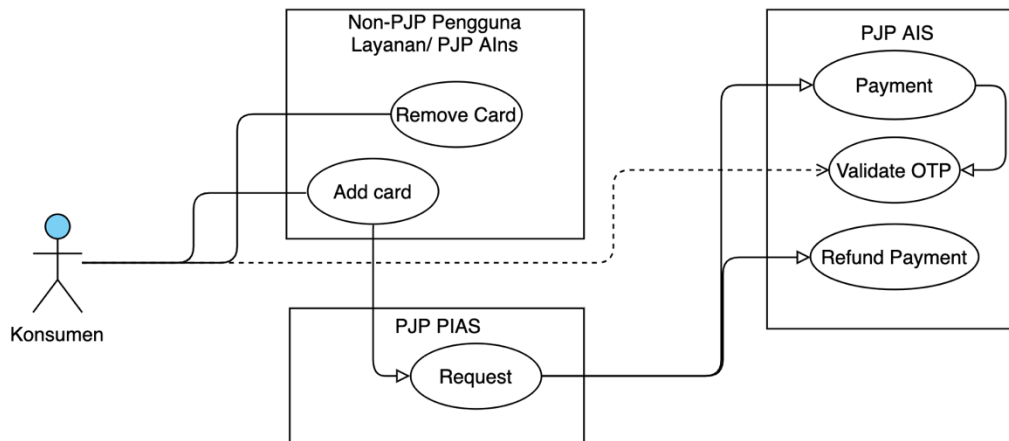

*Use Case Diagram API Card Registration (via PJP PIAS)*

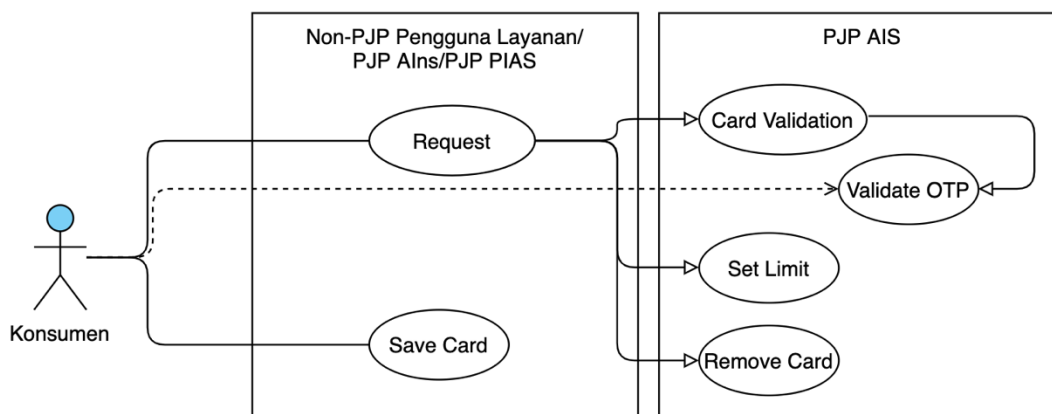

*Use Case Diagram API Card Registration (Direct Integration)*

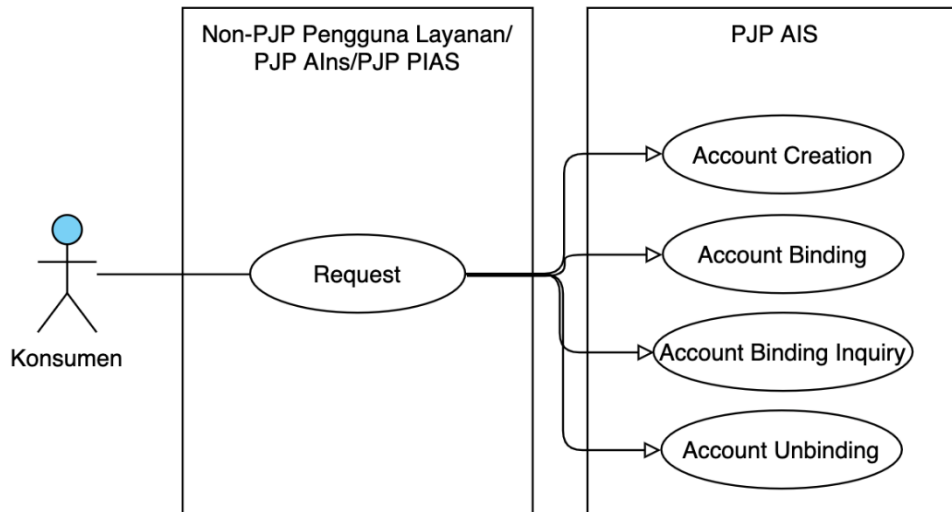

*Use Case Diagram API Account Registration*

Merujuk pada *use case diagram*, Konsumen sebagai pemilik rekening atau kartu, dapat melakukan penautan rekening atau kartunya pada Non-PJP Pengguna Layanan, PJP AIns, dan/atau PJP PIAS untuk digunakan sebagai sumber dana dalam bertransaksi dan/atau untuk mengakses layanan lainnya seperti pengecekan saldo dan/atau pengecekan histori transaksi.

API Registrasi dapat digunakan dalam sejumlah skema sebagai berikut:

**Skema 1: Indirect Integration (Konsumen – Non-PJP Pengguna Layanan / PJP AIns / PJP PIAS – PJP AIS)**

Pada skema *indirect integration*, proses *card registration* dilakukan dengan cara PJP PIAS menginisiasi pembayaran sejumlah nominal tertentu. Apabila proses otorisasi yang dilakukan PJP AIS kepada Konsumen berhasil maka dapat diyakini kebenaran informasi detail kartu dan pemiliknya, sehingga dapat dilakukan *card registration* pada Non-PJP Pengguna Layanan, PJP AIns, dan/atau PJP PIAS. Selanjutnya, PJP PIAS menginisiasi pengembalian dana atas pembayaran (*refund*).

**Skema 2: Direct Integration (Konsumen – Non-PJP Pengguna Layanan / PJP AIns / PJP PIAS – PJP AIS)**

Pada skema *direct integration*, proses *card registration* dan *account registration* dilakukan dengan cara Non-PJP Pengguna Layanan, PJP AIns, atau PJP PIAS

melakukan inisiasi validasi atas informasi kartu/rekening dan pemiliknya ke PJP AIS selaku penerbit kartu dan/atau rekening. Apabila proses validasi dan otorisasi yang dilakukan PJP AIS pada Konsumen berhasil, maka dapat diyakini kebenaran informasi detail kartu/rekening dan pemiliknya, sehingga dapat dilakukan *card registration* atau *account registration* pada Non-PJP Pengguna Layanan, PJP AIns, atau PJP PIAS.

Sejumlah API yang digunakan dalam skema-skema tersebut antara lain:

- API *Card Registration* adalah layanan yang digunakan untuk mendaftarkan data kartu milik Konsumen pada Non-PJP Pengguna Layanan, PJP AIns, atau PJP PIAS. Kartu milik Konsumen tersebut diterbitkan oleh PJP AIS dan menjadi sumber dana Konsumen dalam bertransaksi dan/atau untuk mengakses layanan lainnya. API ini dapat disediakan oleh PJP yang melakukan registrasi kartu. Dalam hubungan bisnis B2C diperlukan proses verifikasi untuk memastikan kebenaran data konsumen.

Dalam rangka melakukan validasi, dapat menggunakan mekanisme 3D Secure atau mekanisme validasi lainnya yang ditetapkan oleh penerbit kartu.

- API *Card Registration Inquiry* dapat digunakan untuk menampilkan data kartu yang sudah diregistrasikan pada Non-PJP Pengguna Layanan, PJP AIns, atau PJP PIAS. *Inquiry* dapat dilakukan dengan memberikan informasi pengenalan Konsumen.
- API *Verify OTP* merupakan API yang digunakan untuk melakukan verifikasi OTP baik untuk registrasi kartu. Verifikasi OTP ini dilakukan khususnya untuk hubungan yang melibatkan Konsumen untuk memastikan kebenaran data Konsumen yang melakukan registrasi. API ini dapat disediakan oleh PJP AIS yang menerbitkan kartu. API *Verify OTP* juga bisa digunakan untuk API Pembayaran yang menggunakan *sequence OTP*.

- *API Card Registration Unbinding* digunakan untuk melakukan penghapusan data kartu milik Konsumen yang telah diregistrasikan pada Non-PJP Pengguna Layanan, PJP AIns, atau PJP PIAS. Penghapusan data kartu dilakukan dengan memasukkan data kartu yang akan dihapuskan penautannya.
- *API Account Creation* dapat digunakan oleh Konsumen untuk pembuatan akun pada PJP AIS melalui PJP AIns, PJP PIAS, dan/atau Non-PJP Pengguna Layanan. API ini digunakan dalam hubungan *B2C (Business to Customer)*.
- *API Account Binding* adalah layanan yang digunakan untuk mendaftarkan data akun yang diterbitkan oleh PJP AIS yang menjadi sumber dana transaksi atau dalam rangka mengakses layanan lainnya oleh Konsumen pada PJP AIns dan/atau PJP PIAS. API ini digunakan dalam *B2C (Business to Customer)*. Dalam hubungan bisnis B2C diperlukan proses verifikasi/otentikasi untuk memastikan kebenaran data Konsumen.
- *API Account Binding Inquiry* dapat digunakan untuk menampilkan data rekening yang sudah diregistrasikan pada Non-PJP Pengguna Layanan, PJP AIns, dan/atau PJP PIAS. *Inquiry* dapat dilakukan dengan memberikan informasi pengenalan konsumen.
- *API Account Unbinding* digunakan untuk melakukan penghapusan data rekening milik Konsumen yang telah diregistrasikan pada Non-PJP Pengguna Layanan, PJP AIns, atau PJP PIAS. Penghapusan data rekening dilakukan dengan memasukkan data rekening yang akan dihapuskan penautannya.

Penyelenggaraan layanan pembayaran berbasis kartu termasuk pengelolaan datanya tunduk pada ketentuan yang diberlakukan oleh Penerbit/Prinsipal Kartu (seperti PCIDSS).

## 1.2. SPESIFIKASI API REGISTRATION

### 1.2.1. API Card Registration

#### Sequence Diagram

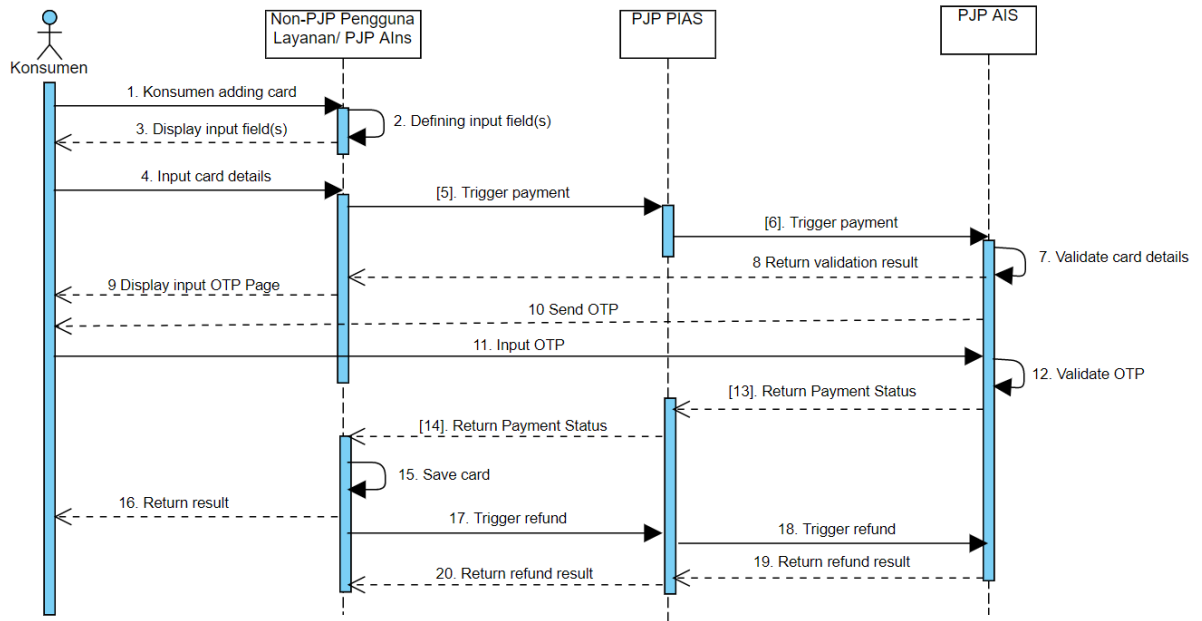

Sequence Diagram API Card Registration (via PJP PIAS)

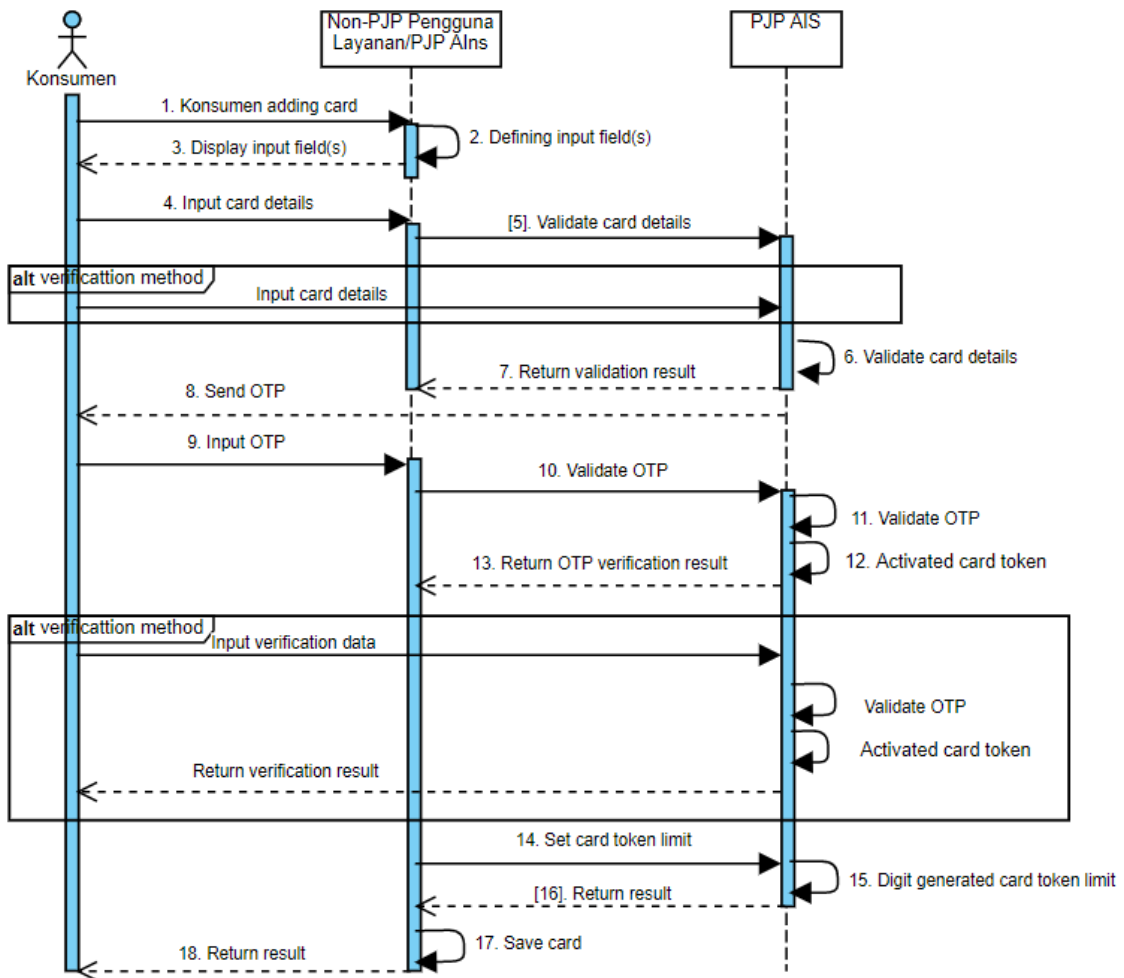

Sequence Diagram API Card Registration (Direct Integration)

## Informasi Umum

<b>Service Code</b>	01
<b>Name</b>	API Card Registration
<b>Version</b>	1.0
<b>HTTP Method</b>	POST
<b>Path</b>	.../{version}/registration-card-bind

## Request Body

<i>Parameter</i>	<i>Data Type</i>	<i>Mandatory</i>	<i>Length</i>	<i>Description</i>	<i>Example</i>
partnerReferenceNo	<i>String</i>	O	64	Transaction identifier on partner system	20201029000 00000000001
accountName	<i>String</i>	O	128	Customer's full name.	John Doe
cardData	<i>Encrypted Object</i>			Refer to Standard Symmetric Encryption on Security Standard Document section 2.1.9	
bankAccountNo	<i>String</i>	O	32	Account number	9380293840 8123
bankCardNo	<i>String</i>	M	19	Card number	39840293840 23984
bankCardType	<i>String</i>	O	2	Type of the card <b>D</b> = Debit <b>C</b> = Credit, <b>UE</b> = Uang Elektronik	D
dateOfBirth	<i>String</i>	O	8	Customer's date of birth	19900524



<b>Parameter</b>	<b>Data Type</b>	<b>Mandatory</b>	<b>Length</b>	<b>Description</b>	<b>Example</b>
				(YYYYMMDD)	
email	String	O	254	RFC 3696 Length 254 after “<” and “>”	john.doe@email.com
expiredDatetime	String	O	25	Expired date time  Format Expired date time: (ISO 8601) YYYY- MM- DDThh:mm:ss	2021-12- 03T12:08:56+ 07:00
expiryDate	String	O	4	Card expiry date. Format: MMYY	1022
identificationNo	String	O	64	Customer’s ID number	28492384090 2938402
identificationType	String	O	2	Type of ID <b>01</b> = Passport <b>02</b> = eKTP & KTP <b>03</b> = TKTP <b>04</b> =SIM (Driver’s License) <b>99</b> = Others	02
custIdMerchant	String	M	18	Merchant’s customer ID	0012345679 504

<b>Parameter</b>	<b>Data Type</b>	<b>Mandatory</b>	<b>Length</b>	<b>Description</b>	<b>Example</b>
isBindAndPay	String	O	1	Landing Page this value is always ' <b>N</b> '	N
merchantId	String	O	64	Merchant identifier that is unique per each merchant	0000710001 0926
terminalId	String	O	16	identifier that is unique per each merchant	72001126
journeyId	String	O	32	An identifier to uniquely identify a journey. On the first request of the journey, this must be equal to the X- EXTERNAL-ID.	20190329175 623MTISTORE
subMerchantId	String	O	32	Sub merchant ID	31092892494 9487
externalStoreId	String	O	64	Exkternal Store ID	0001830046 58
limit	Decimal	O	17,2	Daily transaction limit	1000000
merchantLogo Url	String	O	300	Merchant's logo URL for webview	https://bilba .test.com/dis t/img/merch ant-logo.png

<b>Parameter</b>	<b>Data Type</b>	<b>Mandatory</b>	<b>Length</b>	<b>Description</b>	<b>Example</b>
phoneNo	String	O	16	Customer's phone number Format: 62xxxxxxxxxx xxxx	6282387487 28423
sendOtpFlag	String	O	3	"YES" or "NO" to use OTP from PJSP	YES
type	String	O	20	Action type	Subscribe
additionalInfo	Object	O	N/A	Additional information for custom use that are not provided by SNAP	{"deviceId": "12345679237", "channel": "mobilephone"}

### Response Body

<b>Parameter</b>	<b>Data Type</b>	<b>Mandatory</b>	<b>Length</b>	<b>Description</b>	<b>Example</b>
responseCode	String	M	7	Response code	2000100
responseMessage	String	M	150	Response description	Successful
referenceNo	String	O	64	Transaction identifier on service provider system.	2020102977 7700000000 09

<b>Parameter</b>	<b>Data Type</b>	<b>Mandatory</b>	<b>Length</b>	<b>Description</b>	<b>Example</b>
partnerReferenceNo	String	O	64	Transaction identifier on service consumer system	2020102900 0000000000 01
bankCardToken	String	M	128	Card token for payment.	6d79636172 64746f6b65 6e
chargeToken	String	O	40	String code for verification OTP	abcd636172 64746f6b65 6e
randomString	String	O	16	Random String to generate validation for webview	g4BoEz43jfj VvAvN
tokenExpiryTime	String	O	25	Time when the token will be expired. Time when the token will be expired. Format: ISO-8601	2020-12-17T11:55:06+07:00
additionalInfo	Object	O	N/A	Additional information for custom use that are not provided by SNAP	{"deviceId": "12345679237", "channel": "mobilephone"}

## Contoh Request

```
POST .../v1.0/registration-card-bind HTTP/1.2
Content-type: application/json
Authorization: Bearer
gp9HjjEj813Y9JGoqwOeOPWbnt4CUpvIJbU1mMU4a11MNDZ7Sg5u9a"
X-TIMESTAMP: 2020-12-17T10:55:00+07:00
X-SIGNATURE:
85be817c55b2c135157c7e89f52499bf0c25ad6eebe04a986e8c86256
1b19a5
ORIGIN: www.hostname.com
X-PARTNER-ID: 82150823919040624621823174737537
X-EXTERNAL-ID: 41807553358950093184162180797837
X-IP-ADDRESS: 172.24.281.24
X-DEVICE-ID: 09864ADCASA
X-LATITUDE: -6.1617169
X-LONGITUDE: 106.6643946
CHANNEL-ID: 95221
```

```
{
  "partnerReferenceNo": "2020102900000000000001",
  "accountName": "John Doe",
  "cardData": "UIdFgZi9BhWx9Scbz/YK+JiMsPiKyhAFDaIRQe0wxMZY
hu1rn73cQfgRG11EJjZ1soevALAzajD6qm2mG47kwsjN9tcArzlVAYS/
jVflUn+zkiaMKuIxWQYJbB6MpET8Y0PjYB4aEkCvgxjPlwBcQMTVisCt
5J7NCHetYAY64ucgxhBNCpCC6cG+3nCIuGqriq8/7EwhjpZ11YcdWecJ
8glecZSv4HfjYZIFVXlwZD9rROd6xPgdKuVYVAAH8Y0pMH/x45Fouvcu
TuNIYOG26/btaUIRRnpkZsfzB4LPAk6CIQ/xia0rrWBwy479iXcV58q9
0ulic1j0tuultFRCpmobf4N6AF5XXoERr3TOb7bJyjwodTpeQy+myzCD
DidQmkKwNWoliQJdSjI+vHSi37ZfY1jlygnmaDlvQmblIj4= [SA(1]
",
  "custIdMerchant": "0012345679504",
  "isBindAndPay": "N",
  "merchantId": "00007100010926 ",
  "terminalId": "72001126",
  "journeyId": "20190329175623MTISTORE",
  "subMerchantId": "310928924949487",
  "externalStoreId": "000183004658",
  "limit": "1000000",
  "merchantLogoUrl": "https://bilba.test.com/dist/img/merch
ant-logo.png",
  "phoneNo": "08238748728423",
  "sendOtpFlag": "YES",
  "type": "subscribe",
  "additionalInfo": {
    "deviceId": "12345679237",
    "channel": "mobilephone"
  }
}
```

## Contoh Response

Content-type: application/json  
X-TIMESTAMP: 2020-12-17T10:55:06+07:00

```
{
  "responseCode": "2000100",
  "responseMessage": "Successful",
  "referenceNo": "20201029777700000000009",
  "partnerReferenceNo": "20201029000000000000001",
  "bankCardToken": "6d7963617264746f6b656e",
  "chargeToken": "abcd63617264746f6b656e",
  "randomString": "g4BoEz43jffjVvAvN",
  "tokenExpiryTime": "2020-12-17T11:00:00+07:00",
  "transactionId": "2020102020202000011001",
  {
    "deviceId": "12345679237",
    "channel": "mobilephone"
  }
}
```

## 1.2.2. API Card Registration – Set Limit

### Informasi Umum

<b>Service Code</b>	02
<b>Name</b>	API Card Registration – Set Limit
<b>Version</b>	1.0
<b>HTTP Method</b>	POST
<b>Path</b>	.../{version}/registration/card-bind-limit

### Request Body

<b>Parameter</b>	<b>Data Type</b>	<b>Mandatory</b>	<b>Length</b>	<b>Description</b>	<b>Example</b>
partnerReferenceNo	String	O	64	Transaction identifier on partner system	20201029000000000001
bankAccountNo	String	O	32	Account number	93802938408123
bankCardNo	String	O	19	Card number	3984029384023984
limit	Decimal	O	17,2	Daily transaction limit	1000000
bankCardToken	String	M	128	Card token for payment.	6d79636172647466f6b656e
otp	String	O	8	OTP Code / Passcode	12345678
additionalInfo	Object	O	N/A	Additional information for custom use that are not provided by SNAP	{"deviceId": "12345679237", "channel": "mobilephone"}

## Response Body

<b>Parameter</b>	<b>Data Type</b>	<b>Mandatory</b>	<b>Length</b>	<b>Description</b>	<b>Example</b>
responseCode	String	M	7	Response code	2000200
responseMessage	String	M	150	Response description	Successful
referenceNo	String	O	64	Transaction identifier on service provider system.	2020102977 7700000000 09
partnerReferenceNo	String	O	64	Transaction identifier on service consumer system	2020102900 0000000000 01
additionalInfo	Object	O	N/A	Additional information for custom use that are not provided by SNAP	{"deviceId": "12345679237", "channel": "mobilephone"}

## Contoh Request

```
POST .../v1.0/registration-card-inquiry HTTP/1.2
Content-type: application/json
Authorization: Bearer
gp9HjjEj813Y9JGoqwOeOPWbnt4CUpvIJbU1mMU4a11MNDZ7Sg5u9a"
X-TIMESTAMP: 2020-12-17T10:55:00+07:00
X-SIGNATURE:
85be817c55b2c135157c7e89f52499bf0c25ad6eebe04a986e8c86256
1b19a5
ORIGIN: www.hostname.com
```



```
X-PARTNER-ID: 82150823919040624621823174737537
X-EXTERNAL-ID: 41807553358950093184162180797837
X-IP-ADDRESS: 172.24.281.24
X-DEVICE-ID: 09864ADCASA
X-LATITUDE: -6.1617169
X-LONGITUDE: 106.6643946
CHANNEL-ID: 95221
{
  "partnerReferenceNo":"2020102900000000000001",
  "bankAccountNo":"93802938408123",
  "bankCardNo":"3984029384023984",
  "limit":"1000000",
  "bankCardToken":"6d7963617264746f6b656e",
  "otp":"12345678",
  "additionalInfo":{
    "deviceId":"12345679237",
    "channel":"mobilephone"
  }
}
```

### **Contoh Response**

```
Content-type: application/json
X-TIMESTAMP: 2020-12-17T10:55:06+07:00
```

```
{
  "responseCode":"2000200",
  "responseMessage":"Successful",
  "referenceNo":"20201029777700000000009",
  "partnerReferenceNo":"2020102900000000000001",
  "additionalInfo":{
    "deviceId":"12345679237",
    "channel":"mobilephone"
  }
}
```

### 1.2.3. API Card Registration Inquiry

#### Sequence Diagram

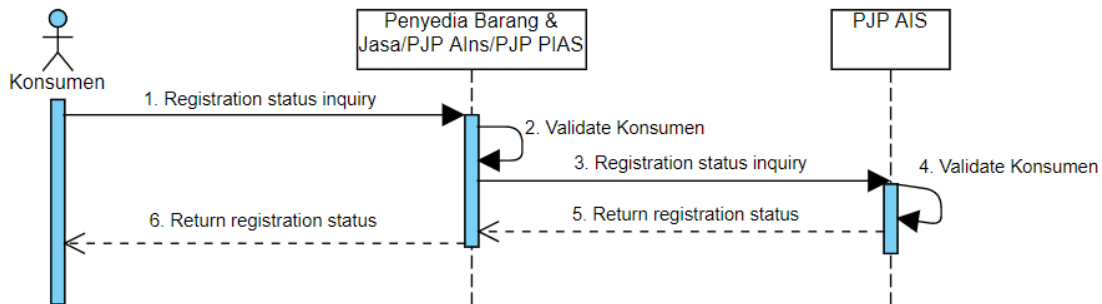

Sequence Diagram API Card Registration Inquiry

#### Informasi Umum

<b>Service Code</b>	03
<b>Name</b>	API Card Registration Inquiry
<b>Version</b>	1.0
<b>HTTP Method</b>	GET
<b>Path</b>	.../{version}/registration-card-inquiry

#### Request Parameter

<b>Parameter</b>	<b>Parameter Type</b>	<b>Data Type</b>	<b>Mandatory</b>	<b>Length</b>	<b>Description</b>	<b>Example</b>
custIdMerchant	Path param	String	M	18	Merchant's customer ID	8a95f002 6d2860f3 01

#### Response Body

<b>Parameter</b>	<b>Data Type</b>	<b>Mandatory</b>	<b>Length</b>	<b>Description</b>	<b>Example</b>
responseCode	String	M	7	Response code	2000300
responseMessage	String	M	150	Response description	Successful

<b>Parameter</b>	<b>Data Type</b>	<b>Mandatory</b>	<b>Length</b>	<b>Description</b>	<b>Example</b>
accountList	Array of Objects				
accountData	Object				
accountId	String	O	16	Account ID	F8FP2WQW EATXFP8K
createdDate	String	O	26	Creation date	2020-12- 17T10:55:0 6+07:00
credentialNo	String	O	16	Credential number	*****0 750
credentialType	String	O	2	Credential type	DC
maxLimit	String	O	6	Maximum limit	800000
status	String	O	4	Status	ACT
additionalInfo	Object	O	N/A	Additional information for custom use that are not provided by SNAP	{"deviceId": "12345679237" , "channel": "mobilephone"}

### Contoh Request

```
GET .../v1.0/registration-card-
inquiry/custIdMerchant/8a95f0026d2860f301 HTTP/1.2
Content-type: application/json
Authorization: Bearer
gp9HjjEj813Y9JGoqwOeOPWbnt4CUpvIJbU1mMU4a11MNDZ7Sg5u9a"
X-TIMESTAMP: 2020-12-17T11:43:00+07:00
X-SIGNATURE:
85be817c55b2c135157c7e89f52499bf0c25ad6eebe04a986e8c86256
1b19a5
ORIGIN: www.hostname.com
X-PARTNER-ID: 82150823919040624621823174737537
```

X-EXTERNAL-ID: 41807553358950093184162180797837  
X-IP-ADDRESS: 172.24.281.24  
X-DEVICE-ID: 09864ADCASA  
X-LATITUDE: -6.1617169  
X-LONGITUDE: 106.6643946  
CHANNEL-ID: 95221

### Contoh Response

Content-type: application/json  
X-TIMESTAMP: 2020-12-17T11:43:03+07:00

```
{
  "responseCode": "2000300",
  "responseMessage": "Successful",
  "accountList": [
    {
      "accountData": {
        "accountId": "F8FP2WQWEATXFP8K",
        "createdDate": "2018-12-17T11:59:06+07:00",
        "credentialNo": "*****0750",
        "credentialType": "DC",
        "maxLimit": "800000",
        "status": "ACT"
      }
    }
  ],
  "additionalInfo": {
    "deviceId": "12345679237",
    "channel": "mobilephone"
  }
}
```

### 1.2.4. API Verify OTP (Direct Integration)

#### Sequence Diagram

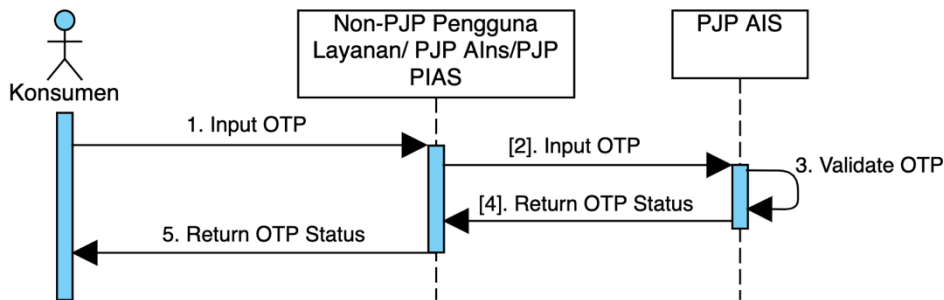

Sequence Diagram API OTP Validation (Direct Integration)

#### Informasi Umum

<b>Service Code</b>	04
<b>Name</b>	API Verify OTP (Direct Integration)
<b>Version</b>	1.0
<b>HTTP Method</b>	POST
<b>Path</b>	.../{version}/otp-verification

#### Request Body

<i>Parameter</i>	<i>Data Type</i>	<i>Mandatory</i>	<i>Length</i>	<i>Description</i>	<i>Example</i>
originalPartnerReferenceNo	String	O	64	Transaction identifier on service consumer system	20201029000000000001
originalReferenceNo	String	O	64	Transaction identifier on service provider system	2020102977770000000009
action	String	O	10	Action	otpLinkage
merchantId	String	O	64	Merchant ID	00001

<b>Parameter</b>	<b>Data Type</b>	<b>Mandatory</b>	<b>Length</b>	<b>Description</b>	<b>Example</b>
otp	String	O	8	OTP Code / Passcode	12345678
chargeToken	String	O	40	OTP string code that is to be verified with the passcode obtained by the user	TOK_TKNCPP PHUVL3IJVA XZI5GG4WBE C77YZ6::A
type	String	O	20	Action type	Subscribe
additionalInfo	Object	O	N/A	Additional information for custom use that are not provided by SNAP	{"deviceId": "12345679237", "channel": "mobile phone", "phoneNo": "0812 75647382"}

### Response Body

<b>Parameter</b>	<b>Data Type</b>	<b>Mandatory</b>	<b>Length</b>	<b>Description</b>	<b>Example</b>
responseCode	String	M	7	Response code	2000400
responseMessage	String	M	150	Response description	Successful
originalReferenceNo	String	O	64	Transaction identifier on service provider system that echo from request.	202010297 777000000 0009

<b>Parameter</b>	<b>Data Type</b>	<b>Mandatory</b>	<b>Length</b>	<b>Description</b>	<b>Example</b>
originalPartnerReferenceNo	String	O	64	Transaction identifier on service consumer system	20201029000000000001
accountNo	String	O	11	Customer's account number	12345678910
bankCardToken	String	O	128	Card token for payment	6d7963617264746f6b656e
cardPan	String	O	16	Card number	2123123123125356
customerId	String	O	45	Customer's identification	afhw6d7963617264746f6b656e963617264746f6b656e
email	String	O	254	RFC 3696 Length 254 after "<" and ">"	john.doe@email.com
expiredDatetime	String	O	25	Expired time	2019-02-24T14:12:25.871+07:00
expiryDate	String	O	4	Card expiry date. Format: MMY	1219

<b>Parameter</b>	<b>Data Type</b>	<b>Mandatory</b>	<b>Length</b>	<b>Description</b>	<b>Example</b>
identificationNo	String	O	64	registered national id number on bank account	202010202 020200001 1001
linkageToken	String	O	204	Token used for PIN redirection API	xsw56
phoneNo	String	O	16	Customer's phone number. Format: 62xxxxxxxxxxx xxx	089934567 8864332
qParamsURL	String	O	100	Webview URL to set PIN process	https://www.hostname.com/setPin
qParams	Object	O		Params used to set PIN identification	
action	String	O	10	Action type OTP	otpLinkage
sendOtpFlag	String	O	3	Flag of using PJSP's OTP or not. ("YES" or "NO")	YES
subscribeDatetime	String	O	25	Subscription time	2017-02-24T14:12:25.871+07:00
tokenExpiryTime	String	O	25	Time when	



<b>Parameter</b>	<b>Data Type</b>	<b>Mandatory</b>	<b>Length</b>	<b>Description</b>	<b>Example</b>
				the token will be expired.	2017-02-24T14:12:25.871+07:00
transactionTime stamp	String	O	25	Random String to generate validation for webview	g4BoEz43jfjVvAvN
additionalInfo	Object	O	N/A	Additional information for custom use that are not provided by SNAP	{ "deviceId": "12345679237", "channel": "mobilephone"}

### Contoh Request

```

POST .../v1.0/otp-verification HTTP/1.2
Content-type: application/json
Authorization: Bearer
gp9HjjEj813Y9JGoqwOeOPWbnt4CUpvIJbU1mMU4a11MNDZ7Sg5u9a"
X-TIMESTAMP: 2020-12-17T13:20:00+07:00
X-SIGNATURE:
85be817c55b2c135157c7e89f52499bf0c25ad6eebe04a986e8c86256
1b19a5
ORIGIN: www.hostname.com
X-PARTNER-ID: 82150823919040624621823174737537
X-EXTERNAL-ID: 41807553358950093184162180797837
X-IP-ADDRESS: 172.24.281.24
X-DEVICE-ID: 09864ADCASA
X-LATITUDE: -6.1617169
X-LONGITUDE: 106.6643946
CHANNEL-ID: 95221

{
  "originalPartnerReferenceNo": "2020102900000000000001",
  "originalReferenceNo": "2020102977770000000009",
  "action": "otpLinkage",
  "merchantId": "00001",

```

```

    "otp": "12345678",
    "chargeToken": "TOK_TKNCPPPHUVL3IJVAXZI5GG4WBEC77YZ6::A",
    "type": "Subscribe",
    "additionalInfo": {
      "deviceId": "12345679237",
      "channel": "mobilephone",
      "phoneNo": "081275647382"
    }
  }
}

```

### Contoh Response

```

Content-type: application/json
X-TIMESTAMP: 2020-12-17T13:20:04+07:00

```

```

{
  "responseCode": "2000400",
  "responseMessage": "Successful",
  "originalReferenceNo": "2020102977770000000009",
  "originalPartnerReferenceNo": "2020102900000000000001",
  "accountNo": "12345678910",
  "bankCardToken": "6d7963617264746f6b656e",
  "cardPan": "2123123123125356",
  "customerId": "afhw6d7963617264746f6b656e963617264746f6b656e",
  "email": "john.doe@email.com",
  "expiredDatetime": "2019-02-24T14:12:25.871+07:00",
  "expiryDate": "1219",
  "identificationNo": "2020102020202000011001",
  "linkageToken": "xswe56",
  "phoneNo": "0899345678864332",
  "qParamsURL": "https://setPin",
  "qParams": {
    "action": "otpLinkage"
  },
  "sendOtpFlag": "YES",
  "subscribeDatetime": "2017-02-24T14:12:25.871+07:00",
  "tokenExpiryTime": "2017-02-24T14:12:25.871+07:00",
  "transactionTimestamp": "g4BoEz43jfjVvAvN",
  "additionalInfo": {
    "deviceId": "12345679237",
    "channel": "mobilephone"
  }
}

```

### 1.2.5. API Card Registration Unbinding

#### Sequence Diagram

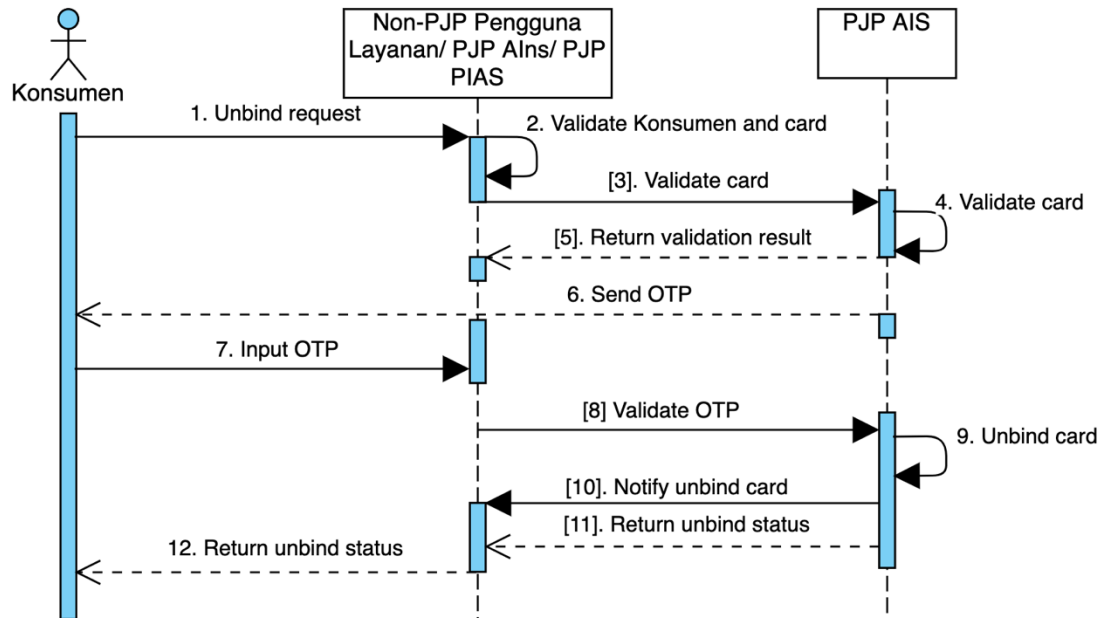

Sequence Diagram API Card Registration Unbinding

#### Informasi Umum

<b>Service Code</b>	05
<b>Name</b>	API Card Registration Unbinding
<b>Version</b>	1.0
<b>HTTP Method</b>	POST
<b>Path</b>	.../{version}/registration-card-unbind

#### Request Body

<b>Parameter</b>	<b>Data Type</b>	<b>Mandatory</b>	<b>Length</b>	<b>Description</b>	<b>Example</b>
partnerReferenceNo	String	O	64	Transaction identifier on service consumer system	20201029000000000001

<b>Parameter</b>	<b>Data Type</b>	<b>Mandatory</b>	<b>Length</b>	<b>Description</b>	<b>Example</b>
token	String	M	128	This is an alphanumeric field which contains the payment token used in a transaction. This field is used during setting token daily limit, purchase, and delete token. This token represent token number of card or token.	g4JeIz43jfjV vAvNxswe56 g4JeIz43jfjV vAvNxswe56 g4JeIz43jfjV vAvNxswe56 g4JeIz43jfjV vAvNxswe56 g4JeIz43jfjV vAvNxswe56 g4Jg4JeIz43j fdsEga
bankCardNo	String	O	19	Card number of the cardholder	2123123123 125356
type	String	O	20	Request type. Example: subscribe, unsubscribe, check OTP	Unsubscribe
part	String	O	64	Merchant identifier that is unique per each merchant	0000710001 0926

<b>Parameter</b>	<b>Data Type</b>	<b>Mandatory</b>	<b>Length</b>	<b>Description</b>	<b>Example</b>
merchantId	String	O	64	Merchant identifier that is unique per each merchant	00007100010926
subMerchantId	String	O	32	Sub merchant ID	310928924949487
terminalId	String	O	16	Identifier that is unique per each merchant	72001126
tokenRequestorId	String	O	15	An identifier to uniquely identify the token requestor.	7127425327776087324915228
journeyId	String	O	32	An identifier to uniquely identify a journey. On the first request of the journey, this must be equal to the X-EXTERNAL-ID.	20190329175623MTISTORE
transactionDate	String	O	25	Transaction date : (ISO 8601) format YYYY-MM-DDThh:mm:ss	2020-12-17T13:50:00+07:00

<b>Parameter</b>	<b>Data Type</b>	<b>Mandatory</b>	<b>Length</b>	<b>Description</b>	<b>Example</b>
additionalInfo	Object	O	N/A	Additional information for custom use that are not provided by SNAP	{ "deviceId": "12345679237", "channel": "mobilephone"}

### Response Body

<b>Parameter</b>	<b>Data Type</b>	<b>Mandatory</b>	<b>Length</b>	<b>Description</b>	<b>Example</b>
responseCode	String	M	7	Response code	2000500
responseMessage	String	M	150	Response description	Successful
referenceNo	String	O	64	Transaction identifier on service provider system.	2020102977 7700000000 09
partnerReferenceNo	String	O	64	Transaction identifier on service consumer system	2020102900 0000000000 01
message	String	O	255	Response message	Berhasil menonaktifkan biller
customerId	String	O	45	Customer ID	ae75e364134 cdb2c7a4159 106e38ca6b7

<b>Parameter</b>	<b>Data Type</b>	<b>Mandatory</b>	<b>Length</b>	<b>Description</b>	<b>Example</b>
					61983859dbv 1
unsubscribeDate	Datetime	O		Unsubscribe date. Format: ISO 8601	2020-12-17T13:50:04+07:00
additionalInfo	Object	O	N/A	Additional information for custom use that are not provided by SNAP	{"deviceId": "12345679237", "channel": "mobilephone"}

### Contoh Request

```
POST .../v1.0/registration-card-unbind HTTP/1.2
Content-type: application/json
Authorization: Bearer
gp9HjjEj813Y9JGoqwOeOPWbnt4CUpvIJbU1mMU4a11MNDZ7Sg5u9a"
X-TIMESTAMP: 2020-12-17T13:50:00+07:00
X-SIGNATURE:
85be817c55b2c135157c7e89f52499bf0c25ad6eebe04a986e8c86256
1b19a5
ORIGIN: www.hostname.com
X-PARTNER-ID: 82150823919040624621823174737537
X-EXTERNAL-ID: 41807553358950093184162180797837
X-IP-ADDRESS: 172.24.281.24
X-DEVICE-ID: 09864ADCASA
X-LATITUDE: -6.1617169
X-LONGITUDE: 106.6643946
CHANNEL-ID: 95221
```

```
{
  "partnerReferenceNo": "202010290000000000000001",
  "token":
  "g4JeIz43jffjVvAvNxsw56g4JeIz43jffjVvAvNxsw56g4JeIz43
  jffjVvAvNxsw56g4JeIz43jffjVvAvNxsw56g4JeIz43jffjVvAvNx
  sw56g4Jg4JeIz43jfdsEga",
  "bankCardNo": "2123123123125356",
  "type": "Unsubscribe",
  "part": "00007100010926",
```

```
"merchantId": "00007100010926",
"subMerchantId": "23489182303312",
"terminalId": "310928924949487",
"tokenRequestorId": "7127425327776087324915228",
"journeyId": "20190329175623MTISTORE",
"transactionDate": "2020-12-17T13:50:00+07:00",
"additionalInfo": {
  "deviceId": "12345679237",
  "channel": "mobilephone"
}
}
```

### Contoh Response

Content-type: application/json  
X-TIMESTAMP: 2020-12-17T13:50:04+07:00

```
{
  "responseCode": "2000500",
  "responseMessage": "Successful",
  "referenceNo": "20201029777700000000009",
  "partnerReferenceNo": "20201029000000000000001",
  "customerId":
  "ae75e364134cdb2c7a4159106e38ca6b761983859dbv1",
  "unsubscribeDate": "2020-12-17T13:50:04+07:00"
  "additionalInfo": {
    "deviceId": "12345679237",
    "channel": "mobilephone"
  }
}
```



## 1.2.6. API Account Creation

### Sequence Diagram

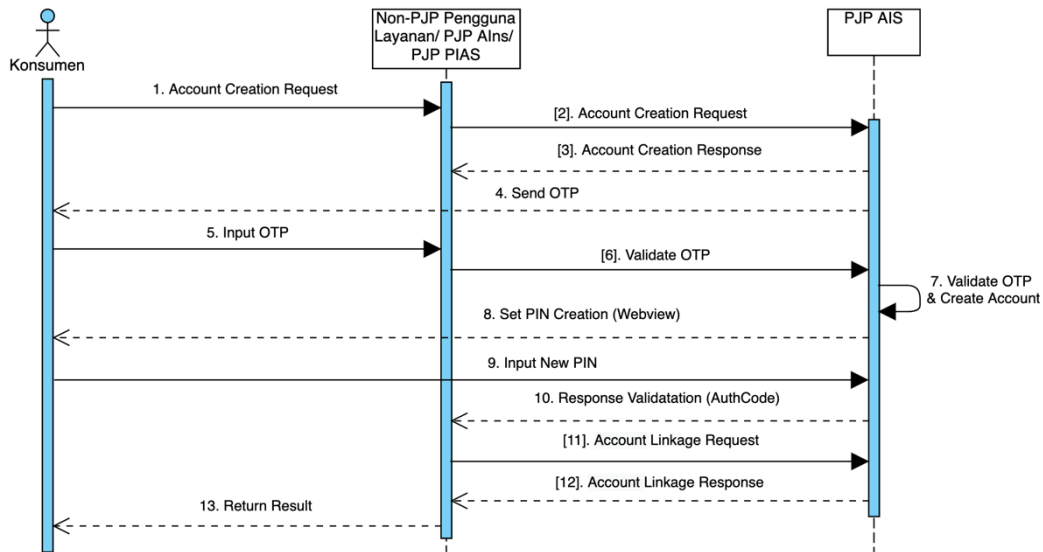

Sequence Diagram API Account Creation

### Informasi Umum

<b>Service Code</b>	06
<b>Name</b>	API Account Creation
<b>Version</b>	1.0
<b>HTTP Method</b>	POST
<b>Path</b>	.../{version}/registration-account-creation

### Request Body

<b>Parameter</b>	<b>Data Type</b>	<b>Mandatory</b>	<b>Length</b>	<b>Description</b>	<b>Example</b>
partnerReferenceNo	String	O	64	Transaction identifier on service consumer system	20201029000 00000000001
countryCode	String	O	2	Requestor's country code	ID

<b>Parameter</b>	<b>Data Type</b>	<b>Mandatory</b>	<b>Length</b>	<b>Description</b>	<b>Example</b>
customerId	String	O	45	Account ID of the customer	00- abcdefghijkl mnopqrstuv wxyz012345 6789-11
deviceInfo	Object	O	-		
os	String	O	40	Device's OS	IOS
osVersion	String	O	40	Device's OS version	1
model	String	O	40	Device's model	Iphone
manufacturer	String	O	40	Device's manufacturer	Apple
email	String	O	254	RFC 3696 Length 254 after "<" and >"	john.doe@em ail.com
lang	String	O	8	Language support parameter	ID
locale	String	O	5	Locale and language that customer selected in app	en_ID
name	String	O	128	User's name	John doe
onboardingPartner	String	O	8	Onboarding partner of the customer	GOJEKXXX

<b>Parameter</b>	<b>Data Type</b>	<b>Mandatory</b>	<b>Length</b>	<b>Description</b>	<b>Example</b>
phoneNo	String	O	16	User's phone number. Format: 62xxxxxxxxxxxx	6289934567 8864332
redirectUrl	String	O	2048	Merchant call back URL	https://merchant.site.com/apptoken
scopes	String	O	256	The scopes of the authorization	QUERY_BALANCE,QUERY_PROFILE
seamlessData	String	O	512	The structure for the mobile and verification information, the value should be URLencoded.	{ "mobile": "6288234567", "verifiedTime": "2001-07-04T12:08:56+05:30", "externalUid": "TIXxxxxxUID", "reqTime": "2001-07-04T12:08:56+05:30", "riskData": "{ "fuzzyDeviceId" ="k+OrCqw7QM NxlrT3qU2m0T RYTucd+nrMH2 izjltJgLqNI2XZ gEAAA==", "terminalType" ="APP", "riskFlag"="0010",

<b>Parameter</b>	<b>Data Type</b>	<b>Mandatory</b>	<b>Length</b>	<b>Description</b>	<b>Example</b>
					"realIp"="123.23.12.111"}
seamlessSign	String	O	512	The signature data for the seamlessData , the value should be URLencoded	URLEncode(BASE64(signin({"mobile": "6288234567", "verifiedTime": "2001-07-04T12:08:56+05:30", "externalUid": "TIXxxxxxUID", "reqTime": "2001-07-04T12:08:56+05:30", "riskData": {"fuzzyDeviceId"="k+OrCqw7QM NxlrT3qU2m0T RYTucd+nrMH2 izjtlTjgLqNI2XZgEAAA==", "terminalType"="APP", "riskFlag"="0010", "realIp"="123.23.12.111"} " } )))
state	String	O	32	State	12345556666
merchantId	String	O	64	Merchant identifier that is unique per each merchant	00007100010926

<b>Parameter</b>	<b>Data Type</b>	<b>Mandatory</b>	<b>Length</b>	<b>Description</b>	<b>Example</b>
subMerchantId	String	O	32	Sub merchant ID	3109289249 49487
terminalType	Object	O	32	Indicates the source terminal type and how the redirect will happen	SYSTEM
additionalInfo	Object	O	N/A	Additional information for custom use that are not provided by SNAP	{ "deviceId": "12345679237", "channel": "mobilephone"}

### Response Body

<b>Parameter</b>	<b>Data Type</b>	<b>Mandatory</b>	<b>Length</b>	<b>Description</b>	<b>Example</b>
responseCode	String	M	7	Response code	2000600
responseMessage	String	M	150	Response description	Successful
referenceNo	String	C	64	Transaction identifier on service provider system. Must be filled upon successful transaction	2020102977 7700000000 09

<b>Parameter</b>	<b>Data Type</b>	<b>Mandatory</b>	<b>Length</b>	<b>Description</b>	<b>Example</b>
partnerReferenceNo	String	O	64	Transaction identifier on service consumer system	202010290000000000001
authCode	String	O	64	The auth code used to get accessToken and agreementToken	g4JeIz43jfjVvAvNxswe56g4JeIz43jfjVvAvNxswe56g4JeIz43jfjVvAvNxswe56g4JeIz43jfjVvAvNxswe56g4JeIz43jfjVvAvNxswe56g4Jg4JeIz43jfdsEga
apiKey	Numeric	O	N/A	Customer ID	AB12-CD34-EFGHIJ567890
accountId	String	O	32	User's account id	ABCD1234-EF56-GH78-IJ90-KLMNOP123456
state	String	O	32	State	12345556666
additionalInfo	Object	O	N/A	Additional information for custom use that are not	{"deviceId": "12345679237", "channel": "mobilephone"}

<b>Parameter</b>	<b>Data Type</b>	<b>Mandatory</b>	<b>Length</b>	<b>Description</b>	<b>Example</b>
				provided by SNAP	

### Contoh Request

```

POST .../v1.0/registration-account-creation HTTP/1.2
Content-type: application/json
Authorization: Bearer
gp9HjjEj813Y9JGoqwOeOPWbnt4CUpvIJbU1mMU4a11MNDZ7Sg5u9a"
X-TIMESTAMP: 2020-12-17T14:49:00+07:00
X-SIGNATURE:
85be817c55b2c135157c7e89f52499bf0c25ad6eebe04a986e8c86256
1b19a5
ORIGIN: www.hostname.com
X-PARTNER-ID: 82150823919040624621823174737537
X-EXTERNAL-ID: 41807553358950093184162180797837
X-IP-ADDRESS: 172.24.281.24
X-DEVICE-ID: 09864ADCASA
X-LATITUDE: -6.1617169
X-LONGITUDE: 106.6643946
CHANNEL-ID: 95221

```

```

{
  "partnerReferenceNo": "202010290000000000000001";
  "countryCode": "ID",
  "customerId": "00-
abcdefghijklmnopqrstuvwxy0123456789-11",
  "deviceInfo": {
    "os": "IOS",
    "osVersion": "1",
    "model": "Iphone",
    "manufacture": "Apple"
  },
  "email": "john.doe@email.com",
  "lang": "ID",
  "locale": "en_ID",
  "name": "John doe",
  "onboardingPartner": "GOJEKXXX",
  "phoneNo": "0899345678864332",
  "redirectUrl": "https://merchant.site.com/apptoken",
  "scopes": "QUERY_BALANCE,QUERY_PROFILE",
  "seamlessData": {
    "mobile": "6288234567",
    "verifiedTime": "2001-07-04T12:08:56+05:30",
    "externalUid": "TIXxxxxxUID", "reqTime": "2001-
07-04T12:08:56+05:30",

```

```

        "riskData": "{
        "fuzzyDeviceId"="k+OrCqw7QMNxlrT3qU2m0TRYTucd+nrM
        H2izjtlTJgLqNI2XZgEAAA==", "terminalType"="APP",
        "riskFlag"="00110", "realIp"="123.23.12.111"}
        },
    "seamlessSign": "URLEncode(BASE64(signin({ ",
        "mobile": "6288234567",
        "verifiedTime": "2001-07-04T12:08:56+05:30",
        "externalUid": "TIXxxxxxUID",
        "reqTime": "2001-07-04T12:08:56+05:30",
        "riskData": "{
        "fuzzyDeviceId"="k+OrCqw7QMNxlrT3qU2m0TRYTucd+nrM
        H2izjtlTJgLqNI2XZgEAAA==", "terminalType"="APP",
        "riskFlag"="00110", " realIp"="123.23.12.111"}",
        })))",
    "state": "12345556666",
    "merchantId": "00007100010926",
    "subMerchantId": "310928924949487",
    "terminalType": "SYSTEM",
    "additionalInfo": {
        "deviceId": "12345679237",
        "channel": "mobilephone"
    }
}
}

```

## Contoh Response

Content-type: application/json  
X-TIMESTAMP: 2020-12-17T13:50:04+07:00

```

{
    "responseCode": "2000600",
    "responseMessage": "Successful",
    "referenceNo": "2020102977770000000009",
    "partnerReferenceNo": "2020102900000000000001",
    "authCode":
    "g4JeIz43jfjVvAvNxswe56g4JeIz43jfjVvAvNxswe56g4JeIz43j
    fjVvAvNxswe56g4JeIz43jfjVvAvNxswe56g4JeIz43jfjVvAvNxs
    e56g4Jg4JeIz43jfdsEga",
    "apiKey": "AB12-CD34-EFGHIJ567890",
    "accountId": "ABCD1234-EF56-GH78-IJ90-KLMNOP123456",
    "state": "12345556666",
    "additionalInfo": {
        "deviceId": "12345679237",
        "channel": "mobilephone"
    }
}
}

```



### 1.2.7. API Account Binding

#### Sequence Diagram

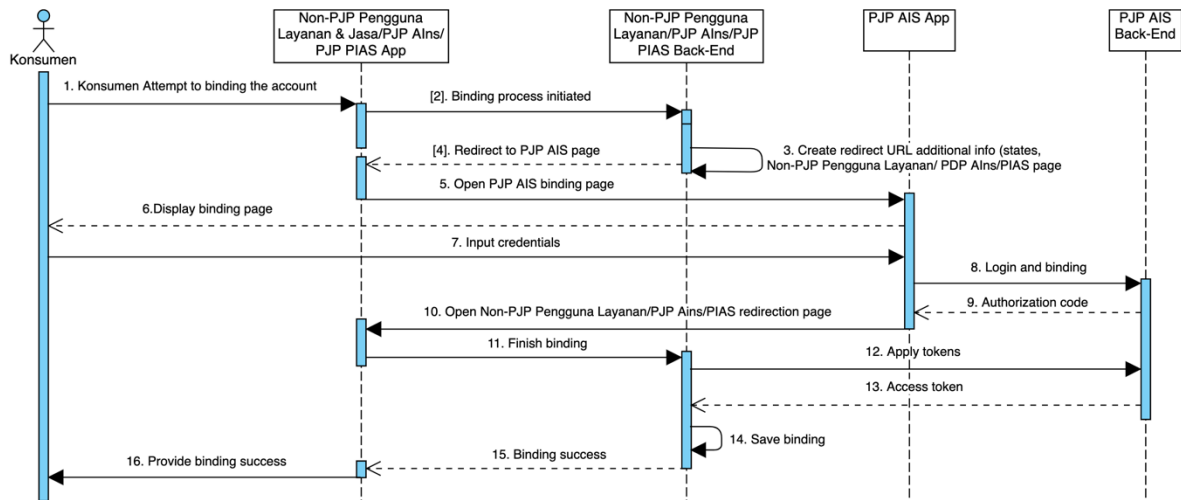

Sequence Diagram API Account Binding

#### Informasi Umum

<b>Service Code</b>	07
<b>Name</b>	API Account Binding
<b>Version</b>	1.0
<b>HTTP Method</b>	POST
<b>Path</b>	.../{version}/registration-account-binding

#### Request Body

<b>Parameter</b>	<b>Data Type</b>	<b>Mandatory</b>	<b>Length</b>	<b>Description</b>	<b>Example</b>
partnerReferenceNo	String	O	64	Transaction identifier on service consumer system	20201029000000000001
action	String	O	10	Action type for OTP	otpLinkage
additionalData	Object	O			

<b>Parameter</b>	<b>Data Type</b>	<b>Mandatory</b>	<b>Length</b>	<b>Description</b>	<b>Example</b>
userId	String	O	20	User ID of the card holder	John Doe
email	String	O	254	RFC 3696 Length 254 after "<" and ">"	john.doe@email.com
postalAddress	String	O	99	Postal address of the user	134346
authCode	String	O	64	An authorization code which the caller can used to obtain an access token.	4b203fe6c1 1548bcabd8 da5bb087a8 3b
grantType	String	O	64	The accessToken could be granted by authCode or refreshToken.	AUTHORIZA TION_CODE
isBindAndPay	String	O	1	Landing Page this value is always ' <b>N</b> '	N
lang	String	O	8	Initiate language	EN
locale	String	O	5	Locale and language that customer	en_ID

<b>Parameter</b>	<b>Data Type</b>	<b>Mandatory</b>	<b>Length</b>	<b>Description</b>	<b>Example</b>
				selected in app	
merchantId	String	M	64	Merchant identifier that is unique per each merchant	000071000 10926
subMerchantId	String	O	32	Sub merchant ID	310928924 949487
msisdn	String	O	15	Phone number to be binded	+62812345 678901
otp	String	O	8	OTP Value	34564367
phoneNo	String	O	16	User's phone number. Format: 62xxxxxxxxxx xxxx	089934567 8864332
platformType	String	O	4	Merchant platform type (App, PC, or mobile web)	app
redirectUrl	String	O	2048	Redirect URL For Agreement page or PIN page	<a href="https://www.merchantapp.com/main_page">https://www.merchantapp.com/main_page</a>
referenceId	String	O	36	Reference Id from previous	08400000814- 08400000814

<b>Parameter</b>	<b>Data Type</b>	<b>Mandatory</b>	<b>Length</b>	<b>Description</b>	<b>Example</b>
				Generate OTP	
refreshToken	String	O	64	Refresh token, which is used to refresh the access token.	201208134b 203fe6c1154 8bcabd8da5b b087a83b
successParams	Object	O	-		
accountId	string	O	36	Account ID given to the user	ABCD1234- EF56- GH78-IJ90- KLMNOP12 3456
terminalId	String	O	16	Terminal identifier	ID
tokenRequestorId	String	O	15	Token Requestor ID	e-commerce
additionalInfo	Object	O	N/A	Additional information for custom use that are not provided by SNAP	{"deviceId": "12345679237", "channel": "mobilephone"}

### Response Body

<b>Parameter</b>	<b>Data Type</b>	<b>Mandatory</b>	<b>Length</b>	<b>Description</b>	<b>Example</b>
responseCode	String	M	7	Response code	2000700
responseMessage	String	M	150	Response description	Successful

<b>Parameter</b>	<b>Data Type</b>	<b>Mandatory</b>	<b>Length</b>	<b>Description</b>	<b>Example</b>
referenceNo	String	C	64	Transaction identifier on service provider system.  Must be filled upon successful transaction	20201029777 70000000009
partnerReferenceNo	String	O	64	Transaction identifier on service consumer system	202010290000 0000000001
accountToken	String	O	128	Account Token for Payment	1Fhas7281han862=
accessTokenInfo	Object	O	-		
accessToken	String	O	32	Access token	ublicpBa869cad0990e4e17a57ecf7c5469a4b2
expiresIn	String	O	25	Datetime of token expiration. Format: ISO 8601	2021-07-04T12:08:56+05:30
refreshToken	String	O	64	Refresh token, which is used	201208134b203fe6c11548

<b>Parameter</b>	<b>Data Type</b>	<b>Mandatory</b>	<b>Length</b>	<b>Description</b>	<b>Example</b>
				to refresh the access token.	bcabd8da5bb087a83b
reExpiresIn	String	O	25	Datetime of refresh token expiration. Format: ISO 8601	2051-07-04T12:08:56+05:30
tokenStatus	String	O	25	Status of token	ACTIVE
linkId	String	O	24	Identifier provided at the time of linking	abcd1234efgh5678ijkl9012
nextAction	String	O	255	Redirect the user to this url for authentication	https://gopayapi.com/validate/otp/abcd123456789
linkageToken	String	O	204	Token used for PIN redirection API	xswe56
params	Object	O	-	Params used for set PIN identification	
action	String	O	10	Action type OTP	otpLinkage
pinWebViewUrl	String	O	100	URL for set PIN process	https://www.merchant.com/setPin
redirectToDeep link	String	O	255	Redirect the user to this deeplink in app for	https://www.merchantapi.com/redirect

<b>Parameter</b>	<b>Data Type</b>	<b>Mandatory</b>	<b>Length</b>	<b>Description</b>	<b>Example</b>
				authentication . This is only valid in case of App Redirection Flow	/abcd123456789
redirectUrl	String	O	2048	Redirect URL For Agreement page or PIN page	https://www.merchantapi.com/redirect/abcd123456789
userInfo	Object	O	-		
publicUserId	String	O	20	User ID	20180626111215830192DANAW3ID965200060630
additionalInfo	Object	O	N/A	Additional information for custom use that are not provided by SNAP	{"deviceId": "12345679237", "channel": "mobilephone"}

### Contoh Request

```

POST .../v1.0/registration-account-binding HTTP/1.2
Content-type: application/json
Authorization: Bearer
gp9HjjEj813Y9JGoqwOeOPWbnt4CUpvIJbU1mMU4a11MNDZ7Sg5u9a"
X-TIMESTAMP: 2020-12-18T13:43:31+07:00
X-SIGNATURE:
85be817c55b2c135157c7e89f52499bf0c25ad6eebe04a986e8c86256
1b19a5
ORIGIN: www.hostname.com
X-PARTNER-ID: 82150823919040624621823174737537
X-EXTERNAL-ID: 41807553358950093184162180797837

```

X-IP-ADDRESS: 172.24.281.24  
X-DEVICE-ID: 09864ADCASA  
X-LATITUDE: -6.1617169  
X-LONGITUDE: 106.6643946  
CHANNEL-ID: 95221

```
{
  "partnerReferenceNo": "202010290000000000000001",
  "action": "otpLinkage",
  "additionalData": {
    "userId": "John Doe",
    "email": "john.doe@email.com",
    "postalAddress": "134346"
  },
  "authCode": "4b203fe6c11548bcabd8da5bb087a83b",
  "grantType": "AUTHORIZATION_CODE",
  "isBindAndPay": "N",
  "lang": "EN",
  "locale": "en_ID",
  "merchantId": "00007100010926",
  "subMerchantId": "310928924949487",
  "msisdn": "+62812345678901",
  "otp": "34564367",
  "phoneNo": "0899345678864332",
  "platformType": "app",
  "redirectUrl": "merchantapp://main_page",
  "referenceId": "08400000814-08400000814",
  "refreshToken":
"201208134b203fe6c11548bcabd8da5bb087a83b ",
  "successParams": {
    "accountId": "ABCD1234-EF56-GH78-IJ90-
KLMNOP123456"
  },
  "terminalId": "ID",
  "tokenRequestorId": "e-commerce",
  "additionalInfo": {
    "deviceId": "12345679237",
    "channel": "mobilephone"
  }
}
```

### Contoh Response

Content-type: application/json  
X-TIMESTAMP: 2020-12-18T13:43:37+07:00  
X-SIGNATURE:  
85be817c55b2c135157c7e89f52499bf0c25ad6eebe04a986e8c862561  
b19a5

```
{
  "responseCode": "2000700",
```



```
"responseMessage": "Successful",
"referenceNo": "2020102977770000000009",
"partnerReferenceNo": "2020102900000000000001",
"accountToken": "1Fhas7281han862=",
"accessTokenInfo": {
  "accessToken": "ublicpBa869cad0990e4e17a57ecf7c5469a4b2",
  "expiresIn": "2021-07-04T12:08:56+05:30",
  "refreshToken": "201208134b203fe6c11548bcabd8da5bb087a83b",
  "reExpiresIn": "2051-07-04T12:08:56+05:30",
  "tokenStatus": "ACTIVE"
},
"linkId": "abcd1234efgh5678ijkl9012",
"nextAction": "https://gopayapi.com/validate/otp/abcd123456789",
"linkageToken": "xswe56",
"params": {
  "action": "otpLinkage",
  "pinWebViewUrl": "https://setPin",
  "redirectToDeeplink": "https://gopayapi.com/redirect/gopay/abcd123456789"
},
"redirectUrl": "https://www.merchantapi.com/redirect/abcd123456789",
"userInfo": {
  "publicUserId": "20180626111215830192DANAW3ID965200060630"
},
"additionalInfo": {
  "deviceId": "12345679237",
  "channel": "mobilephone"
}
}
```

### 1.2.8. API Account Binding Inquiry

#### Sequence Diagram

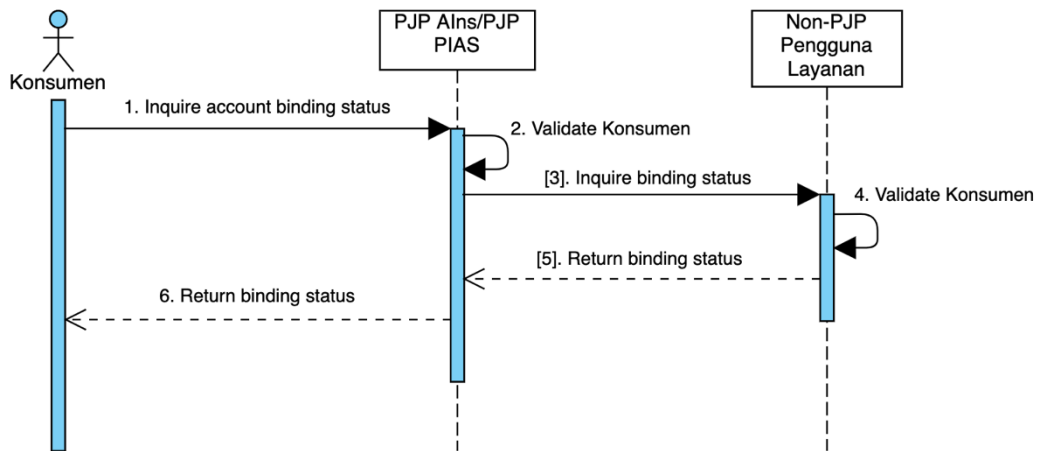

Sequence Diagram API Account binding inquiry

#### Informasi Umum

<b>Service Code</b>	08
<b>Name</b>	API Account Binding Inquiry
<b>Version</b>	1.0
<b>HTTP Method</b>	POST
<b>Path</b>	.../{version}/registration-account-inquiry

#### Request Body

<b>Parameter</b>	<b>Data Type</b>	<b>Mandatory</b>	<b>Length</b>	<b>Description</b>	<b>Example</b>
partnerReferenceNo	String	O	64	Transaction identifier on service consumer system	20201029000000000001
additionalInfo	Object	O	N/A	Additional information for custom use that are	{"deviceId": "12345679237", "channel": "mobilephone"}

<b>Parameter</b>	<b>Data Type</b>	<b>Mandatory</b>	<b>Length</b>	<b>Description</b>	<b>Example</b>
				not provided by SNAP	

### **Response Body**

<b>Parameter</b>	<b>Data Type</b>	<b>Mandatory</b>	<b>Length</b>	<b>Description</b>	<b>Example</b>
responseCode	<i>String</i>	<i>M</i>	7	Response code	2000800
responseMessage	<i>String</i>	<i>M</i>	150	Response description	Successful
referenceNo	<i>String</i>	<i>C</i>	64	Transaction identifier on service provider system.  Must be filled upon successful transaction	20201029777 70000000009
partnerReferenceNo	<i>String</i>	<i>O</i>	64	Transaction identifier on service consumer system	20201029000 00000000001
accountCurrency	<i>String</i>	<i>O</i>	3	Currency of registered Account	IDR

<b>Parameter</b>	<b>Data Type</b>	<b>Mandatory</b>	<b>Length</b>	<b>Description</b>	<b>Example</b>
accountName	String	O	50	Registered account name	Alen Mjucic
accountNo	String	O	13	Registered account number	11231271284140
accountTransactionLimit	Numeric	O	19,2	Max debit amount	1000000
endDatePeriod	String	O	10	Binding end period. Format: YYYY-MM-DD	2022-05-21
startDatePeriod	String	O	10	Binding start period. Format: YYYY-MM-DD	2020-05-21
additionalInfo	Object	O	N/A	Additional information for custom use that are not provided by SNAP	{"deviceId": "12345679237", "channel": "mobilephone"}

### Contoh Request

```
POST .../v1.0/registration-account-inquiry HTTP/1.2
Content-type: application/json
Authorization: Bearer
gp9HjjEj813Y9JGoqwOeOPWbnt4CUpvIJbU1mMU4a11MNDZ7Sg5u9a"
X-TIMESTAMP: 2020-12-18T14:39:21+07:00
```

X-SIGNATURE:  
85be817c55b2c135157c7e89f52499bf0c25ad6eebe04a986e8c86256  
1b19a5  
ORIGIN: www.hostname.com  
X-PARTNER-ID: 82150823919040624621823174737537  
X-EXTERNAL-ID: 41807553358950093184162180797837  
X-IP-ADDRESS: 172.24.281.24  
X-DEVICE-ID: 09864ADCASA  
X-LATITUDE: -6.1617169  
X-LONGITUDE: 106.6643946CHANNEL-ID: 95221

```
{
  "partnerReferenceNo": "2020102900000000000001",
  "additionalInfo": {
    "deviceId": "12345679237",
    "channel": "mobilephone"
  }
}
```

### Contoh Response

Content-type: application/json  
X-TIMESTAMP: 2020-12-18T14:39:30+07:00

```
{
  "responseCode": "2000800",
  "responseMessage": "Successful",
  "referenceNo": "20201029777700000000009",
  "partnerReferenceNo": "202010290000000000000001",
  "accountCurrency": "IDR",
  "accountName": "Alen Miucic",
  "accountNo": "11231271284140",
  "accountTransactionLimit": "1000000",
  "endDatePeriod": "2022-05-21",
  "startDatePeriod": "2020-05-21",
  "additionalInfo": {
    "deviceId": "12345679237",
    "channel": "mobilephone"
  }
}
```

### 1.2.9. API Account Unbinding

#### Sequence Diagram

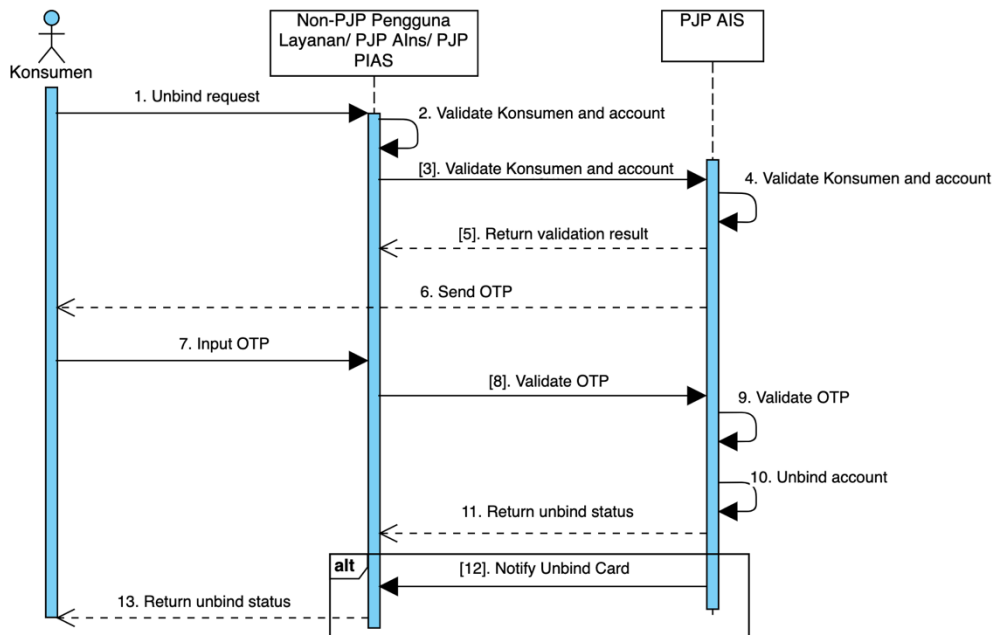

Sequence Diagram API Account Unbinding

#### Informasi Umum

<b>Service Code</b>	09
<b>Name</b>	API Account Unbinding
<b>Version</b>	1.0
<b>HTTP Method</b>	POST
<b>Path</b>	.../{version}/registration-account-unbinding

#### Request Body

<b>Parameter</b>	<b>Data Type</b>	<b>Mandatory</b>	<b>Length</b>	<b>Description</b>	<b>Example</b>
partnerReferenceNo	String	0	64	Transaction identifier on service consumer system	20201029000000000001

<b>Parameter</b>	<b>Data Type</b>	<b>Mandatory</b>	<b>Length</b>	<b>Description</b>	<b>Example</b>
linkId	String	O	24	Identifier provided at the time of linking	abcd1234efg h5678ijk190 12
merchantId	String	M	64	Merchant identifier that is unique per each merchant	0000710001 0926
subMerchantId	String	O	32	Sub Merchant ID	3109289249 49487
tokenId	String	O	128	Access Token ID	Aeox320xvij wefop10
additionalInfo	Object	O	N/A	Additional information for custom use that are not provided by SNAP	{"deviceId": "12345679237", "channel": "mobilephone"}

### Response Body

<b>Parameter</b>	<b>Data Type</b>	<b>Mandatory</b>	<b>Length</b>	<b>Description</b>	<b>Example</b>
responseCode	String	M	7	Response code	2000900
responseMessage	String	M	150	Response description	Successful
referenceNo	String	O	64	Transaction identifier on service	2020102977 7700000000 09

<b>Parameter</b>	<b>Data Type</b>	<b>Mandatory</b>	<b>Length</b>	<b>Description</b>	<b>Example</b>
				provider system.	
partnerReferenceNo	String	O	64	Transaction identifier on service consumer system	20201029000000000001
merchantId	String	O	64	Merchant identifier that is unique per each merchant	00007100010926
subMerchantId	String	O	32	Sub merchant ID	310928924949487
linkId	String	O	24	Identifier provided at the time of linking	abcd1234efgh5678ijkl9012
unlinkResult	String	O	64	Result of unlinking process	success
additionalInfo	Object	O	N/A	Additional information for custom use that are not provided by SNAP	{“deviceId”: “12345679237”, “channel”: “mobilephone”}

### Contoh Request

```
POST .../v1.0/registration-account-unbinding HTTP/1.2
Content-type: application/json
Authorization: Bearer
gp9HjjEj813Y9JGoqwOeOPWbnt4CupvIJbU1Mmu4a11MNDZ7Sg5u9a"
```



X-TIMESTAMP: 2020-12-18T14:48:11+07:00  
X-SIGNATURE:  
85be817c55b2c135157c7e89f52499bf0c25ad6eebe04a986e8c86256  
1b19a5  
ORIGIN: [www.hostname.com](http://www.hostname.com)  
X-PARTNER-ID: 82150823919040624621823174737537  
X-EXTERNAL-ID: 41807553358950093184162180797837  
X-IP-ADDRESS: 172.24.281.24  
X-DEVICE-ID: 09864ADCASA  
X-LATITUDE: -6.1617169  
X-LONGITUDE: 106.6643946  
CHANNEL-ID: 95221

```
{
  "partnerReferenceNo":"202010290000000000000001",
  "linkId":"abcd1234efgh5678ijkl9012",
  "merchantId":"00007100010926",
  "subMerchantId":"310928924949487",
  "tokenId":"Aeox320xvijwefop10",
  "additionalInfo":{
    "deviceId":"12345679237",
    "channel":"mobilephone"
  }
}
```

## Contoh Response

Content-type: application/json  
X-TIMESTAMP: 2020-12-18T14:48:30+07:00

```
{
  "responseCode":"2000900",
  "responseMessage":"Successful",
  "referenceNo":"202010297777000000000009",
  "partnerReferenceNo":"202010290000000000000001",
  "merchantId":"00007100010926",
  "subMerchantId":"310928924949487",
  "linkId":"abcd1234efgh5678ijkl9012",
  "unlinkResult":"success",
  "additionalInfo":{
    "deviceId":"12345679237",
    "channel":"mobilephone"
  }
}
```

### 1.2.10. API Get Oauth URL

#### Informasi Umum

<b>Service Code</b>	10
<b>Name</b>	API Get Oauth URL
<b>Version</b>	1.0
<b>HTTP Method</b>	GET
<b>Path</b>	../{version}/get-auth-code

#### Request Parameter

<i>Parameter</i>	<i>Data Type</i>	<i>Mandatory</i>	<i>Length</i>	<i>Description</i>	<i>Example</i>
redirectUrl	String	M	256	URL yang digunakan sebagai callback setelah proses getCode berhasil.	<a href="https://domain.com/authSuccess.js">https://domain.com/authSuccess.js</a>
scopes	List<String>	M	256	Scope akses dari authorization yang diinginkan.	QUERY_BALANCE,QUERY_PROFILE
state	String	M	32	Random string untuk keperluan perlindungan terhadap CSRF	W0dkkwijSDs
merchantId	String	O	64	Merchant identifier that is	00007100010926

<b>Parameter</b>	<b>Data Type</b>	<b>Mandatory</b>	<b>Length</b>	<b>Description</b>	<b>Example</b>
				unique per each merchant	
subMerchantId	<i>String</i>	O	32	Sub merchant ID	310928924949487
lang	<i>String</i>	O	2	Kode Bahasa yang layanan. ISO 639-1	id
allowRegistration	<i>Boolean</i>	O		If value equals true, provider may enable registration process during binding.  Default True.	True
seamlessData	<i>String</i>	O	512	Data yang diperuntukan untuk mempercepat proses otentikasi	
mobileNumber	<i>String</i>	O	18	Nomor telpon pengguna, apabila field ini terisi maka user wajin login dengan nomor yang	62822999999

<b>Parameter</b>	<b>Data Type</b>	<b>Mandatory</b>	<b>Length</b>	<b>Description</b>	<b>Example</b>
				sudah disertakan	
verifiedTime	String	O	25	Value yang menyatakan bahwa nomor ponsel yang sudah disertakan dalam seamless data sudah diverifikasi kepemilikannya dan tidak memerlukan verifikasi OTP oleh pihak penyedia. Validitas dari verifikasi ini hanya 10 menit.  Format verified time: (ISO 8601) YYYY-MM-DDThh:mm:ss	2051-07-04T12:08:56+05:30
externalUid	String	O	32	ID milik user pada aplikasi partner	31345354453
deviceId	String	O	32	Device ID milik User	

<i>Parameter</i>	<i>Data Type</i>	<i>Mandatory</i>	<i>Length</i>	<i>Description</i>	<i>Example</i>
seamlessSign	String	C	512	Signature dari seamless data yang disertakan.  Harus diisi jika seamless data tersedia.	

Cara menyertakan seamless data:

```
seamlessData = URLEncode({"mobileNumber"="62822999999"})
```

Cara menyertakan seamlessSign:

```
seamlessSign = URLEncode(sign(seamlessData))
```

- Partner menggunakan private key untuk membuat seamless sign, sedangkan pihak penyedia akan menggunakan public key milik partner untuk proses verifikasi.
- Jika proses verifikasi gagal, maka seamless data akan diabaikan.
- Charset dari URL Encode menggunakan UTF-8

Konstruksi URL

```
../{version}/get-auth-code?state=<RANDOM_UNIQUE>&scopes=QUERY_BALANCE,PUBLIC_ID&redirectUrl=<MERCHANT_OAUTH_CALLBACK_URL>&seamlessData=<SEAMLESS_DATA>&seamlessSign=<SIGNATURE>
```

## Response Body

<b>Parameter</b>	<b>Data Type</b>	<b>Mandatory</b>	<b>Length</b>	<b>Description</b>	<b>Example</b>
responseCode	String	M	7	Response code	2001000
responseMessage	String	M	150	Response description	Successful
authCode	String	M	256	Authcode yang dapat ditukarkan dengan access token pada API account binding	a4sd5a4fsaf5d5f4df66ad85f4
state	String	M	32	Random string untuk keperluan perlindungan terhadap CSRF	W0dkkwijSDs

## Contoh Request

```
GET .../v1.0/get-auth-code?state=W0dkkwijSDs
&scopes=QUERY_BALANCE,PUBLIC_ID&redirectUrl=https://domain
.com/authSuccess.htm&seamlessData=%7B%22mobileNumber%22%3A
%2262822999999999%22%7D&seamlessSign=gsfIUuC%2Bzs101rRFUhz
z9753s9Dj4wg0EtwLwr8fMhZmCFybaCcwvAXGZ0RDxqzb9fJuFre%2Bmsi
9JcwHICVx%2FB1onruQNldI4Y%2BUZqVQLgUVz1ynAalqyyaTKliXOfy3t
%2FbOhXd0QfZ3e1zbQT5
Content-type: application/json
Authorization: Bearer
gp9HjjEj813Y9JGoqwOeOPWbnt4CupvIJbU1Mmu4a11MNDZ7Sg5u9a"
Authorization-Customer: Bearer
fa8sjjEj813Y9JGoqwOeOPWbnt4CupvIJbU1Mmu4a11MNDZ7Sg5u9a"
X-TIMESTAMP: 2020-12-23T09:10:11+07:00
X-SIGNATURE:
85be817c55b2c135157c7e89f52499bf0c25ad6eebe04a986e8c86256
1b19a5
```

ORIGIN: www.hostname.com  
X-PARTNER-ID: 82150823919040624621823174737537  
X-EXTERNAL-ID: 41807553358950093184162180797837  
X-IP-ADDRESS: 172.24.281.24  
X-DEVICE-ID: 09864ADCASA  
X-LATITUDE: -6.108841  
X-LONGITUDE: 106.7782137  
CHANNEL-ID: 95221

### **Contoh Response**

Content-type: application/json  
X-TIMESTAMP: 2020-12-23T09:10:18+07:00

```
{  
  "responseCode": "2001000",  
  "responseMessage": "Successful",  
  "authCode": "a4sd5a4fsaf5d5f4df66ad85f4",  
  "state": "WodkkwijSDs"  
}
```

### 1.2.11. OTP

#### Sequence Diagram

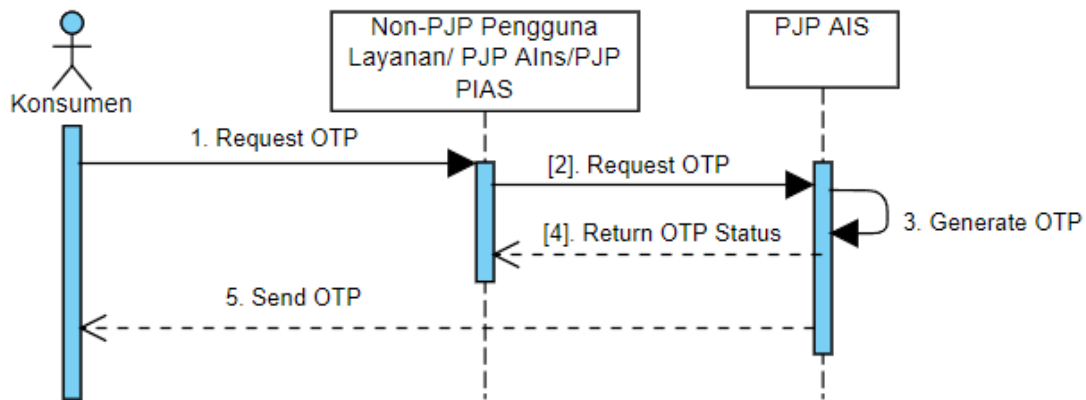

Sequence Diagram API OTP

#### Informasi Umum

<b>Service Code</b>	81
<b>Name</b>	API OTP
<b>Version</b>	1.0
<b>HTTP Method</b>	POST
<b>Path</b>	.../{version}/otp

#### Request Body

<b>Parameter</b>	<b>Data Type</b>	<b>Mandatory</b>	<b>Length</b>	<b>Description</b>	<b>Example</b>
partnerReferenceNo	String	O	64	Transaction identifier on partner system	20201029000000000001
journeyId	String	M	32	An identifier to uniquely identify a journey. On the first request of the journey, this must be	20190329175623MTIS TORE



<b>Parameter</b>	<b>Data Type</b>	<b>Mandatory</b>	<b>Length</b>	<b>Description</b>	<b>Example</b>
				equal to the X-EXTERNAL-ID.	
merchantId	String	O	64	Merchant ID	00001
subMerchant	String	O	32	Sub merchant ID	310928924 949487
externalStoreId	String	O	64	External Store ID	124928924 949487
trxDateTime	Date	O	25	PJP internal system datetime with timezone, which follows the ISO-8601 standard	2020-12-21T14:56:11+07:00
bankCardToken	String	C	128	Card token for payment.  If binding process is using card, then this field must be filled with the value of bankCardToken or, If binding process is using account, then this field must be filled with the value of accountToken.	6d7963617 264746f6b6 56e
otpTrxCode	String	O	2	Purpose of otp.  This will be used to retry	54

<b>Parameter</b>	<b>Data Type</b>	<b>Mandatory</b>	<b>Length</b>	<b>Description</b>	<b>Example</b>
				OTP with service code of the original transaction request.	
otpReasonCode	String	O	2		
otpReasonMessage	String	O	30		
additionalInfo	Object	O	N/A	Additional information for custom use that are not provided by SNAP	{"deviceId": "12345679237", "channel": "mobilephone"}

### Response Body

<b>Parameter</b>	<b>Data Type</b>	<b>Mandatory</b>	<b>Length</b>	<b>Description</b>	<b>Example</b>
responseCode	String	M	7	Response code	2008100
responseMessage	String	M	150	Response description	Successful
referenceNo	String	O	64	Transaction identifier on service provider system.	2020102977 7700000000 09
partnerReferenceNo	String	O	64	Transaction identifier on service	2020102900 0000000000 01

<b>Parameter</b>	<b>Data Type</b>	<b>Mandatory</b>	<b>Length</b>	<b>Description</b>	<b>Example</b>
				consumer system	
chargeToken	String	M	40	string code for verification OTP	abcd6361726 4746f6b656e
additionalInfo	Object	O	N/A	Additional information for custom use that are not provided by SNAP	{"deviceId": "12345679237", "channel": "mobile phone", "phoneNo": "081275647382"}

### Contoh Request

```

POST .../v1.0/otp HTTP/1.2
Content-type: application/json
Authorization: Bearer
gp9HjjEj813Y9JGoqwOeOPWbnt4CUpvIJbU1mMU4a11MNDZ7Sg5u9a"
Authorization-Customer: Bearer
fa8sjjEj813Y9JGoqwOeOPWbnt4CUpvIJbU1mMU4a11MNDZ7Sg5u9a"
X-TIMESTAMP: 2020-12-22T07:53:16+07:00
X-SIGNATURE:
85be817c55b2c135157c7e89f52499bf0c25ad6eebe04a986e8c86256
1b19a5
ORIGIN: www.hostname.com
X-PARTNER-ID: 82150823919040624621823174737537
X-EXTERNAL-ID: 41807553358950093184162180797837
X-IP-ADDRESS: 172.24.281.24
X-DEVICE-ID: 09864ADCASA
X-LATITUDE: -6.1617169
X-LONGITUDE: 106.6643946
CHANNEL-ID: 95221

```

```

{
  "partnerReferenceNo": "202010290000000000000001",
  "journeyID": "20190329175623MTISTORE",
  "merchantId": "00001",
  "subMerchant": "310928924949487",
  "externalStoreId": "124928924949487",
  "trxDateTime": "2020-12-21T14:56:11+07:00",

```

```
"bankCardToken":"6d7963617264746f6b656e",
"otpTrxCode":"54",
"otpReasonCode":"","
"otpReasonMessage":"","
"additionalInfo":{
  "deviceId":"12345679237",
  "channel":"mobilephone"
}
}
```

### Contoh Response

Content-type: application/json  
X-TIMESTAMP: 2020-12-22T07:53:21+07:00

```
{
  "responseCode":"2008100",
  "responseMessage":"Successful",
  "referenceNo":"20201029777700000000009",
  "partnerReferenceNo":"20201029000000000000001",
  "chargeToken":"abcd63617264746f6b656e",
  "additionalInfo":{
    "deviceId":"12345679237",
    "channel":"mobilephone"
  }
}
```

## 2. KATEGORI II: INFORMASI SALDO

API Balance Inquiry (Informasi Saldo) diperlukan agar Konsumen, Non-PJP Pengguna Layanan, PJP Ains, maupun PJP PIAS dapat mengakses informasi saldo terkini dari rekening yang dimiliki secara *real time*, sesuai dengan layanan yang disediakan oleh PJP AIS.

### 2.1. SKENARIO PENGGUNAAN API BALANCE INQUIRY

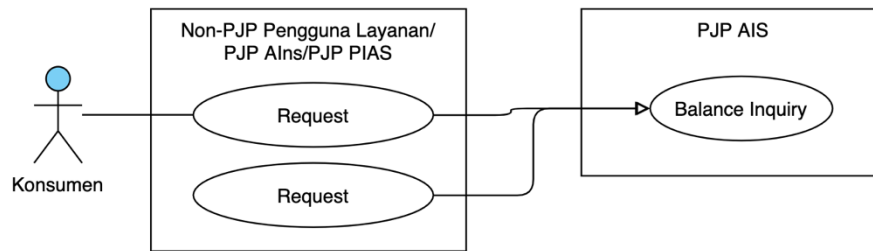

*Use Case Diagram API Balance Inquiry*

Merujuk pada *use case diagram*, pemilik akun yaitu Konsumen, Non-PJP Pengguna Layanan, PJP Ains, serta PJP PIAS, dapat mengakses informasi saldo atas rekeningnya menggunakan API Balance Inquiry yang disediakan oleh PJP AIS.

API Balance Inquiry dapat digunakan dalam sejumlah skema sebagai berikut:

#### **Skema 1: Konsumen – Non-PJP Pengguna Layanan / PJP Ains / PJP PIAS – PJP AIS**

Dalam skema ini, Konsumen mengakses informasi saldo rekeningnya melalui Non-PJP Pengguna Layanan, PJP Ains, atau PJP PIAS yang terhubung ke PJP AIS dimana rekening Konsumen terdaftar. Mekanisme ini dapat dilakukan menggunakan *authorization code* yang didapat dari proses *card registration* atau *account binding* dengan melalui proses otorisasi/otentikasi untuk memastikan kebenaran informasi Konsumen dengan menggunakan mekanisme Oauth 2.0.

#### **Skema 2: Non-PJP Pengguna Layanan / PJP Ains / PJP PIAS – PJP AIS**

Dalam skema ini, Non-PJP Pengguna Layanan, PJP Ains, atau PJP PIAS mengakses informasi saldo rekeningnya pada PJP AIS dimana rekening Non-PJP Pengguna Layanan, PJP Ains, atau PJP PIAS terdaftar.

## 2.2. SPESIFIKASI API BALANCE INQUIRY

### 2.2.1. API Balance Inquiry

#### Sequence Diagram

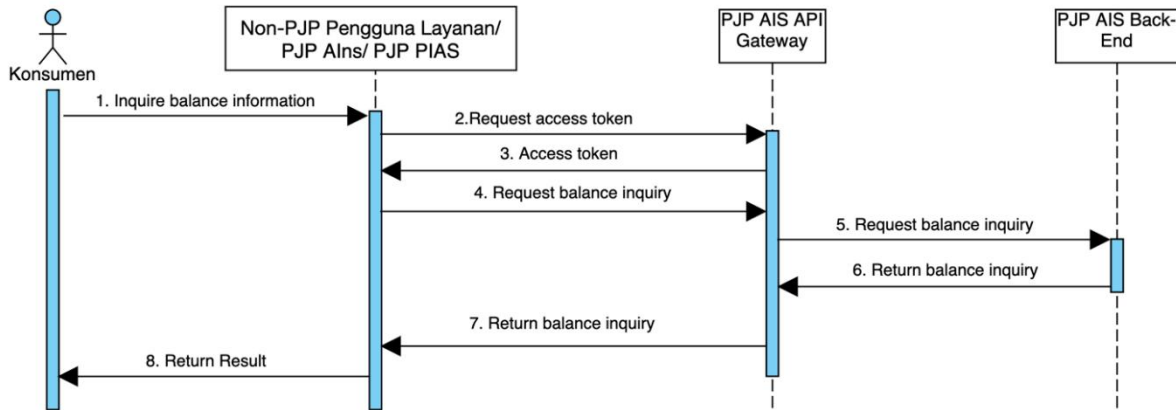

Sequence Diagram API Balance Inquiry

#### Informasi Umum

<b>Service Code</b>	11
<b>Name</b>	API Balance Inquiry
<b>Version</b>	1.0
<b>HTTP Method</b>	POST
<b>Path</b>	.../{version}/balance-inquiry

#### Request Body

<b>Parameter</b>	<b>Data Type</b>	<b>Mandatory</b>	<b>Length</b>	<b>Description</b>	<b>Example</b>
partnerReferenceNo	String	O	64	Transaction identifier on service consumer system	20201029000 00000000001
bankCardToken	String	C	128	Card token for payment. Must be filled if accountNo and customer token	6d796361726 4746f6b656e

<b>Parameter</b>	<b>Data Type</b>	<b>Mandatory</b>	<b>Length</b>	<b>Description</b>	<b>Example</b>
				(Token B2B2C) are both Null	
accountNo	String	C	16	Bank account number.  Must be filled if bankCardToken and customer token (Token B2B2C) are both Null	73823829578 93840
balanceTypes	Array of Strings	O		Balance Types of this parameter doesn't exist, its mean to inquiry all Balance Type on the account	["Cash", "Coins"]
additionalInfo	Object	O	N/A	Additional information	{"deviceId": "12345679237", "channel": "mobilephone"}

### Response Body

<b>Parameter</b>	<b>Data Type</b>	<b>Mandatory</b>	<b>Length</b>	<b>Description</b>	<b>Example</b>
responseCode	String	M	7	Response code	2001100
responseMessage	String	M	150	Response description	Successful

<b>Parameter</b>	<b>Data Type</b>	<b>Mandatory</b>	<b>Length</b>	<b>Description</b>	<b>Example</b>
referenceNo	String	O	64	Transaction identifier on service provider system.	2020102977 7700000000 09
partnerReferenceNo	String	O	64	Transaction identifier on service consumer system	2020102900 0000000000 01
accountNo	String	O	32	Registered account number	115471119
name	String	O	140	Customer account name	JONOMADE
accountInfos	Array of Objects	O			
balanceType	String	O	70	Account type name	Balance, Ovo Cash, Shopee Coins
amount	Object	O			
value	String	M	16,2	Net amount of the transaction. If it's IDR then value includes 2 decimal digits. e.g. IDR 10.000,- will	200000.00



<b>Parameter</b>	<b>Data Type</b>	<b>Mandatory</b>	<b>Length</b>	<b>Description</b>	<b>Example</b>
				be placed with 10000.00	
currency	String	M	3	Currency (ISO 4217)	IDR
floatAmount	Object	O			
value	String	M	16,2	Amount of deposit that is not effective yet (due to holiday, etc.). If it's IDR then value includes 2 decimal digits. e.g. IDR 50.000,- will be placed with 50000.00	50000.00
currency	String	M	3	Currency (ISO 4217)	IDR
holdAmount	Object	O			
value	String	M	16,2	Hold amount that cannot be used. If it's IDR then value includes 2 decimal digits. e.g. IDR 20.000,- will	20000.00

<b>Parameter</b>	<b>Data Type</b>	<b>Mandatory</b>	<b>Length</b>	<b>Description</b>	<b>Example</b>
				be placed with 20000.00	
currency	String	M	3	Currency (ISO 4217)	IDR
availableBalance	Object	O			
value	String	M	16,2	Account balance that can be used for financial transaction	130000.00
currency	String	M	3	Currency (ISO 4217)	IDR
ledgerBalance	Object	O			
value	String	M	16,2	Account balance at the beginning of each day	30000.00
currency	String	M	3	Currency (ISO 4217)	IDR
currentMultilateralLimit	Object	O			
value	String	M	16,2	Credit limit of the account / plafon	10000.00
currency	String	M	3	Currency (ISO 4217)	IDR
registration StatusCode	String	O	4	Customer registration status	0001

<b>Parameter</b>	<b>Data Type</b>	<b>Mandatory</b>	<b>Length</b>	<b>Description</b>	<b>Example</b>
status	String	O	4	Account Status  <b>0001</b> = Active Account <b>0002</b> = Closed Account <b>0004</b> = New Account <b>0006</b> = Restricted Account <b>0007</b> = Frozen Account <b>0009</b> = Dormant Account	0001
additionalInfo	Object	O	N/A	Additional information for custom use that are not provided by SNAP	{"deviceId": "12345679237", "channel": "mobilephone"}

### Contoh Request

```
POST .../v1.0/balance-inquiry HTTP/1.2
Content-type: application/json
Authorization: Bearer
gp9HjjEj813Y9JGoqwOeOPWbnt4CUpvIJbU1mMU4a11MNDZ7Sg5u9a"
Authorization-Customer: Bearer
fa8sjjEj813Y9JGoqwOeOPWbnt4CUpvIJbU1mMU4a11MNDZ7Sg5u9a"
X-TIMESTAMP: 2020-12-18T15:06:00+07:00
```

X-SIGNATURE:  
85be817c55b2c135157c7e89f52499bf0c25ad6eeeb04a986e8c86256  
1b19a5  
ORIGIN: www.hostname.com  
X-PARTNER-ID: 82150823919040624621823174737537  
X-EXTERNAL-ID: 41807553358950093184162180797837  
X-IP-ADDRESS: 172.24.281.24  
X-DEVICE-ID: 09864ADCASA  
X-LATITUDE: -6.1617169  
X-LONGITUDE: 106.6643946  
CHANNEL-ID: 95221

```
{
  "partnerReferenceNo":"2020102900000000000001",
  "bankCardToken":"6d7963617264746f6b656e",
  "accountNo":"7382382957893840",
  "balanceType":["Cash","Coins"],
  "additionalInfo":{
    "deviceId":"12345679237",
    "channel":"mobilephone"
  }
}
```

## Contoh Response

Content-type: application/json  
X-TIMESTAMP: 2020-12-18T15:06:07+07:00

```
{
  "responseCode":"2001100",
  "responseMessage":"Successful",
  "referenceNo":"20201029777700000000009",
  "partnerReferenceNo":"2020102900000000000001",
  "accountNo":"115471119",
  "name":"JONOMADE",
  "accountInfos":[
    {
      "balanceType":"Cash",
      "amount":{
        "value":"200000.00",
        "currency":"IDR"
      },
      "floatAmount":{
        "value":"50000.00",
        "currency":"IDR"
      },
      "holdAmount":{
        "value":"20000.00",
        "currency":"IDR"
      },
      "availableBalance":{
```

```

        "value": "130000.00",
        "currency": "IDR"
    },
    "ledgerBalance": {
        "value": "30000.00",
        "currency": "IDR"
    },
    "currentMultilateralLimit": {
        "value": "10000.00",
        "currency": "IDR"
    },
    "registrationStatusCode": "0001",
    "status": "0001"
},
{
    "balanceType": "Coins",
    "amount": {
        "value": "200000.00",
        "currency": "IDR"
    },
    "floatAmount": {
        "value": "50000.00",
        "currency": "IDR"
    },
    "holdAmount": {
        "value": "20000.00",
        "currency": "IDR"
    },
    "availableBalance": {
        "value": "130000.00",
        "currency": "IDR"
    },
    "ledgerBalance": {
        "value": "30000.00",
        "currency": "IDR"
    },
    "currentMultilateralLimit": {
        "value": "10000.00",
        "currency": "IDR"
    },
    "registrationStatusCode": "0001",
    "status": "0001"
}
],
"additionalInfo": {
    "deviceId": "12345679237",
    "channel": "mobilephone"
}
}

```

### 3. KATEGORI III: RIWAYAT TRANSAKSI

API Transaction History (Riwayat Transaksi) diperlukan agar Konsumen, Non-PJP Pengguna Layanan, atau PJP PIAS dapat mengakses informasi riwayat transaksi dari rekening yang dimiliki secara *real time*, sesuai dengan layanan yang disediakan oleh PJP AIS. Informasi riwayat transaksi berisi rincian mengenai transaksi kredit maupun debit, saldo rekening, dan beberapa informasi lainnya.

API Bank Statement merupakan API yang digunakan untuk mengakses riwayat transaksi keuangan secara menyeluruh dari sebuah rekening Bank, baik rekening milik individu pemilik rekening. Konsumen dapat memanfaatkan *platform* dari Non-PJP Pengguna Layanan, atau PJP PIAS yang telah disertifikasi oleh PJP AIS untuk mengakses API ini sehingga dapat dengan mudah melihat rincian keuangannya dalam satu aplikasi.

#### 3.1. SKENARIO PENGGUNAAN API TRANSACTION HISTORY

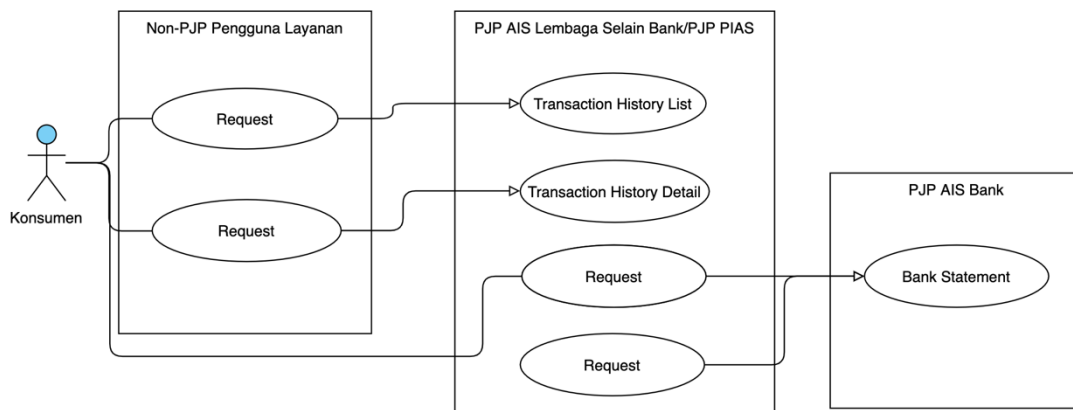

*Use Case Diagram API Transaction History*

Merujuk pada *use case diagram*, pemilik akun yaitu Konsumen, Non-PJP Pengguna Layanan, PJP PIAS, PJP AIS Lembaga Selain Bank dapat mengakses informasi riwayat transaksi (transaction history list) dan/atau rincian dari riwayat transaksi (transaction history detail) atas rekeningnya menggunakan API Riwayat Transaksi yang disediakan oleh PJP PIAS atau PJP AIS. Konsumen, PJP PIAS, atau PJP AIS Lembaga Selain Bank dapat menggunakan

API Bank Statement yang disediakan oleh PJP AIS melalui pihak yang sudah tersertifikasi untuk mengakses API ini.

API Transaction History dapat digunakan dalam sejumlah skema sebagai berikut:

**Skema 1: Konsumen – Non-PJP Pengguna Layanan – PJP AIS Lembaga Selain Bank**

Dalam skema ini, Konsumen mengakses riwayat transaksi yang tercatat pada PJP AIS Lembaga Selain Bank yang dilakukan melalui Non-PJP Pengguna Layanan sebagai kanal pembayaran. Mekanisme ini dapat dilakukan setelah dilakukan proses *card registration/account binding*. Pada saat pengaksesan riwayat transaksi, diperlukan permintaan persetujuan Konsumen (otorisasi/otentikasi) secara eksplisit menggunakan mekanisme OAuth 2.0 untuk memastikan kebenaran informasi Konsumen serta agar tidak ada penyalahgunaan data dan hak dari Konsumen. Setelah mendapatkan persetujuan dari Konsumen, Non-PJP Pengguna Layanan akan mendapatkan access token sebagai credential dari PJP AIS Lembaga Selain Bank untuk mengakses data Konsumen tersebut.

Dalam skema ini, Konsumen dapat mengakses riwayat transaksi yang transaksinya dilakukan melalui PJP AIS Lembaga Selain Bank dan Non-PJP Pengguna Layanan tersebut saja. Dalam hal ini, PJP AIS Lembaga Selain Bank tidak menyertakan riwayat transaksi yang dilakukan melalui kanal pembayaran lain.

API yang dapat digunakan dalam skema ini adalah API *Transaction History List* dan *Transaction History Detail*. API *Transaction History List* mengembalikan daftar riwayat transaksi, sedangkan API *Transaction History Detail* mengembalikan informasi lengkap dari 1 riwayat transaksi.

**Skema 2: Konsumen – Non-PJP Pengguna Layanan – PJP PIAS**

Dalam skema ini, Konsumen mengakses riwayat transaksi yang tercatat pada PJP PIAS yang dilakukan melalui suatu Non-PJP Pengguna Layanan sebagai

kanal pembayaran. PJP PIAS pada umumnya menyediakan beberapa kanal pembayaran seperti kartu kredit/debit, transfer ke *virtual account*, hingga pembayaran *offline* pada tempat tertentu seperti minimarket.

Konsumen tidak memiliki akun khusus pada PJP PIAS dan Konsumen memasukkan beberapa informasi setiap kali melakukan transaksi. Konsumen dapat mengakses riwayat transaksi yang dilakukan pada Non-PJP Pengguna Layanan tersebut dengan menggunakan API *Transaction History List* dan *Transaction History Detail*. Non-PJP Pengguna Layanan cukup menggunakan *credentials* yang telah disediakan oleh PJP PIAS.

### **Skema 3: Konsumen – PJP PIAS – PJP AIS Bank**

Dalam skema ini, Konsumen mengakses riwayat transaksi melalui layanan rekening koran pada PJP AIS Bank yang dilakukan melalui PJP PIAS sebagai kanal pembayaran. Konsumen dapat mengakses riwayat transaksi yang dilakukan dengan menggunakan API Bank Statement.

API ini hanya bisa digunakan oleh pihak yang sudah tersertifikasi dan lolos pemeriksaan oleh PJP AIS Bank sebagai penyedia layanan karena mengandung data pribadi dan rahasia.

Pada saat pengaksesan riwayat transaksi, diperlukan permintaan persetujuan Konsumen (otorisasi/otentikasi) secara eksplisit menggunakan mekanisme OAuth 2.0 untuk memastikan kebenaran informasi pengguna serta agar tidak ada penyalahgunaan data.

Setelah mendapatkan persetujuan dari Konsumen, PJP PIAS akan mendapatkan *access token* sebagai *credential* dari PJP AIS Bank untuk mengakses data.

### **Skema 4: PJP AIS Lembaga Selain Bank/PJP PIAS – PJP AIS Bank**

Dalam skema ini, PJP AIS Lembaga Selain Bank/PJP PIAS dapat mengakses riwayat transaksi rekeningnya melalui layanan rekening koran pada PJP AIS Bank dengan menggunakan API Bank Statement.



### 3.2. SPESIFIKASI API TRANSACTION HISTORY

#### 3.2.1. API Transaction History List

Ketentuan dan Keterbatasan API

<b>Pengurutan</b>	DESC
<b>pageSize Maksimal</b>	50
<b>Rentang Waktu Maksimal</b>	1 bulan
<b>Riwayat Transaksi Tertua</b>	1 tahun

#### Sequence Diagram

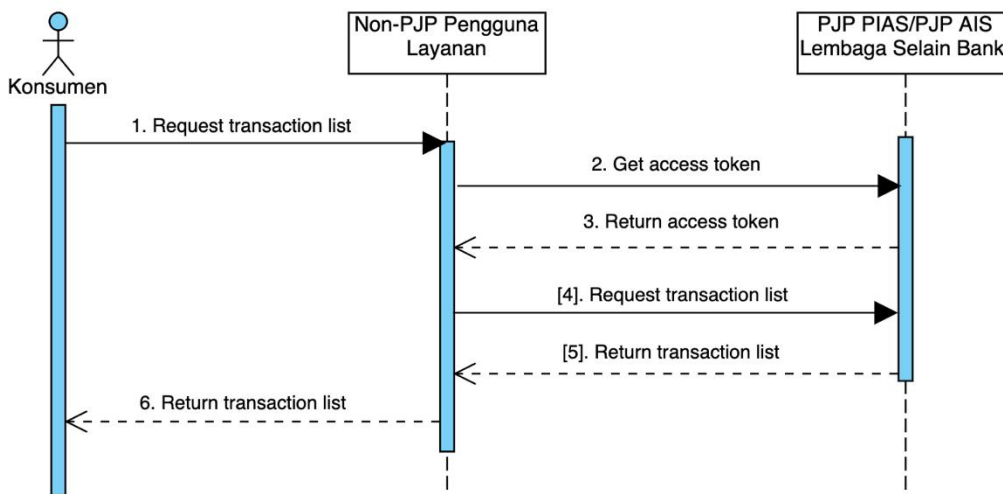

Sequence Diagram untuk API Transaction History List

#### Informasi Umum

<b>Service Code</b>	12
<b>Name</b>	API Transaction History List
<b>Version</b>	1.0
<b>HTTP Method</b>	POST
<b>Path</b>	.../{version}/transaction-history-list

#### Request Body

<b>Parameter</b>	<b>Data Type</b>	<b>Mandatory</b>	<b>Length</b>	<b>Description</b>	<b>Example</b>
partnerReferenceNo	String	O	64	Transaction identifier on service	20201029000 00000000001

<b>Parameter</b>	<b>Data Type</b>	<b>Mandatory</b>	<b>Length</b>	<b>Description</b>	<b>Example</b>
				consumer system	
fromDateTime	String	O	25	Starting time range. Default: NOW (DESC) or NOW - 1 months (ASC)  Format from date time: (ISO 8601) YYYY-MM-DDThh:mm:ss	2019-07-03T12:08:56+07:00
toDateTime	String	O	25	Ending time range. Default: NOW - 1 months (DESC) or NOW (ASC)  Format to date time: (ISO 8601) YYYY-MM-DDThh:mm:ss	2019-07-03T12:08:56+07:00
pageSize	Integer	O	2	Maximum number of transaction returned in one pagination. Default: 10	10

<b>Parameter</b>	<b>Data Type</b>	<b>Mandatory</b>	<b>Length</b>	<b>Description</b>	<b>Example</b>
pageNumber	Integer	O	2	Current page number. Default: 0	2
additionalInfo	Object	O	N/A	Additional information for custom use that are not provided by SNAP	{"deviceId": "12345679237", "channel": "mobilephone"}

### Response Body

<b>Parameter</b>	<b>Data Type</b>	<b>Mandatory</b>	<b>Length</b>	<b>Description</b>	<b>Example</b>
responseCode	String	M	7	Response code	2001200
responseMessage	String	M	150	Response description	Successful
referenceNo	String	O	64	Transaction identifier on service provider system.	202010297777 0000000009
partnerReferenceNo	String	O	64	Transaction identifier on service consumer system	202010290000 0000000001
detailData	Array				

<b>Parameter</b>	<b>Data Type</b>	<b>Mandatory</b>	<b>Length</b>	<b>Description</b>	<b>Example</b>
dateTime	String	O	25	Format datetime: (ISO 8601) YYYY-MM-DDThh:mm:ss	2019-07-03T12:08:56+07:00
amount	Object	O			
value	String	M	16,2	Net amount of the transaction. If it's IDR then value includes 2 decimal digits. e.g. IDR 10.000,- will be placed with 10000.00	12345678.00
currency	String	M	3	Currency (ISO 4217)	IDR
remark	String	O	256	Transaction remark.	Payment to Warung Ikan Bakar
sourceOfFunds	List<SourceOfFund>	O	N/A	Source of funds used for this transaction. See object definition.	{ "source": "BALANCE", "amount": { "value": "10000.00", "currency": "IDR" } }

<b>Parameter</b>	<b>Data Type</b>	<b>Mandatory</b>	<b>Length</b>	<b>Description</b>	<b>Example</b>
status	String	M	32	Transaction status. INIT, SUCCESS, CLOSED, CANCELLED	SUCCESS
type	String	M	32	Transaction type. PAYMENT, REFUND, TOP_UP, SEND_MONEY, RECEIVE_MONEY, etc	PAYMENT
additionalInfo	Object	O	N/A	Additional information for custom use from detailData	{"deviceId": "12345679237", "channel": "mobilephone"}
additionalInfo	Object	O	N/A	Additional information for custom use that are not provided by SNAP	{"deviceId": "12345679237", "channel": "mobilephone"}

### Contoh Request

```
POST .../v1.0/transaction-history-list HTTP/1.2
Content-type: application/json
Authorization: Bearer
gp9HjjEj813Y9JGoqwOeOPWbnt4CUpvIJbU1mMU4a11MNDZ7Sg5u9a"
```

Authorization-Customer: Bearer  
fa8sjjEj813Y9JGoqwOeOPWbnt4CUpvIJbU1mMU4a11MNDZ7Sg5u9a"  
X-TIMESTAMP: 2020-12-18T15:34:40+07:00  
X-SIGNATURE:  
85be817c55b2c135157c7e89f52499bf0c25ad6eebe04a986e8c86256  
1b19a5  
ORIGIN: www.hostname.com  
X-PARTNER-ID: 82150823919040624621823174737537  
X-EXTERNAL-ID: 41807553358950093184162180797837  
X-IP-ADDRESS: 172.24.281.24  
X-DEVICE-ID: 09864ADCASA  
X-LATITUDE: -6.1617169  
X-LONGITUDE: 106.6643946  
CHANNEL-ID: 95221

```
{
  "partnerReferenceNo": "202010290000000000000001",
  "fromDateTime": "2019-07-03T12:08:56+07:00",
  "toDateTime": "2019-07-03T12:08:56+07:00",
  "pageSize": "10",
  "pageNumber": "2",
  "additionalInfo": {
    "deviceId": "12345679237",
    "channel": "mobilephone"
  }
}
```

## Contoh Response

Content-type: application/json  
X-TIMESTAMP: 2020-12-18T15:34:44+07:00

```
{
  "responseCode": "2001200",
  "responseMessage": "Successful",
  "referenceNo": "202010297777000000000009",
  "partnerReferenceNo": "202010290000000000000001",
  "detailData": [
    {
      "dateTime": "2019-07-03T12:08:56+07:00",
      "amount": {
        "value": "12345678.00",
        "currency": "IDR"
      },
      "remark": "Payment to Warung Ikan Bakar",
      "sourceOfFunds": [
        {
          "source": "BALANCE",
          "amount": {
            "value": "10000.00",
            "currency": "IDR"
          }
        }
      ]
    }
  ]
}
```

```
        }
      }
    ],
    "status": "SUCCESS",
    "type": "PAYMENT",
    "additionalInfo": {
      "deviceId": "12345679237",
      "channel": "mobilephone"
    }
  }
],
"additionalInfo": {
  "deviceId": "12345679237",
  "channel": "mobilephone"
}
}
```

### 3.2.2. API Transaction History Detail

#### Ketentuan dan Keterbatasan API

<b>Riwayat Transaksi Tertua</b>	1 tahun
---------------------------------	---------

#### Sequence Diagram

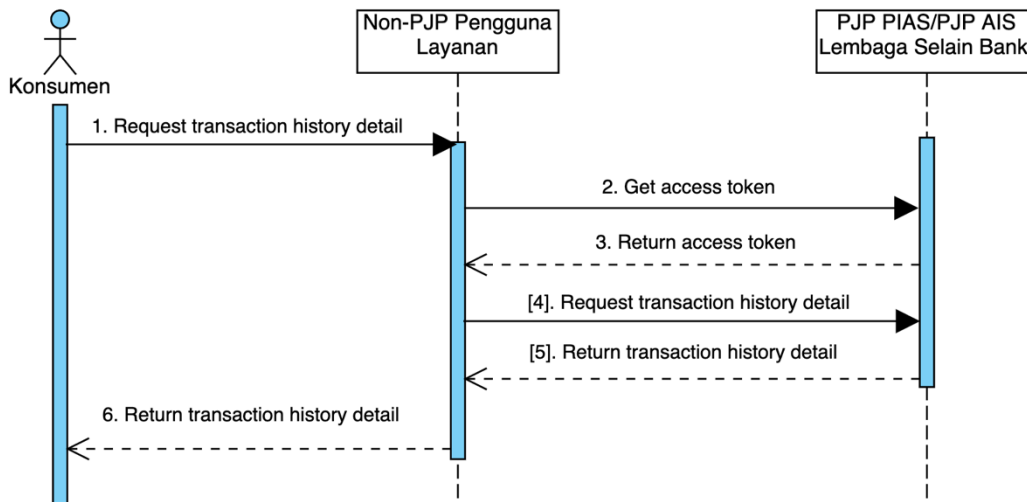

Sequence Diagram untuk API Transaction History Detail

#### Informasi Umum

<b>Service Code</b>	13
<b>Name</b>	API Transaction History Detail
<b>Version</b>	1.0
<b>HTTP Method</b>	POST
<b>Path</b>	.../{version}/transaction-history-detail

#### Request Body

<i>Parameter</i>	<i>Data Type</i>	<i>Mandatory</i>	<i>Length</i>	<i>Description</i>	<i>Example</i>
originalPartnerReferenceNo	String	M	64	Transaction identifier on service consumer system	20201029000 00000000001



<b>Parameter</b>	<b>Data Type</b>	<b>Mandatory</b>	<b>Length</b>	<b>Description</b>	<b>Example</b>
additionalInfo	Object	O	N/A	Additional information for custom use that are not provided by SNAP	{ "deviceId": "12345679237", "channel": "mobilephone"}

### Response Body

<b>Parameter</b>	<b>Data Type</b>	<b>Mandatory</b>	<b>Length</b>	<b>Description</b>	<b>Example</b>
responseCode	String	M	7	Response code	2001300
responseMessage	String	M	150	Response description	Successful
referenceNo	String	C	64	Transaction identifier on service provider system.  Must be filled upon successful transaction	2020102977 7700000000 09
partnerReferenceNo	String	O	64	Transaction identifier on service consumer system	2020102900 0000000000 01
amount	Object	O			

<b>Parameter</b>	<b>Data Type</b>	<b>Mandatory</b>	<b>Length</b>	<b>Description</b>	<b>Example</b>
value	String	M	16,2	Net amount of the transaction. If it's IDR then value includes 2 decimal digits. e.g. IDR 10.000,- will be placed with 10000.00	12345678.00
currency	String	M	3	Currency (ISO 4217)	IDR
cancelledTime	String	O	25	Transaction cancelled time.  Format cancelled date : (ISO 8601) YYYY-MM-DDThh:mm:ss	2009-07-03T12:08:56+07:00
dateTime	String	M	25	Transaction created time.  Format date time : (ISO 8601) YYYY-MM-DDThh:mm:ss	2009-07-03T12:08:56+07:00
refundAmount	Object	O			

<b>Parameter</b>	<b>Data Type</b>	<b>Mandatory</b>	<b>Length</b>	<b>Description</b>	<b>Example</b>
value	<i>String</i>	M	16,2	Refund amount of the transaction. If it's IDR then value includes 2 decimal digits. e.g. IDR 10.000,- will be placed with 10000.00	12345678.00
currency	<i>String</i>	M	3	Currency (ISO 4217)	IDR
remark	<i>String</i>	O	256	Transaction remark.	Payment to Warung Ikan Bakar
sourceOfFunds	<i>List&lt;SourceOfFund&gt;</i>	O	N/A	Source of funds used for this transaction.  See object definition.	{{"source": "BALANCE", "amount": {"value": "10000.00", "currency": "IDR"}}}
status	<i>String</i>	M	32	Transaction status: <b>INIT,</b> <b>SUCCESS,</b> <b>CLOSED,</b> <b>CANCELLED</b>	SUCCESS
type	<i>String</i>	M	32	Transaction type:	PAYMENT

<b>Parameter</b>	<b>Data Type</b>	<b>Mandatory</b>	<b>Length</b>	<b>Description</b>	<b>Example</b>
				<b>PAYMENT, REFUND, TOP_UP, SEND_MONEY, RECEIVE_MONEY, etc.</b>	
additionalInfo	Object	O	N/A	Additional information for custom use that are not provided by SNAP	{"deviceId": "12345679237", "channel": "mobilephone"}

### Contoh Request

```

POST .../v1.0/transaction-history-detail HTTP/1.2
Content-type: application/json
Authorization: Bearer
gp9HjjEj813Y9JGoqwOeOPWbnt4CUpvIJbU1mMU4a11MNDZ7Sg5u9a"
Authorization-Customer: Bearer
fa8sjjEj813Y9JGoqwOeOPWbnt4CUpvIJbU1mMU4a11MNDZ7Sg5u9a"
X-TIMESTAMP: 2020-12-18T15:55:40+07:00
X-SIGNATURE:
85be817c55b2c135157c7e89f52499bf0c25ad6eeeb04a986e8c86256
1b19a5
ORIGIN: www.hostname.com
X-PARTNER-ID: 82150823919040624621823174737537
X-EXTERNAL-ID: 41807553358950093184162180797837
X-IP-ADDRESS: 172.24.281.24
X-DEVICE-ID: 09864ADCASA
X-LATITUDE: -6.1617169
X-LONGITUDE: 106.6643946CHANNEL-ID: 95221

{
  "originalPartnerReferenceNo": "20201029000000000001",
  "additionalInfo": {
    "deviceId": "12345679237",
    "channel": "mobilephone"
  }
}

```

## Contoh Response

Content-type: application/json

X-TIMESTAMP: 2020-12-18T15:55:47+07:00

```
{
  "responseCode":"2001300",
  "responseMessage":"Successful",
  "referenceNo":"20201029777700000000009",
  "partnerReferenceNo":"20201029000000000000001",
  "amount":{
    "value":"12345678.00",
    "currency":"IDR"
  },
  "cancelledTime":"2009-07-03T12:08:56+07:00",
  "dateTime":"2009-07-03T12:08:56+07:00",
  "refundAmount":{
    "value":"12345678.00",
    "currency":"IDR"
  },
  "remark":"Payment to Warung Ikan Bakar",
  "sourceOfFunds":[
    {
      "source":"BALANCE",
      "amount":{
        "value":"10000.00",
        "currency":"IDR"
      }
    }
  ],
  "status":"SUCCESS",
  "type":"PAYMENT",
  "additionalInfo":{
    "deviceId":"12345679237",
    "channel":"mobilephone"
  }
}
```

### 3.2.3. API Bank Statement

#### Ketentuan dan Keterbatasan API

<b>Pengurutan</b>	DESC
<b>Rentang Waktu Maksimal</b>	1 bulan
<b>Riwayat Transaksi Tertua</b>	1 tahun

#### Sequence Diagram

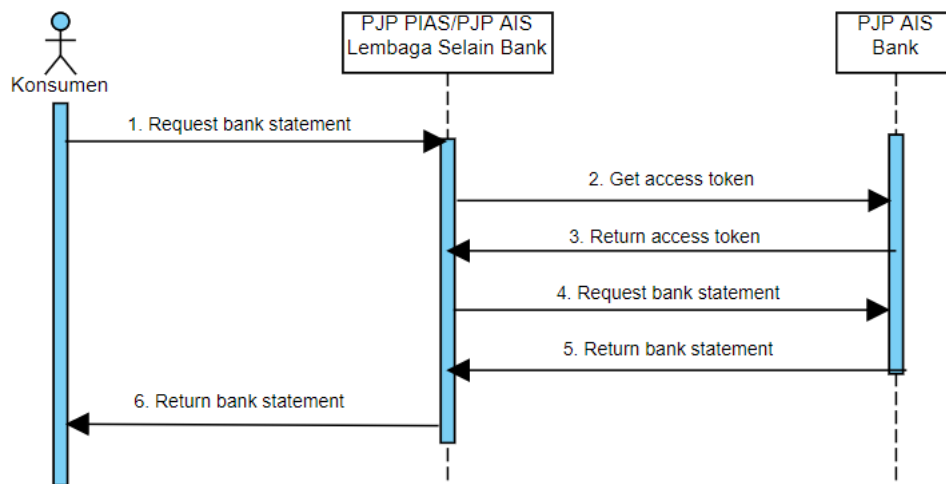

Sequence Diagram untuk API Bank Statement

#### Informasi Umum

<b>Service Code</b>	14
<b>Name</b>	API Bank Statement
<b>Version</b>	1.0
<b>HTTP Method</b>	POST
<b>Path</b>	.../{version}/bank-statement

#### Request Body

<i>Parameter</i>	<i>Data Type</i>	<i>Mandatory</i>	<i>Length</i>	<i>Description</i>	<i>Example</i>
partnerReferenceNo	String	O	64	Transaction identifier on service	2020102900 0000000000 01

<b>Parameter</b>	<b>Data Type</b>	<b>Mandatory</b>	<b>Length</b>	<b>Description</b>	<b>Example</b>
				consumer system	
bankCardToken	String	C	128	Card token for payment. Must be filled if accountNo is null	6d796361726 4746f6b656e
accountNo	String	C	16	Bank account number. Must be filled if bankCardToken is null	7382382957 893840
fromDateTime	String	O	25	Starting time range. Default: NOW (DESC) or NOW – 1 months (ASC)  Format from date time : (ISO 8601) YYYY-MM-DDThh:mm:ss	2019-07-03T12:08:56+07:00
toDateTime	String	O	25	Ending time range. Default:	2019-07-03T12:08:56+07:00

<b>Parameter</b>	<b>Data Type</b>	<b>Mandatory</b>	<b>Length</b>	<b>Description</b>	<b>Example</b>
				NOW – 1 months (DESC) or NOW (ASC)  Format to date time: (ISO 8601) YYYY-MM-DDThh:mm:ss	
additionalInfo	Object	O	N/A	Additional information for custom use that are not provided by SNAP	{"deviceId": "12345679237", "channel": "mobilephone"}

### Response Body

<b>Parameter</b>	<b>Data Type</b>	<b>Mandatory</b>	<b>Length</b>	<b>Description</b>	<b>Example</b>
responseCode	String	M	7	Response code	2001400
responseMessage	String	M	150	Response description	Successful
referenceNo	String	C	64	Transaction identifier on service provider system. Must be filled upon	2020102977 7700000000 09



<b>Parameter</b>	<b>Data Type</b>	<b>Mandatory</b>	<b>Length</b>	<b>Description</b>	<b>Example</b>
				successful transaction	
partnerReferenceNo	String	O	64	Transaction identifier on service consumer system	2020102900 0000000000 01
balance	Array of Objects	O	N/A	Starting and ending balance before the first/last transaction.	[{"amount": {"value": "10000.00", "currency": "IDR"}, "dateTime": "2020-12-18T16:03:45+07:00"}]
amount	Object	M			
value	String	M	16,2	Transaction Amount. Nominal inputted by Customer with 2 decimal	10000.00
currency	String	M	3	Currency (ISO 4217)	IDR
dateTime	String	M	25	Format date time: (ISO 8601) YYYY-MM-DDThh:mm:ss	2020-12-18T16:03:45+07:00
startingBalance	Object	M			

<b>Parameter</b>	<b>Data Type</b>	<b>Mandatory</b>	<b>Length</b>	<b>Description</b>	<b>Example</b>
value	String	M	16,2	Transaction Amount. Nominal inputted by Customer with 2 decimal	12345678.00
currency	String	M	3	Currency (ISO4217)	IDR
dateTime	String	M	25	Format date time : (ISO 8601) YYYY-MM-DDThh:mm:ss	2020-12-18T16:03:45+07:00
endingBalance	Object	M			
value	String	M	16,2	Transaction Amount. Nominal inputted by Customer with 2 decimal	12345678.00
currency	String	M	3	Currency (ISO4217)	IDR
dateTime	String	M	25	Format date time : (ISO 8601) YYYY-MM-DDThh:mm:ss	2020-12-19T16:03:45+07:00
totalCreditEntries	DebitAndCreditEntries	O	N/A	Total transaction amount with	{"numberOfEntries": "10", "amount": {

<b>Parameter</b>	<b>Data Type</b>	<b>Mandatory</b>	<b>Length</b>	<b>Description</b>	<b>Example</b>
				type = <b>CREDIT</b> . See object definition	"value": "10000.00", "currency": "IDR"}}
totalDebitEntries	DebitAndCreditEntries	O	N/A	Total transaction amount with type = <b>DEBIT</b> . See object definition	{"numberOfEntries": "10", "amount": { "value": "10000.00", "currency": "IDR"}}
hasMore	String	O	1	Memberikan informasi apakah masih ada record yang belum ditampilkan dalam rentang fromDateTime toDateTime  <b>Y</b> = Yes <b>N</b> = No.	Y
lastRecordDate Time	String	O	25	Format last record date time: (ISO 8601) YYYY-MM-DDThh:mm:ss	2021-11- 24T11:54:56 +07:00
detailData	Array of Objects				
detailBalance	Object	O	N/A	Starting and ending	

<b>Parameter</b>	<b>Data Type</b>	<b>Mandatory</b>	<b>Length</b>	<b>Description</b>	<b>Example</b>
				balance before and after transaction.	
startAmount	Array of Objects	O			[{"amount": {"value": "10000.00", "currency": "IDR"}}]
endAmount	Array of Objects	O			[{"amount": {"value": "10000.00", "currency": "IDR"}}]
amount	Object	O			
value	String	M	16,2	Net amount of the transaction. If it's IDR then value includes 2 decimal digits. e.g. IDR 10.000,- will be placed with 10000.00	12345678.00
currency	String	M	3	Currency (ISO 4217)	IDR

<b>Parameter</b>	<b>Data Type</b>	<b>Mandatory</b>	<b>Length</b>	<b>Description</b>	<b>Example</b>
originAmount	Object	O			
value	String	M	16,2	Origin net amount of the transaction. If it's IDR then value includes 2 decimal digits. e.g. IDR 10.000,- will be placed with 10000.00	12345678.00
currency	String	M	3	Currency (ISO 4217)	IDR
transactionDate	String	M	25	Timestamp of the Transaction.  Format transaction date : (ISO 8601) YYYY-MM-DDThh:mm:ss	2009-07-03T12:08:56+07:00
remark	String	M	256	Transaction remark.	Payment to Warung Ikan Bakar
transactionId	String	O	35	Internal transaction identifier from	2020080119 8230912830 091123

<b>Parameter</b>	<b>Data Type</b>	<b>Mandatory</b>	<b>Length</b>	<b>Description</b>	<b>Example</b>
				publisher perspective.	
type	String	M	6	Transaction type. <b>CREDIT / DEBIT</b>	CREDIT
transactionDetail Status	String	O	20	Transaction detail indicator (original transaction or error correction) <b>SUCCESS / ERROR CORECTION</b>	SUCCESS
detailInfo	Object	O		Additional information of detail transaction	"page": "12"
additionalInfo	Object	O	N/A	Additional information for custom use that are not provided by SNAP	{"deviceId": "12345679237", "channel": "mobilephone"}

### Contoh Request

```
POST .../v1.0/bank-statement HTTP/1.2
Content-type: application/json
Authorization: Bearer
gp9HjjEj813Y9JGoqwOeOPWbnt4CUpvIJbU1mMU4a11MNDZ7Sg5u9a"
```

```

Authorization-Customer: Bearer
fa8sjjEj813Y9JGoqwOeOPWbnt4CUpvIJbU1mMU4a11MNDZ7Sg5u9a"
X-TIMESTAMP: 2020-12-18T16:03:40+07:00
X-SIGNATURE:
85be817c55b2c135157c7e89f52499bf0c25ad6eebe04a986e8c86256
1b19a5
ORIGIN: www.hostname.com
X-PARTNER-ID: 82150823919040624621823174737537
X-EXTERNAL-ID: 41807553358950093184162180797837
X-IP-ADDRESS: 172.24.281.24
X-DEVICE-ID: 09864ADCASA
X-LATITUDE: -6.1617169
X-LONGITUDE: 106.6643946
CHANNEL-ID: 95221
{
  "partnerReferenceNo":"202010290000000000000001",
  "bankCardToken":"6d7963617264746f6b656e",
  "accountNo":"7382382957893840",
  "fromDateTime":"2019-07-03T12:08:56+07:00",
  "toDateTime":"2019-07-03T12:08:56+07:00",
  "additionalInfo":{
    "deviceId":"12345679237",
    "channel":"mobilephone"
  }
}

```

### Contoh Response

```

Content-type: application/json
X-TIMESTAMP: 2020-12-18T16:03:45+07:00
{
  "responseCode":"2001400",
  "responseMessage":"Successful",
  "referenceNo":"202010297777000000000009",
  "partnerReferenceNo":"202010290000000000000001",
  "balance":[
    {
      "amount":{
        "value":"10000.00",
        "currency":"IDR",
        "dateTime":"2020-12-18T16:03:45+07:00"
      },
      "startingBalance":{
        "value":"12345678.00",
        "currency":"IDR",
        "dateTime":"2020-12-18T16:03:45+07:00"
      },
      "endingBalance":{
        "value":"12345678.00",
        "currency":"IDR",
        "dateTime":"2020-12-19T16:03:45+07:00"
      }
    }
  ]
}

```

```

    }
  }
],
"totalCreditEntries":{
  "numberOfEntries":"10",
  "amount":{
    "value":"10000.00",
    "currency":"IDR"
  }
},
"totalDebitEntries":{
  "numberOfEntries":"10",
  "amount":{
    "value":"10000.00",
    "currency":"IDR"
  }
},
"hasMore":"Y",
"lastRecordDateTime":"2021-11-24T11:54:56+07:00",
"detailData":[
  {
    "detailBalance":{
      "startAmount":[
        {
          "amount":{
            "value":"10000.00",
            "currency":"IDR"
          }
        }
      ],
      "endAmount":[
        {
          "amount":{
            "value":"10000.00",
            "currency":"IDR"
          }
        }
      ]
    },
    "amount":{
      "value":"12345678.00",
      "currency":"IDR"
    },
    "originAmount":{
      "value":"12345678.00",
      "currency":"IDR"
    },
    "transactionDate":"2009-07-03T12:08:56+07:00",
    "remark":"Payment to Warung Ikan Bakar",
    "transactionId":"20200801198230912830091123",
    "type":"CREDIT",
  }
]

```



```

        "transactionDetailStatus": "SUCCESS",
        "detailInfo": {
            "page": "12"
        }
    },
    ],
    "additionalInfo": {
        "deviceId": "12345679237",
        "channel": "mobilephone"
    }
}

```

## Definisi Tipe

### ResultInfo

<b>Parameter</b>	<b>Data Type</b>	<b>Mandatory</b>	<b>Length</b>	<b>Description</b>	<b>Example</b>
<i>resultCodeId</i>	<i>String</i>	<i>M</i>	8	<i>Result code unique identifier.</i>	<i>00000000</i>
<i>resultCode</i>	<i>String</i>	<i>M</i>	64	<i>Result code.</i>	<i>SUCCESS</i>
<i>resultStatus</i>	<i>String</i>	<i>M</i>	1	<i>Result status. S/F/U</i>	<i>S</i>
<i>resultMsg</i>	<i>String</i>	<i>O</i>	256	<i>Result message, can be filled with the reason of error.</i>	<i>Successfully processed.</i>

### SourceOfFund

<b>Parameter</b>	<b>Data Type</b>	<b>Mandatory</b>	<b>Length</b>	<b>Description</b>	<b>Example</b>
<i>source</i>	<i>String</i>	<i>M</i>	32	<i>Source of fund. BALANCE/et c.</i>	<i>BALANCE</i>
<i>amount</i>	<i>Object</i>	<i>O</i>			
<i>value</i>	<i>String</i>	<i>M</i>	16,2	<i>Net amount of the transaction. If it's IDR then value includes 2</i>	<i>12345678.00</i>

<b>Parameter</b>	<b>Data Type</b>	<b>Mandatory</b>	<b>Length</b>	<b>Description</b>	<b>Example</b>
				<i>decimal digits. e.g. IDR 10.000,- will be placed with 10000.00</i>	
currency	String	M	3	Currency (ISO 4217)	IDR

### CashBalance

<b>Parameter</b>	<b>Data Type</b>	<b>Mandatory</b>	<b>Length</b>	<b>Description</b>	<b>Example</b>
amount	Object	O			
value	String	M	16,2	<i>Amount of balance. If it's IDR then value includes 2 decimal digits. e.g. IDR 10.000,- will be placed with 10000.00</i>	12345678.00
currency	String	M	3	Currency (ISO 4217)	IDR
date	ISODateTime	M	25	<i>Timestamp of the balance. format date: (ISO 8601) YYYY-MM-DDThh:mm:ss</i>	2009-07-03T12:08:56+07:00

### DetailBalance

<b>Parameter</b>	<b>Data Type</b>	<b>Mandatory</b>	<b>Length</b>	<b>Description</b>	<b>Example</b>
amount	Object	O			
value	String	M	16,2	<i>Amount of balance. If it's IDR then value includes 2 decimal digits.</i>	12345678.00

<b>Parameter</b>	<b>Data Type</b>	<b>Mandatory</b>	<b>Length</b>	<b>Description</b>	<b>Example</b>
				<i>e.g. IDR 10.000,- will be placed with 10000.00</i>	
currency	String	M	3	Currency (ISO 4217)	IDR

### **ActiveCurrencyAndAmount**

<b>Parameter</b>	<b>Data Type</b>	<b>Mandatory</b>	<b>Length</b>	<b>Description</b>	<b>Example</b>
<i>value</i>	String	M	18	<i>Value of the amount. If it's IDR then value includes 2 decimal digits. e.g. IDR 10.000,- will be placed with 10000.00</i>	10000.00
currency	String	M	3	Currency. ISO-4217	IDR

## DebitAndCreditEntries

<b>Parameter</b>	<b>Data Type</b>	<b>Mandatory</b>	<b>Length</b>	<b>Description</b>	<b>Example</b>
<i>numberOfEntries</i>	<i>int</i>	<i>0</i>	<i>5</i>	<i>Number of entries</i>	<i>10</i>
<i>amount</i>	<i>Object</i>				
<i>value</i>	<i>String</i>	<i>M</i>	<i>18</i>	<i>Value of the amount. If it's IDR then value includes 2 decimal digits. e.g. IDR 10.000,- will be placed with 10000.00</i>	<i>10000.00</i>
<i>currency</i>	<i>String</i>	<i>M</i>	<i>3</i>	<i>Currency. ISO-4217</i>	<i>IDR</i>

#### 4. KATEGORI IV: TRANSFER KREDIT

API Transfer Kredit digunakan untuk melakukan pemindahbukuan dana dari satu rekening ke rekening lain baik dalam PJP AIS yang sama maupun PJP AIS yang berbeda yang diinisiasi oleh pihak pengirim (pihak terdebit).

##### 4.1. SKENARIO PENGGUNAAN API TRANSFER KREDIT

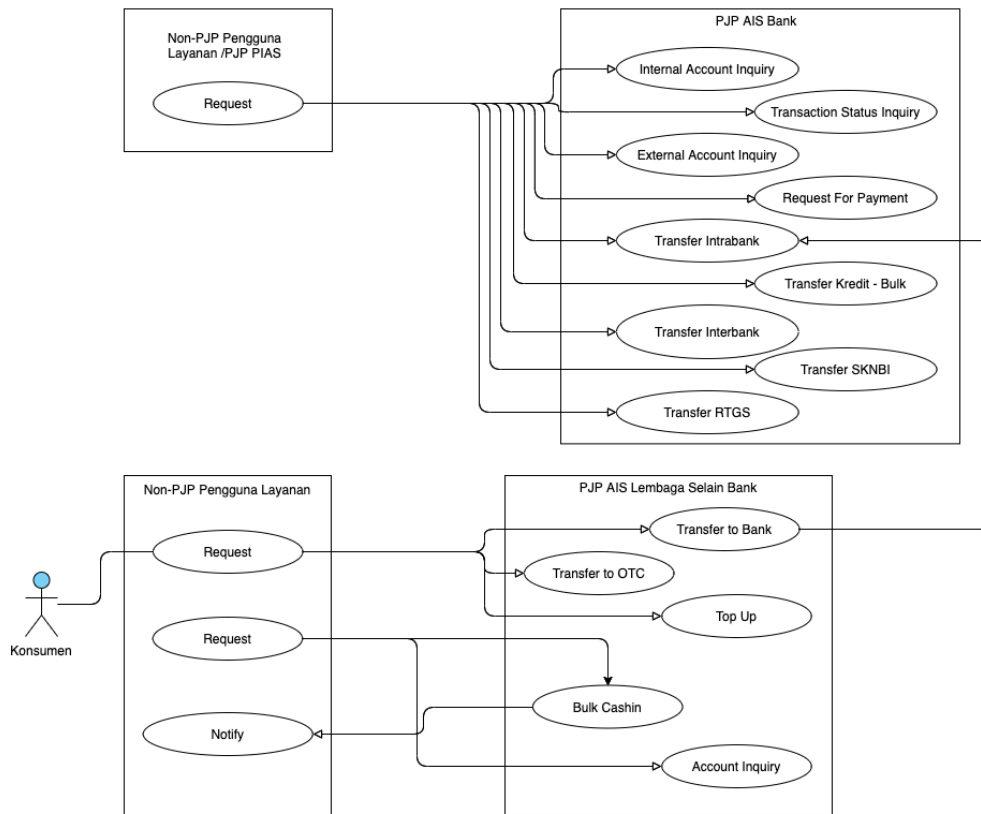

*Use Case Diagram API Transfer Credit*

Merujuk pada *use case diagram*, pemilik rekening yaitu Non-PJP Pengguna Layanan, atau PJP PIAS dapat melakukan pemindahanbukuan dana atas rekeningnya menggunakan:

- API internal account inquiry, external account inquiry, intrabank transfer, interbank transfer, transfer RTGS, transfer SKNBI, dan transaction status inquiry yang disediakan oleh PJP AIS Bank; dan
- API inquiry transaction, customer top up, bulk cashin, transfer to bank, transfer to OTC, CPM, MPM, transaction status inquiry, auth payment yang disediakan oleh PJP AIS Lembaga Selain Bank.

Pemilik rekening yaitu Konsumen, dapat melakukan pemindahanbukuan dana atas rekeningnya menggunakan:

- API Transfer to Bank, API Transfer to OTC, CPM, dan MPM yang disediakan oleh PJP AIS Lembaga Selain Bank.

API Transfer Kredit dapat digunakan dalam sejumlah skema sebagai berikut:

**Skema 1: Non-PJP Pengguna Layanan / PJP PIAS / PJP AIS Lembaga Selain Bank – PJP AIS Bank**

Dalam skema ini, Non-PJP Pengguna Layanan, PJP PIAS, atau PJP AIS Lembaga Selain Bank dapat melakukan pemindabukuan dana yang bersumber dari rekeningnya (skema B2B) melalui layanan transfer kredit pada PJP AIS Bank menggunakan API intrabank transfer, interbank transfer, request for payment, interbank transfer (bulk), transfer RTGS, dan transfer SKNBI.

Dalam skema ini, Non-PJP Pengguna Layanan dapat terhubung langsung ke PJP AIS maupun melalui PJP PIAS/PJP AIS Lembaga Selain Bank.

- Intrabank transfer:  
API Intrabank Transfer digunakan untuk melakukan pemindahbukuan dana dari rekening Non-PJP Pengguna Layanan, PJP PIAS, atau PJP AIS Lembaga Selain Bank ke rekening tujuan pada satu PJP AIS Bank.
- Interbank Transfer:  
API Interbank Transfer digunakan untuk melakukan pemindahbukuan dana dari satu rekening Non-PJP Pengguna Layanan, PJP PIAS, atau PJP AIS Lembaga Selain Bank, pada PJP AIS Bank ke rekening tujuan pada PJP AIS Bank lain melalui perantaraan Penyelenggara Infrastruktur Pembayaran (PIP) seperti GPN atau BI-FAST.
- Request for Payment:  
API Request for Payment digunakan untuk melakukan penagihan oleh Non-PJP Pengguna Layanan, PJP PIAS, atau PJP AIS Lembaga Selain Bank. Apabila pihak tertagih menyetujui tagihan, proses pembayaran tagihan dilakukan menggunakan API Intrabank atau API Interbank.

- **Interbank Transfer - Bulk:**  
API Interbank Transfer - Bulk digunakan untuk melakukan pemindahbukuan dana dari 1 (satu) rekening dengan tujuan lebih dari 1 (satu) rekening pada 1 (satu) atau lebih bank. Proses transaksi ini dapat diinisiasi oleh Non-PJP Pengguna Layanan atau PJP PIAS, dalam bentuk instruksi *bulk*. Transaksi kemudian diteruskan oleh PJP AIS Bank pengirim ke BI-FAST untuk dilakukan *de-bulking* dan diteruskan ke PJP AIS Bank penerima dalam bentuk instruksi individual.
- **Transfer RTGS:**  
API Transfer RTGS digunakan untuk melakukan pemindahbukuan dana dari satu rekening Non-PJP Pengguna Layanan, PJP PIAS, atau PJP AIS Lembaga Selain Bank, pada PJP AIS Bank ke rekening tujuan pada PJP AIS Bank lain melalui perantaraan Penyelenggara Infrastruktur Pembayaran (PIP) BI-RTGS.
- **Transfer SKNBI:**  
API Transfer SKNBI digunakan untuk melakukan pemindahbukuan dana dari satu rekening Non-PJP Pengguna Layanan, PJP PIAS, atau PJP AIS Lembaga Selain Bank, pada PJP AIS Bank ke rekening tujuan pada PJP AIS Bank lain melalui perantaraan Penyelenggara Infrastruktur Pembayaran (PIP) SKNBI.
- **Transfer *Virtual Account*:**  
Pembayaran menggunakan *virtual account* pada dasarnya adalah melakukan transfer ke suatu nomor rekening yang bersifat *virtual* dan ketika dilakukan pemindahbukuan ke dalam nomor rekening tersebut, akan langsung masuk ke nomor rekening asli yang terhubung ke *virtual account* tersebut. Dengan memanfaatkan *virtual account*, Pengguna Layanan dapat mengidentifikasi tujuan pembayaran dari setiap transfer yang diterima. Informasi pembayaran beserta nomor *virtual account* akan tercantum pada mutasi di rekening koran Pengguna Layanan.

Skenario penggunaan *virtual account* terbagi menjadi:

❖ *Create VA*

Pada skenario ini, nomor *virtual account* dikelola oleh Penyedia Layanan. Permintaan pembuatan nomor *virtual account* dilakukan oleh Non-PJP Pengguna Layanan kepada Penyedia Layanan melalui API.

❖ *Inquiry payment*

Pada skenario ini, nomor *virtual account* dikelola oleh Non-PJP Pengguna Layanan. Setiap kali terdapat pembayaran maka Penyedia Layanan akan melakukan inquiry ke Non-PJP Pengguna Layanan untuk mendapatkan detail dari pembayaran/tagihan. Penyedia Layanan memberikan notifikasi secara *realtime* kepada Non-PJP Pengguna Layanan melalui API setiap kali terjadi pembayaran.

❖ *Fund Transfer to VA*

Pada skenario ini, Pengguna Layanan bekerja sama dengan Penyedia Layanan untuk menjadi antarmuka proses pembayaran *virtual account* dari Pengguna Layanan lainnya.

Nomor *virtual account* dapat dihasilkan untuk menerima satu pembayaran maupun digunakan secara berulang. Pembayaran menggunakan *virtual account* dimungkinkan juga untuk dilakukan antar PJP melalui infrastruktur pembayaran (GPN atau BI-FAST).

Sebelum melakukan pemindahbukuan Intrabank, dilakukan validasi nomor dan nama rekening tujuan menggunakan API Internal Account Inquiry.

Sebelum melakukan pemindahbukuan Interbank, RTGS, atau SKNBI, dilakukan validasi nomor dan nama rekening tujuan menggunakan API External Account Inquiry.

Apabila terjadi gangguan pada sistem, time out, atau hal-hal lain yang dapat menyebabkan perbedaan interpretasi atas penyelesaian suatu transaksi, maka pihak yang menginisiasi transaksi (Non-PJP Pengguna Layanan, PJP PIAS, atau PJP AIS Lembaga Selain Bank) dapat mengakses API Transaction Status Inquiry yang disediakan oleh PJP AIS Bank.



### **Skema 2: Non-PJP Pengguna Layanan – PJP AIS Lembaga Selain Bank**

Dalam skema ini, Non-PJP Pengguna Layanan dapat melakukan pemindahbukuan atas dana pada rekeningnya kepada rekening Konsumen melalui layanan transfer kredit pada PJP AIS Lembaga Selain Bank menggunakan API bulk cashin. PJP AIS Lembaga Selain Bank menginformasikan status transaksi bulk cashin ke Non-PJP Pengguna Layanan menggunakan API *notify bulk*.

### **Skema 3: Konsumen - Non-PJP Pengguna Layanan/PJP PIAS – PJP AIS**

Dalam skema ini, konsumen dapat melakukan top up saldo uang elektronik, transfer to OTC, dan transfer to bank, pada PJP AIS melalui Non-PJP Pengguna Layanan menggunakan API Customer Top Up, Transfer to OTC, dan Transfer to Bank.

- Top up saldo uang elektronik  
API customer top up digunakan untuk pemindahbukuan dana dari rekening Non-PJP Pengguna Layanan ke rekening konsumen. Sebelum pemindahbukuan, Non-PJP Pengguna Layanan melakukan validasi rekening konsumen menggunakan API Account Inquiry.
- Transfer to OTC  
API Transfer to OTC digunakan untuk pemindahbukuan dana dari rekening Konsumen ke rekening Non-PJP Pengguna Layanan. Sebelum pemindahbukuan, Konsumen melakukan inisiasi transaksi OTC untuk mendapatkan token dari PJP AIS pengelola rekeningnya.
- Transfer to bank  
API Transfer to bank digunakan untuk pemindahbukuan dari rekening konsumen pada PJP AIS Lembaga Selain Bank ke rekening konsumen pada PJP AIS Bank, yang diinisiasi oleh konsumen melalui Non-PJP Pengguna Layanan. Sebelum pemindahbukuan, Non-PJP Pengguna Layanan melakukan validasi akun konsumen menggunakan API inquiry transaction.

Apabila terjadi gangguan pada sistem, time out, atau hal-hal lain yang dapat menyebabkan perbedaan interpretasi atas penyelesaian suatu transaksi, maka

pihak yang menginisiasi transaksi (Non-PJP Pengguna Layanan, atau PJP PIAS) dapat mengakses API transaction status inquiry yang disediakan oleh PJP AIS.

**Skema 4: QR MPM (Konsumen – Non-PJP Pengguna Layanan – PJP PIAS – PIP (Switching) – PJP AIS)**

Skema ini merupakan transaksi sesuai standar MPM. Konsumen dapat melakukan pembayaran kepada Non-PJP Pengguna Layanan menggunakan dana yang berasal dari rekening konsumen pada PJP AIS Bank atau PJP AIS Lembaga Selain Bank, menggunakan API MPM Payment.

Transaksi pembayaran ini dilakukan menggunakan QR yang dihasilkan dari API Generate QR dengan alternatif sebagai berikut:

- Pada mode redirection, konsumen akan diarahkan ke halaman web checkout Non-PJP Pengguna Layanan. PJP PIAS meminta PJP AIS Bank atau PJP AIS Lembaga Selain Bank untuk melakukan decode QR menggunakan API Decode QR. PJP PIAS melakukan request OTT untuk mendapatkan otorisasi menggunakan API Apply OTT, selanjutnya OTT disertakan pada redirect URL.
- Pada mode statis, konsumen diarahkan pada halaman web PJP AIS untuk memasukkan nominal.

Apabila terjadi kesalahan dalam transaksi, konsumen dapat melakukan pembatalan menggunakan API Cancel Payment.

Apabila terjadi gangguan pada sistem, time out, atau hal-hal lain yang dapat menyebabkan perbedaan interpretasi atas penyelesaian suatu transaksi, maka:

- Pihak yang menginisiasi transaksi mengkonfirmasi status transaksi dengan mengakses API Query Payment yang disediakan oleh PJP AIS.
- Pihak yang menyelesaikan transaksi (PJP AIS) menyampaikan status transaksi menggunakan API Payment Notify.

## 4.2. SPESIFIKASI API TRANSFER KREDIT BANK

### 4.2.1. API Account Inquiry

#### 4.2.1.1. Internal Account Inquiry

##### Sequence Diagram

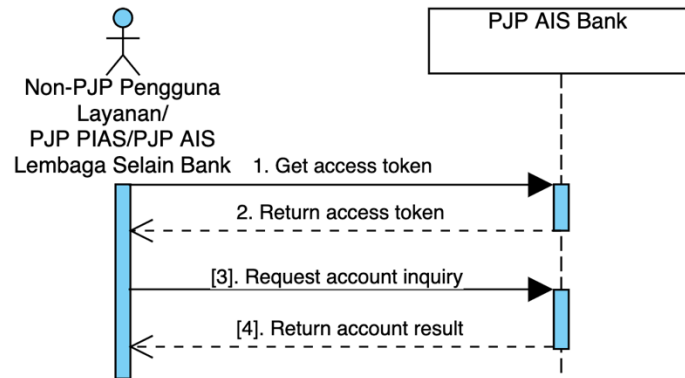

Sequence Diagram API Internal Account Inquiry

##### Informasi Umum

<b>Service Code</b>	15
<b>Name</b>	API Internal Account Inquiry
<b>Version</b>	1.0
<b>HTTP Method</b>	POST
<b>Path</b>	.../{version}/account-inquiry-internal

##### Request Body

<b>Parameter</b>	<b>Data Type</b>	<b>Mandatory</b>	<b>Length</b>	<b>Description</b>	<b>Example</b>
partnerReferenceNo	String	O	64	Transaction identifier on service consumer system	20201029000000000001
beneficiaryAccountNo	String	M	34	Beneficiary Account Number	888801000157508
additionalInfo	Object	O	N/A	Additional information for	{"deviceId": "12345679237",

<b>Parameter</b>	<b>Data Type</b>	<b>Mandatory</b>	<b>Length</b>	<b>Description</b>	<b>Example</b>
				custom use that are not provided by SNAP	"channel": "mobilephone";}

### Response Body

<b>Parameter</b>	<b>Data Type</b>	<b>Mandatory</b>	<b>Length</b>	<b>Description</b>	<b>Example</b>
responseCode	String	M	7	Response code	2001500
responseMessage	String	M	150	Response description	Successful
referenceNo	String	O	64	Transaction identifier on service provider system.	2020102977 7700000000 09
partnerReferenceNo	String	O	64	Transaction identifier on service consumer system	2020102900 0000000000 01
beneficiaryAccountName	String	M	100	Beneficiary Account Name	Yories Yolanda
beneficiaryAccountNo	String	M	34	Beneficiary Account Number	8888010001 57508
beneficiaryAccountStatus	String	O	16	Beneficiary Account	Rekening aktif

<b>Parameter</b>	<b>Data Type</b>	<b>Mandatory</b>	<b>Length</b>	<b>Description</b>	<b>Example</b>
				Status	
beneficiaryAccountType	String	O	1	Beneficiary Account Type <b>D</b> = Current Account <b>S</b> = Saving Account	D
currency	String	O	3	Currency Type	IDR
additionalInfo	Object	O	N/A	Additional information for custom use that are not provided by SNAP	{"deviceId": "12345679237", "channel": "mobilephone",}

### Contoh Request

```

POST .../v1.0/account-inquiry-internal HTTP/1.2
Content-type: application/json
Authorization: Bearer
gp9HjjEj813Y9JGoqwOeOPWbnt4CUpvIJbU1mMU4a11MNDZ7Sg5u9a"
Authorization-Customer: Bearer
fa8sjjEj813Y9JGoqwOeOPWbnt4CUpvIJbU1mMU4a11MNDZ7Sg5u9a"
X-TIMESTAMP: 2020-12-21T10:11:40+07:00
X-SIGNATURE:
85be817c55b2c135157c7e89f52499bf0c25ad6eebe04a986e8c86256
1b19a5
ORIGIN: www.hostname.com
X-PARTNER-ID: 82150823919040624621823174737537
X-EXTERNAL-ID: 41807553358950093184162180797837
X-IP-ADDRESS: 172.24.281.24
X-DEVICE-ID: 09864ADCASA
X-LATITUDE: -6.1617169
X-LONGITUDE: 106.6643946
CHANNEL-ID: 95221

{
  "partnerReferenceNo": "202010290000000000000001",

```

```
"beneficiaryAccountNo":"888801000157508",
"additionalInfo":{
  "deviceId":"12345679237",
  "channel":"mobilephone"
}
}
```

### Contoh Response

Content-type: application/json  
X-TIMESTAMP: 2020-12-21T10:11:44+07:00

```
{
  "responseCode":"2001500",
  "responseMessage":"Successful",
  "referenceNo":"2020102977770000000009",
  "partnerReferenceNo":"2020102900000000000001",
  "beneficiaryAccountName":"Yories Yolanda",
  "beneficiaryAccountNo":"888801000157508",
  "beneficiaryAccountStatus":"Rekening aktif",
  "beneficiaryAccountType":"D",
  "currency":"IDR",
  "additionalInfo":{
    "deviceId":"12345679237",
    "channel":"mobilephone"
  }
}
```

## 4.2.1.2. Eksternal Account Inquiry

### Sequence Diagram

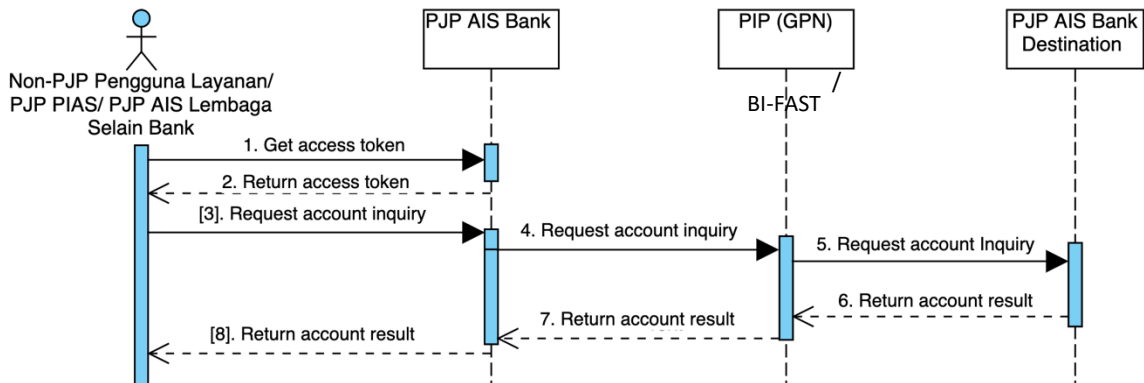

Sequence Diagram API External Account Inquiry

### Informasi Umum

<b>Service Code</b>	16
<b>Name</b>	API External Account Inquiry
<b>Version</b>	1.0
<b>HTTP Method</b>	POST
<b>Path</b>	.../{version}/account-inquiry-external

### Request Body

<b>Parameter</b>	<b>Data Type</b>	<b>Mandatory</b>	<b>Length</b>	<b>Description</b>	<b>Example</b>
beneficiaryBank Code	String	M	8	Beneficiary Bank Code	002
beneficiaryAccountNo	String	M	34	Beneficiary Account Number	888801000157508
partnerReferenceNo	String	O	64	Transaction identifier on service consumer system	20201029000000000001

<b>Parameter</b>	<b>Data Type</b>	<b>Mandatory</b>	<b>Length</b>	<b>Description</b>	<b>Example</b>
additionalInfo	Object	O	N/A	Additional information for custom use that are not provided by SNAP	{ "deviceId": "12345679237", "channel": "mobilephone", }

### Response Body

<b>Parameter</b>	<b>Data Type</b>	<b>Mandatory</b>	<b>Length</b>	<b>Description</b>	<b>Example</b>
responseCode	String	M	7	Response code	2001600
responseMessage	String	M	150	Response description	Successful
referenceNo	String	O	64	Transaction identifier on service provider system.	202010297 777000000 0009
partnerReferenceNo	String	O	64	Transaction identifier on service consumer system	202010290 000000000 0001
beneficiaryAccountName	String	M	100	Beneficiary Account Name	Yories Yolanda
beneficiaryAccountNo	String	M	34	Beneficiary Account Number	888801000 157508



<b>Parameter</b>	<b>Data Type</b>	<b>Mandatory</b>	<b>Length</b>	<b>Description</b>	<b>Example</b>
beneficiaryBank Code	String	O	8	Beneficiary Bank Code	002
beneficiaryBank Name	String	O	50	Beneficiary Bank Name	Bank BRI
currency	String	O	3	Currency Type	IDR
additionalInfo	Object	O	N/A	Additional information for custom use that are not provided by SNAP	{ "deviceId": "12345679237", "channel": "mobilephone", }

### Contoh Request

```
POST .../v1.0/account-inquiry-external HTTP/1.2
Content-type: application/json
Authorization: Bearer
gp9HjjEj813Y9JGoqwOeOPWbnt4CUpvIJbU1mMU4a11MNDZ7Sg5u9a"
Authorization-Customer: Bearer
fa8sjjEj813Y9JGoqwOeOPWbnt4CUpvIJbU1mMU4a11MNDZ7Sg5u9a"
X-TIMESTAMP: 2020-12-21T10:21:34+07:00
X-SIGNATURE:
85be817c55b2c135157c7e89f52499bf0c25ad6eeeb04a986e8c86256
1b19a5
ORIGIN: www.hostname.com
X-PARTNER-ID: 82150823919040624621823174737537
X-EXTERNAL-ID: 41807553358950093184162180797837
X-IP-ADDRESS: 172.24.281.24
X-DEVICE-ID: 09864ADCASA
X-LATITUDE: -6.1617169
X-LONGITUDE: 106.6643946
CHANNEL-ID: 95221
```

```
{
  "beneficiaryBankCode": "002",
  "beneficiaryAccountNo": "888801000157508",
  "partnerReferenceNo": "202010290000000000000001",
  "additionalInfo": {
    "deviceId": "12345679237",
    "channel": "mobilephone"
  }
}
```

```
}  
}
```

### Contoh Response

```
Content-type: application/json  
X-TIMESTAMP: 2020-12-21T10:21:40+07:00
```

```
{  
  "responseCode": "2001600",  
  "responseMessage": "Successful",  
  "referenceNo": "20201029777700000000009",  
  "partnerReferenceNo": "20201029000000000000001",  
  "beneficiaryAccountName": "Yories Yolanda",  
  "beneficiaryAccountNo": "888801000157508",  
  "beneficiaryBankCode": "002",  
  "beneficiaryBankName": "Bank BRI",  
  "currency": "IDR",  
  "additionalInfo": {  
    "deviceId": "12345679237",  
    "channel": "mobilephone"  
  }  
}
```

## 4.2.2. API Transfer

### 4.2.2.1. Intrabank Transfer

#### Sequence Diagram

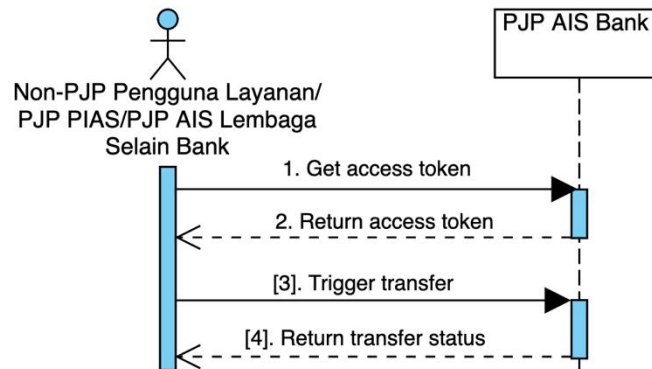

Sequence Diagram API Intrabank Transfer

#### Informasi Umum

<b>Service Code</b>	17
<b>Name</b>	API Intrabank Transfer
<b>Version</b>	1.0
<b>HTTP Method</b>	POST
<b>Path</b>	.../{version}/transfer-intrabank

#### Request Body

<b>Parameter</b>	<b>Data Type</b>	<b>Mandatory</b>	<b>Length</b>	<b>Description</b>	<b>Example</b>
partnerReferenceNo	String	M	64	Transaction identifier on service consumer system	2020102900 0000000000 01
amount	Object	M			
value	String	M	16,2	Net amount of the transaction.	12345678.0 0

<b>Parameter</b>	<b>Data Type</b>	<b>Mandatory</b>	<b>Length</b>	<b>Description</b>	<b>Example</b>
				If it's IDR then value includes 2 decimal digits. e.g. IDR 10.000,- will be placed with 10000.00	
currency	String	M	3	Currency (ISO 4217)	IDR
beneficiaryAccountNo	String	M	34	Beneficiary Account Number	888801000003301
beneficiaryEmail	String	O	50	Beneficiary Email	yories.yolanda@work.bri.co.id
currency	String	O	3	Currency Type	IDR
customerReference	String	O	30	Reference Number / No Referral / Transaction ID	10052019
feeType	String	O	25	To whom the fee will be charged:	BEN

<i>Parameter</i>	<i>Data Type</i>	<i>Mandatory</i>	<i>Length</i>	<i>Description</i>	<i>Example</i>
				<p><b>OUR</b> = Fee is charged to the sender (default)</p> <p><b>BEN</b> = Fee is charged to the recipient</p> <p><b>SHA   1000</b> = Fee is shared between sender and recipient, with sender is charged Rp 1.000,00 and the recipient will be charged the rest</p>	
remark	<i>String</i>	<i>O</i>	50	Remark/transaction description	remark test
sourceAccountNo	<i>String</i>	<i>M</i>	19	Source Account Number	888801000157508
transactionDate	<i>String</i>	<i>M</i>	25	Format transaction date: (ISO 8601) YYYY-	2019-07-03T12:08:56+07:00

<b>Parameter</b>	<b>Data Type</b>	<b>Mandatory</b>	<b>Length</b>	<b>Description</b>	<b>Example</b>
				MM-DDThh:mm:ss	
originatorInfos	Array of Objects	C		The Originator Customer Account Details  To be filled if there is a request from the sender or if the consent from sender has been granted.  This is subject to Article 8 paragraph 5 of Law No. 3 of 2011 concerning Fund Transfers.  Also check for other provisions, such as the PPATK regulation.	
originatorCustomerNo	String	M	34	Originator customer account number	99901000003301
originatorCustomerName	String	M	100	Originator customer account name	lin
originatorBankCode	String	M	8	Originator Bank Code	002
additionalInfo	Object	O	N/A	Additional information for custom use that are not provided by SNAP	{"deviceId": "12345679237", "channel": "mobilephone"}

## Response Body

<b>Parameter</b>	<b>Data Type</b>	<b>Mandatory</b>	<b>Length</b>	<b>Description</b>	<b>Example</b>
responseCode	<i>String</i>	<i>M</i>	7	Response code	2001700
responseMessage	<i>String</i>	<i>M</i>	150	Response description	Successful
referenceNo	<i>String</i>	<i>C</i>	64	Transaction identifier on service provider system.  Must be filled upon successful transaction	2020102977 7700000000 09
partnerReferenceNo	<i>String</i>	<i>O</i>	64	Transaction identifier on service consumer system	2020102900 0000000000 01
amount	<i>Object</i>	<i>O</i>			
value	<i>String</i>	<i>M</i>	16,2	Net amount of the transaction. If it's IDR then value includes 2 decimal digits. e.g. IDR 10.000,- will	12345678.00

<b>Parameter</b>	<b>Data Type</b>	<b>Mandatory</b>	<b>Length</b>	<b>Description</b>	<b>Example</b>
				be placed with 10000.00	
currency	String	M	3	Currency (ISO 4217)	IDR
beneficiaryAccountNo	String	M	34	Beneficiary Account	8888010000 03301
currency	String	O	3	Currency Type	IDR
customerReference	String	O	30	Reference Number / No Referral	10052019
sourceAccountNo	String	O	19	Source Account	8888010001 57508
transactionDate	String	M	25	Format transaction date: (ISO 8601) YYYY- MM- DDThh:mm:ss	2019-07- 03T12:08:56 +07:00
originatorInfos	Array of Objects	C		The Originator Customer Account Details  To be filled if there is a request from the sender or if the consent from sender has been granted. This is subject to Article 8 paragraph 5 of Law No. 3 of 2011 concerning Fund Transfers. Also check for other provisions, such as	



<b>Parameter</b>	<b>Data Type</b>	<b>Mandatory</b>	<b>Length</b>	<b>Description</b>	<b>Example</b>
				the PPATK regulation.	
originatorCustomerNo	String	M	34	Originator customer account number	9990100000 3301
originatorCustomerName	String	M	100	Originator customer account name	Iin
originatorBankCode	String	M	8	Originator Bank Code	002
additionalInfo	Object	O	N/A	Additional information for custom use that are not provided by SNAP	{"deviceId": "12345679237", "channel": "mobilephone"}

### Contoh Request

```

POST .../v1.0/transfer-intrabank HTTP/1.2
Content-type: application/json
Authorization: Bearer
gp9HjjEj813Y9JGoqwOeOPWbnt4CUpvIJbU1mMU4a11MNDZ7Sg5u9a"
Authorization-Customer: Bearer
fa8sjjEj813Y9JGoqwOeOPWbnt4CUpvIJbU1mMU4a11MNDZ7Sg5u9a"
X-TIMESTAMP: 2020-12-21T10:30:24+07:00
X-SIGNATURE:
85be817c55b2c135157c7e89f52499bf0c25ad6eebe04a986e8c86256
1b19a5
ORIGIN: www.hostname.com
X-PARTNER-ID: 82150823919040624621823174737537
X-EXTERNAL-ID: 41807553358950093184162180797837
X-IP-ADDRESS: 172.24.281.24
X-DEVICE-ID: 09864ADCASA
X-LATITUDE: -6.1617169
X-LONGITUDE: 106.6643946
CHANNEL-ID: 95221

{
  "partnerReferenceNo": "202010290000000000000001",

```

```

    "amount":{
      "value":"12345678.00",
      "currency":"IDR"
    },
    "beneficiaryAccountNo":"888801000003301",
    "beneficiaryEmail":"yories.yolanda@work.bri.co.id ",
    "currency":"IDR",
    "customerReference":"10052019",
    "feeType":"BEN",
    "remark":"remark test",
    "sourceAccountNo":"888801000157508",
    "transactionDate":"2019-07-03T12:08:56+07:00",
    "originatorInfos":[{
      "originatorCustomerNo":"99901000003301",
      "originatorCustomerName":"Iin"
      "originatorBankCode":"002"
    },
    {
      "originatorCustomerNo":"99901000003302",
      "originatorCustomerName":"Renaldy"
      "originatorBankCode":"002"
    },
    {
      "originatorCustomerNo":"99901000003303",
      "originatorCustomerName":"Aufar"
      "originatorBankCode":"002"
    }
  ],
  "additionalInfo":{
    "deviceId":"12345679237",
    "channel":"mobilephone"
  }
}

```

### Contoh Response

Content-type: application/json  
 X-TIMESTAMP: 2020-12-21T10:30:34+07:00

```

{
  "responseCode":"2001700",
  "responseMessage":"Successful",
  "referenceNo":"2020102977770000000009",
  "partnerReferenceNo":"2020102900000000000001",
  "amount":{
    "value":"12345678.00",
    "currency":"IDR"
  },
  "beneficiaryAccountNo":"888801000003301",
  "currency":"IDR",
  "customerReference":"10052019",
  "sourceAccount":"888801000157508",

```

```
"transactionDate":"2019-07-03T12:08:56+07:00",
"originatorInfos":[{
  "originatorCustomerNo":"99901000003301",
  "originatorCustomerName":"Iin"
  "originatorBankCode":"002"
},
{
  "originatorCustomerNo":"99901000003302",
  "originatorCustomerName":"Renaldy"
  "originatorBankCode":"002"
},
{
  "originatorCustomerNo":"99901000003303",
  "originatorCustomerName":"Aufar"
  "originatorBankCode":"002"
}],
"additionalInfo":{
  "deviceId":"12345679237",
  "channel":"mobilephone"
}
}
```

## 4.2.2.2. Interbank Transfer

### Sequence Diagram

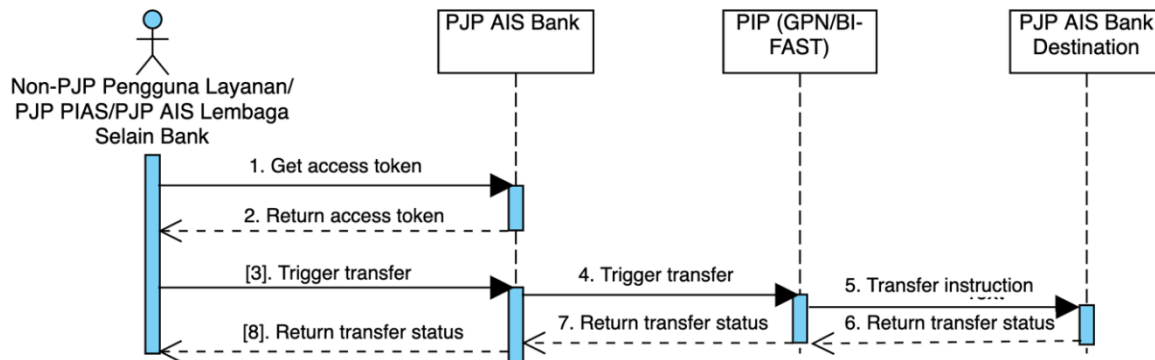

Sequence Diagram API Interbank Transfer

### Informasi Umum

<b>Service Code</b>	18
<b>Name</b>	API Interbank Transfer
<b>Version</b>	1.0
<b>HTTP Method</b>	POST
<b>Path</b>	.../{version}/transfer-interbank

### Request Body

<b>Parameter</b>	<b>Data Type</b>	<b>Mandatory</b>	<b>Length</b>	<b>Description</b>	<b>Example</b>
partnerReferenceNo	String	M	64	Transaction identifier on service consumer system	2020102900 0000000000 01
amount	Object	M			
value	String	M	16,2	Net amount of the transaction.	12345678.00

<b>Parameter</b>	<b>Data Type</b>	<b>Mandatory</b>	<b>Length</b>	<b>Description</b>	<b>Example</b>
				If it's IDR then value includes 2 decimal digits. e.g. IDR 10.000,- will be placed with 10000.00	
currency	String	M	3	Currency (ISO 4217)	IDR
beneficiaryAccountName	String	M	100	Beneficiary Account Name	Yories Yolanda
beneficiaryAccountNo	String	M	34	Beneficiary Account	888801000003301
beneficiaryAddress	String	O	100	Beneficiary Address	Palembang
beneficiaryBankCode	String	M	8	Beneficiary Bank Code	002
beneficiaryBankName	String	O	50	Beneficiary Bank Name	Bank BRI
beneficiaryEmail	String	O	50	Beneficiary Email	yories.yolanda@work.bri.co.id
currency	String	O	3	Currency Type	IDR

<b>Parameter</b>	<b>Data Type</b>	<b>Mandatory</b>	<b>Length</b>	<b>Description</b>	<b>Example</b>
customerReference	String	O	30	Reference Number / No Referral / Transaction ID	10052019
sourceAccountNo	String	M	19	Source Account Number	888801000157508
transactionDate	String	M	25	Format transaction date: (ISO 8601) YYYY-MM-DDThh:mm:ss	2019-07-03T12:08:56+07:00
feeType	String	O	25	To whom the fee will be charged:  <b>OUR</b> = Fee is charged to the sender (default) <b>BEN</b> = Fee is charged to the recipient <b>SHA   1000</b> = Fee is shared between sender and recipient,	BEN

<b>Parameter</b>	<b>Data Type</b>	<b>Mandatory</b>	<b>Length</b>	<b>Description</b>	<b>Example</b>
				with sender is charged Rp 1.000,00 and the recipient will be charged the rest	
originatorInfos	Array of Objects	C		The Originator Customer Account Details  To be filled if there is a request from the sender or if the consent from sender has been granted. This is subject to Article 8 paragraph 5 of Law No. 3 of 2011 concerning Fund Transfers. Also check for other provisions, such as the PPAATK regulation.	
originatorCustomerNo	String	M	34	Originator customer account number	55501000003301
originatorCustomerName	String	M	100	Originator customer account name	Yoda
originatorBankCode	String	M	8	Originator Bank Code	014

<b>Parameter</b>	<b>Data Type</b>	<b>Mandatory</b>	<b>Length</b>	<b>Description</b>	<b>Example</b>
additionalInfo	Object	O	N/A	Additional information for custom use that are not provided by SNAP	{ "deviceId": "12345679237", "channel": "mobilephone"} }

### Response Body

<b>Parameter</b>	<b>Data Type</b>	<b>Mandatory</b>	<b>Length</b>	<b>Description</b>	<b>Example</b>
responseCode	String	M	7	Response code	2001800
responseMessage	String	M	150	Response description	Successful
referenceNo	String	C	64	Transaction identifier on service provider system.  Must be filled upon successful transaction	2020102977 7700000000 09
partnerReferenceNo	String	O	64	Transaction identifier on service consumer system	2020102900 0000000000 01
amount	Object	O			



<b>Parameter</b>	<b>Data Type</b>	<b>Mandatory</b>	<b>Length</b>	<b>Description</b>	<b>Example</b>
value	<i>String</i>	M	16,2	Net amount of the transaction. If it's IDR then value includes 2 decimal digits. e.g. IDR 10.000,- will be placed with 10000.00	12345678.00
currency	<i>String</i>	M	3	Currency (ISO 4217)	IDR
beneficiaryAccountNo	<i>String</i>	M	19	Beneficiary Account Number	8888010000 03301
beneficiaryBankCode	<i>String</i>	O	8	Beneficiary Bank Code	002
sourceAccountNo	<i>String</i>	O	19	Source Account Number	8888010001 57508
traceNo	<i>String</i>	O	16	Number for tracking to destination bank	10052019
originatorInfos	<i>Array of</i>	C		The Originator Customer Account Details	

<b>Parameter</b>	<b>Data Type</b>	<b>Mandatory</b>	<b>Length</b>	<b>Description</b>	<b>Example</b>
	<i>Objects</i>			To be filled if there is a request from the sender or if the consent from sender has been granted. This is subject to Article 8 paragraph 5 of Law No. 3 of 2011 concerning Fund Transfers. Also check for other provisions, such as the PPATK regulation.	
originatorCustomerNo	<i>String</i>	<i>M</i>	34	Originator customer account number	5550100000 3301
originatorCustomerName	<i>String</i>	<i>M</i>	100	Originator customer account name	Yoda
originatorBankCode	<i>String</i>	<i>M</i>	8	Originator Bank Code	014
additionalInfo	<i>Object</i>	<i>O</i>	N/A	Additional information for custom use that are not provided by SNAP	{"deviceId": "12345679237", "channel": "mobilephone"}

### Contoh Request

```

POST .../v1.0/transfer-interbank HTTP/1.2
Content-type: application/json
Authorization: Bearer
gp9HjjEj813Y9JGoqwOeOPWbnt4CUpvIJbU1mMU4a11MNDZ7Sg5u9a"
Authorization-Customer: Bearer
fa8sjjEj813Y9JGoqwOeOPWbnt4CUpvIJbU1mMU4a11MNDZ7Sg5u9a"
X-TIMESTAMP: 2020-12-21T13:59:21+07:00
X-SIGNATURE:
85be817c55b2c135157c7e89f52499bf0c25ad6eebe04a986e8c86256
1b19a5

```

ORIGIN: www.hostname.com  
X-PARTNER-ID: 82150823919040624621823174737537  
X-EXTERNAL-ID: 41807553358950093184162180797837  
X-IP-ADDRESS: 172.24.281.24  
X-DEVICE-ID: 09864ADCASA  
X-LATITUDE: -6.1617169  
X-LONGITUDE: 106.6643946  
CHANNEL-ID: 95221

```
{
  "partnerReferenceNo":"2020102900000000000001",
  "amount":{
    "value":"12345678.00",
    "currency":"IDR"
  },
  "beneficiaryAccountName":"Yories Yolanda",
  "beneficiaryAccountNo":"888801000003301",
  "beneficiaryAddress":"Palembang",
  "beneficiaryBankCode":"002",
  "beneficiaryBankName":"Bank BRI",
  "beneficiaryEmail":"yories.yolanda@work.bri.co.id",
  "currency":"IDR",
  "customerReference":"10052019",
  "sourceAccountNo":"888801000157508",
  "transactionDate":"2019-07-03T12:08:56+07:00",
  "feeType":"OUR",
  "originatorInfos":[{
    "originatorCustomerNo":"55501000003301",
    "originatorCustomerName":"Yoda"
    "originatorBankCode":"014"
  },
  {
    "originatorCustomerNo":"55501000003302",
    "originatorCustomerName":"Hanung"
    "originatorBankCode":"022"
  },
  {
    "originatorCustomerNo":"55501000003303",
    "originatorCustomerName":"Adhi"
    "originatorBankCode":"009"
  }
  ],
  "additionalInfo":{
    "deviceId":"12345679237",
    "channel":"mobilephone"
  }
}
```

### Contoh Response

Content-type: application/json  
X-TIMESTAMP: 2020-12-21T13:59:40+07:00

```

{
  "responseCode": "2001800",
  "responseMessage": "Successful",
  "referenceNo": "2020102977770000000009",
  "partnerReferenceNo": "2020102900000000000001",
  "amount": {
    "value": "12345678.00",
    "currency": "IDR"
  },
  "beneficiaryAccountNo": "888801000003301",
  "beneficiaryBankCode": "002",
  "sourceAccountNo": "888801000157508",
  "traceNo": "10052019",
  "originatorInfos": [{
    "originatorCustomerNo": "55501000003301",
    "originatorCustomerName": "Yoda",
    "originatorBankCode": "014"
  },
  {
    "originatorCustomerNo": "55501000003302",
    "originatorCustomerName": "Hanung",
    "originatorBankCode": "022"
  },
  {
    "originatorCustomerNo": "55501000003303",
    "originatorCustomerName": "Adhi",
    "originatorBankCode": "009"
  }
  ],
  "additionalInfo": {
    "deviceId": "12345679237",
    "channel": "mobilephone"
  }
}

```

### 4.2.2.3. Request for Payment

#### Sequence Diagram

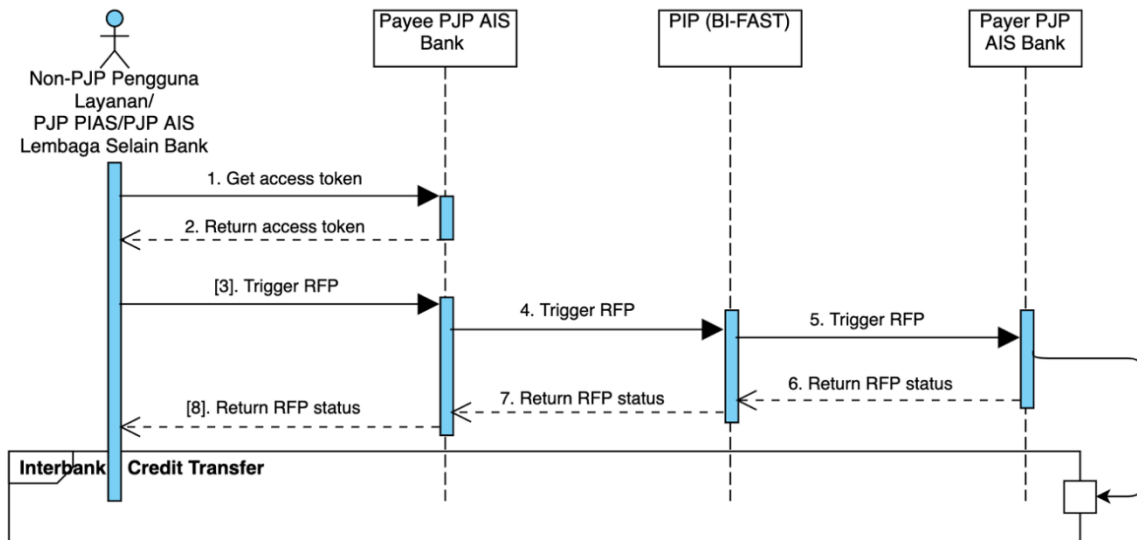

Sequence Diagram API Request for Payment

#### Informasi Umum

<b>Service Code</b>	19
<b>Name</b>	API Request for Payment
<b>Version</b>	1.0
<b>HTTP Method</b>	POST
<b>Path</b>	.../{version}/transfer-request-for-payment

#### Request Body

<b>Parameter</b>	<b>Data Type</b>	<b>Mandatory</b>	<b>Length</b>	<b>Description</b>	<b>Example</b>
partnerReferenceNo	String	M	64	Transaction identifier on service consumer system	20201029000000000001
bankCode	String	M	3	Beneficiary bank code	014

<b>Parameter</b>	<b>Data Type</b>	<b>Mandatory</b>	<b>Length</b>	<b>Description</b>	<b>Example</b>
				based on Bank Indonesia Code	
beneficiaryAccountNo	<i>String</i>	<i>M</i>	34	Beneficiary Account Number	888801000003301
beneficiaryAccountName	<i>String</i>	<i>M</i>	100	Beneficiary Account Name	Yories Yolanda
remark	<i>String</i>	<i>O</i>	50	Remark/transaction description	remark test
expiredDatetime	<i>String</i>	<i>M</i>	25	RFP expiration date and time  Format Expired Datetime (ISO 8601) YYYY-MM-DDThh:mm:ss	2022-12-22T08:01:16+07:00
sourceAccountNo	<i>String</i>	<i>M</i>	19	Source Account Number	888801000157508
sourceAccountName	<i>String</i>	<i>M</i>	100	Source Account Name	Yories Yolanda
currency	<i>String</i>	<i>O</i>	3	Currency Type	IDR
amount	<i>Object</i>	<i>O</i>			

<b>Parameter</b>	<b>Data Type</b>	<b>Mandatory</b>	<b>Length</b>	<b>Description</b>	<b>Example</b>
value	String	M	16,2	Net amount of the transaction. If it's IDR then value includes 2 decimal digits. e.g. IDR 10.000,- will be placed with 10000.00	12345678.00
currency	String	M	3	Currency (ISO 4217)	IDR
feeType	String	O	25	To whom the fee will be charged:  <b>OUR</b> = Fee is charged to the sender (default) <b>BEN</b> = Fee is charged to the recipient <b>SHA 1000</b> = Fee is shared between	BEN

<b>Parameter</b>	<b>Data Type</b>	<b>Mandatory</b>	<b>Length</b>	<b>Description</b>	<b>Example</b>
				sender and recipient, with sender is charged Rp 1.000,00 and the recipient will be charged the rest	
additionalInfo	Object	O	N/A	Additional information for custom use that are not provided by SNAP	{"deviceId": "12345679237", "channel": "mobilephone"}

### Response Body

<b>Parameter</b>	<b>Data Type</b>	<b>Mandatory</b>	<b>Length</b>	<b>Description</b>	<b>Example</b>
responseCode	String	M	7	Response code	2001900
responseMessage	String	M	150	Response description	Successful
referenceNo	String	C	64	Transaction identifier on service provider system.	20201029777 70000000009



<b>Parameter</b>	<b>Data Type</b>	<b>Mandatory</b>	<b>Length</b>	<b>Description</b>	<b>Example</b>
				Must be filled upon successful transaction	
partnerReferenceNo	String	O	64	Transaction identifier on service consumer system	202010290000000000001
additionalInfo	Object	O	N/A	Additional information for custom use that are not provided by SNAP	{"deviceId": "12345679237", "channel": "mobilephone"}

### Contoh Request

```
POST .../v1.0/transfer-request-for-payment HTTP/1.2
Content-type: application/json
Authorization: Bearer
gp9HjjEj813Y9JGoqwOeOPWbnt4CUpvIJbU1mMU4a11MNDZ7Sg5u9a"
Authorization-Customer: Bearer
fa8sJJjEj813Y9JGoqwOeOPWbnt4CUpvIJbU1mMU4a11MNDZ7Sg5u9a"
X-TIMESTAMP: 2020-12-22T08:01:16+07:00
X-SIGNATURE:
85be817c55b2c135157c7e89f52499bf0c25ad6eebe04a986e8c86256
1b19a5
ORIGIN: www.hostname.com
X-PARTNER-ID: 82150823919040624621823174737537
X-EXTERNAL-ID: 41807553358950093184162180797837
X-IP-ADDRESS: 172.24.281.24
X-DEVICE-ID: 09864ADCASA
X-LATITUDE: -6.1617169
X-LONGITUDE: 106.6643946
CHANNEL-ID: 95221
```

```
{
  "partnerReferenceNo": "202010290000000000000001",
```

```
"bankCode":"014",
"beneficiaryAccountNo":"888801000003301",
"beneficiaryAccountName":"Yories Yolanda",
"remark":"remark test",
"expiredDatetime":"2022-12-22T08:01:16+07:00",
"sourceAccountNo":"888801000157508",
"sourceAccountName":"Yories Yolanda",
"currency":"IDR",
"amount":{
  "value":"12345678.00",
  "currency":"IDR"
},
"feeType":"BEN",
"additionalInfo":{
  "deviceId":"12345679237",
  "channel":"mobilephone"
}
}
```

### Contoh Response

```
Content-type: application/json
X-TIMESTAMP: 2020-12-22T07:45:11+07:00
```

```
{
  "responseCode":"2001900",
  "responseMessage":"Successful",
  "referenceNo":"20201029777700000000009",
  "partnerReferenceNo":"20201029000000000000001",
  "additionalInfo":{
    "deviceId":"12345679237",
    "channel":"mobilephone"
  }
}
```

## 4.2.2.4. Interbank Transfer - Bulk

### a. Interbank Bulk Transfer

#### Sequence Diagram

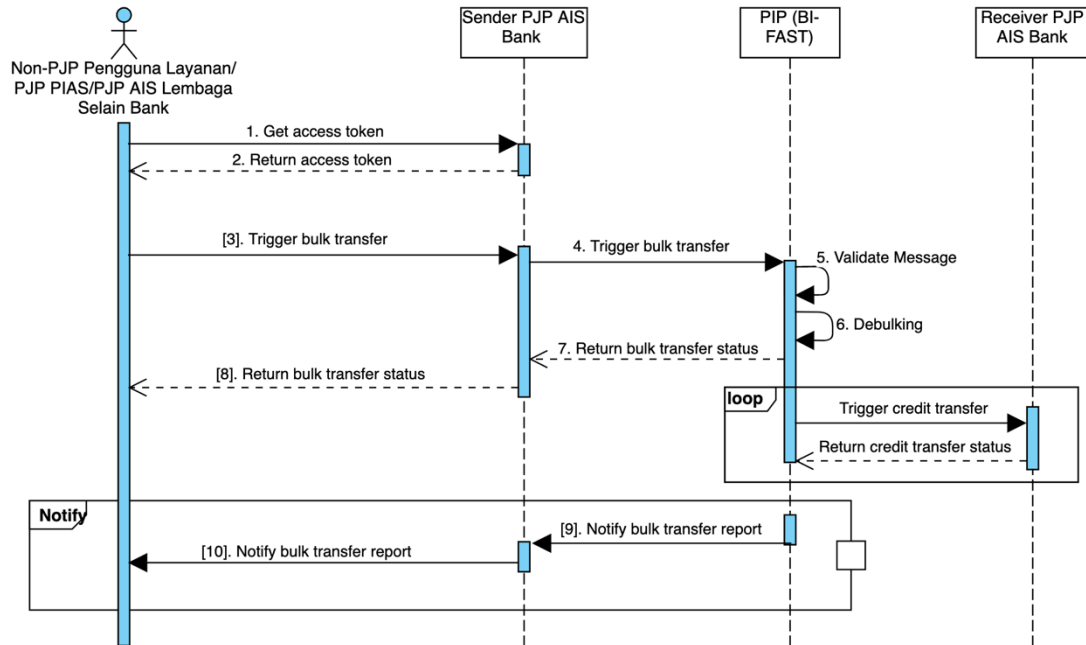

Sequence Diagram API Interbank Bulk Transfer

#### Informasi Umum

<b>Service Code</b>	20
<b>Name</b>	API Interbank Bulk Transfer
<b>Version</b>	1.0
<b>HTTP Method</b>	POST
<b>Path</b>	.../{version}/transfer-interbank-bulk

#### Request Body

Parameter	Data Type	Mandatory	Length	Description	Example
partnerBulkId	String	0	64	Bulk transaction identifier on service consumer (bulk	2020102900 0000000000 01

<b>Parameter</b>	<b>Data Type</b>	<b>Mandatory</b>	<b>Length</b>	<b>Description</b>	<b>Example</b>
				transaction sender) system	
currency	String	O	3	Currency Type	IDR
customerReference	String	M	30	Reference Number / No Referral / Transaction ID	10052019
feeType	String	O	25	<p>To whom the fee will be charged:</p> <p><b>OUR</b> = Fee is charged to the sender (default)</p> <p><b>BEN</b> = Fee is charged to the recipient</p> <p><b>SHA 1000</b> = Fee is shared between sender and recipient, with sender is charged Rp 1.000,00 and the recipient will be</p>	BEN

<b>Parameter</b>	<b>Data Type</b>	<b>Mandatory</b>	<b>Length</b>	<b>Description</b>	<b>Example</b>
				charged the rest	
remark	String	O	50	Remark/transaction description	Remark test
sourceAccountNo	String	M	19	Source Account Number	888801000157508
transactionDate	String	M	25	Format Transaction date (ISO 8601) YYYY-MM-DDThh:mm:ss	2019-07-03T12:08:56-07:00
bulkObject	Array of Objects				
partnerReferenceNo	String	M	64	Individual transaction identifier on service consumer (bulk transaction sender) system	20201029000000000990
bankCode	String	M	3	Bank code based on Bank	014

<b>Parameter</b>	<b>Data Type</b>	<b>Mandatory</b>	<b>Length</b>	<b>Description</b>	<b>Example</b>
				Indonesia Code	
beneficiaryAccountNo	String	M	34	Beneficiary Account Number	888801000003301
beneficiaryAccountName	String	M	100	Beneficiary Account Name	Yories Yolanda
amount	Object	M			
value	String	M	16,2	Net amount of the transaction. If it's IDR then value includes 2 decimal digits. e.g. IDR 10.000,- will be placed with 10000.00	12345678.00
currency	String	M	3	Currency (ISO 4217)	IDR
originatorInfos	Array of Objects	C		The Originator Customer Account Details  To be filled if there is a request from the sender or if the	

<b>Parameter</b>	<b>Data Type</b>	<b>Mandatory</b>	<b>Length</b>	<b>Description</b>	<b>Example</b>
				consent from sender has been granted. This is subject to Article 8 paragraph 5 of Law No. 3 of 2011 concerning Fund Transfers. Also check for other provisions, such as the PPAK regulation.	
originatorCustomerNo	String	M	34	Originator customer account number	55501000003301
originatorCustomerName	String	M	100	Originator customer account name	lin
originatorBankCode	String	M	8	Originator Bank Code	013
additionalInfo	Object	O	N/A	Additional information for custom use that are not provided by SNAP	{"deviceId": "12345679237", "channel": "mobilephone"}

### Response Body

<b>Parameter</b>	<b>Data Type</b>	<b>Mandatory</b>	<b>Length</b>	<b>Description</b>	<b>Example</b>
responseCode	String	M	7	Response code	2002000
responseMessage	String	M	150	Response description	Successful

<b>Parameter</b>	<b>Data Type</b>	<b>Mandatory</b>	<b>Length</b>	<b>Description</b>	<b>Example</b>
bulkId	String	C	64	Transaction identifier on service provider (Bulk transaction processing) system.  Must be filled upon successful transaction	2020102977 7700000000 09
partnerBulkId	String	O	64	Transaction identifier on service consumer (Bulk transaction sender) system	2020102900 0000000000 01
additionalInfo	Object	O	N/A	Additional information for custom use that are not provided by SNAP	{"deviceId": "12345679237", "channel": "mobilephone"}

### Contoh Request

```
POST .../v1.0/transfer-interbank-bulk HTTP/1.2
Content-type: application/json
```



Authorization: Bearer  
gp9HjjEj813Y9JGoqwOeOPWbnt4CUpvIJbU1mMU4a11MNDZ7Sg5u9a"  
Authorization-Customer: Bearer  
fa8sjjEj813Y9JGoqwOeOPWbnt4CUpvIJbU1mMU4a11MNDZ7Sg5u9a"  
X-TIMESTAMP: 2020-12-22T07:41:11+07:00  
X-SIGNATURE:  
85be817c55b2c135157c7e89f52499bf0c25ad6eebe04a986e8c86256  
1b19a5  
ORIGIN: www.hostname.com  
X-PARTNER-ID: 82150823919040624621823174737537  
X-EXTERNAL-ID: 41807553358950093184162180797837  
X-IP-ADDRESS: 172.24.281.24  
X-DEVICE-ID: 09864ADCASA  
X-LATITUDE: -6.1617169  
X-LONGITUDE: 106.6643946  
CHANNEL-ID: 95221

```
{  
  "partnerBulkId":"202010290000000000000001",  
  "currency":"IDR",  
  "customerReference":"10052019",  
  "feeType":"BEN",  
  "remark":"remark test",  
  "sourceAccountNo":"888801000157508",  
  "transactionDate":"2019-07-03T12:08:56-07:00",  
  "bulkObject": [  
    {  
      "partnerReferenceNo":"20201029000000000000990",  
      "bankCode":"014",  
      "beneficiaryAccountNo":"888801000003301",  
      "beneficiaryAccountName":"Yories Yolanda",  
      "amount": {  
        "value":"12345678.00",  
        "currency":"IDR"  
      },  
    },  
    "originatorInfos": [{  
      "originatorCustomerNo":"55501000003301",  
      "originatorCustomerName":"iin"  
      "originatorBankCode":"013"  
    },  
    {  
      "originatorCustomerNo":"55501000003302",  
      "originatorCustomerName":"Renaldy"  
      "originatorBankCode":"111"  
    },  
    {  
      "originatorCustomerNo":"55501000003303",  
      "originatorCustomerName":"Aufar"  
      "originatorBankCode":"008"  
    }  
  ]  
},
```

```
    "additionalInfo":{
      "deviceId":"12345679237",
      "channel":"mobilephone"
    }
  }
```

### **Contoh Response**

```
Content-type: application/json
X-TIMESTAMP: 2020-12-22T07:45:11+07:00
X-SIGNATURE:
85be8171923ac135157c7e89f52499bf0c25ad6eebe04a986e8c86256
1b19a5
```

```
{
  "responseCode":"2002000",
  "responseMessage":"Successful",
  "bulkId":"2020102977770000000009",
  "partnerBulkId ":"2020102900000000000001",
  "additionalInfo":{
    "deviceId":"12345679237",
    "channel":"mobilephone"
  }
}
```

## b. Notify

### Sequence Diagram

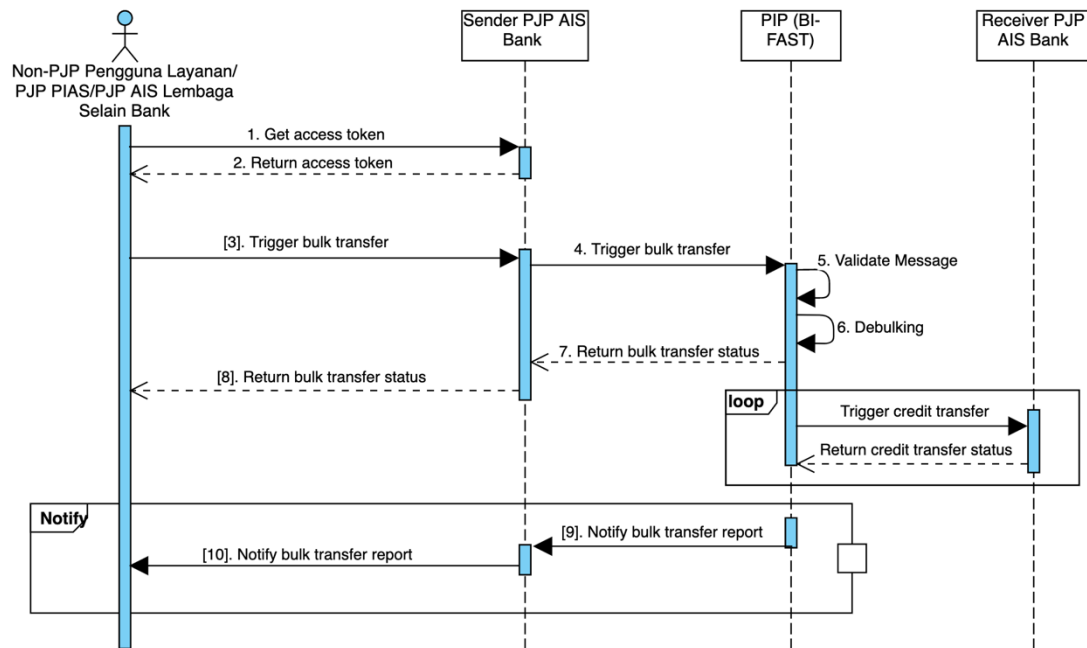

Sequence Diagram API Interbank Bulk Transfer Notification

### Informasi Umum

<b>Service Code</b>	21
<b>Name</b>	API Interbank Bulk Transfer Notification
<b>Version</b>	1.0
<b>HTTP Method</b>	POST
<b>Path</b>	.../{version}/transfer-interbank-bulk/notify

### Request Body

<i>Parameter</i>	<i>Data Type</i>	<i>Mandatory</i>	<i>Length</i>	<i>Description</i>	<i>Example</i>
bulkId	String	M	64	Transaction identifier on bulk transaction processing system	20201029777 70000000009

<b>Parameter</b>	<b>Data Type</b>	<b>Mandatory</b>	<b>Length</b>	<b>Description</b>	<b>Example</b>
partnerBulkId	String	M	64	Transaction identifier on bulk transaction sender system	20201029000 00000000001
bulkObject	Array of Objects				
originalReferenceNo	String	C	64	Individual transaction identifier on bulk transaction processing system.  Must be filled upon successful original transaction	20201029777 70000000009
originalPartnerReferenceNo	String	O	64	Individual transaction identifier on bulk transaction sender system	20201029000 00000000990

<b>Parameter</b>	<b>Data Type</b>	<b>Mandatory</b>	<b>Length</b>	<b>Description</b>	<b>Example</b>
responseCode	String	M	7	Response Code	2002100
responseMessage	String	M	150	Response description	Successful
amount	Object	O			
value	String	M	16,2	Net amount of the transaction. If it's IDR then value includes 2 decimal digits. e.g. IDR 10.000,- will be placed with 10000.00	12345678.00
currency	String	M	3	Currency (ISO 4217)	IDR
beneficiaryAccountNo	String	M	34	Beneficiary Account	888801000003301
beneficiaryBankCode	String	O	8	Beneficiary Bank Code	002
sourceAccountNo	String	M	19	Source Account Number	888801000157508
traceNo	String	O	16	Number for tracking to	10052019

<b>Parameter</b>	<b>Data Type</b>	<b>Mandatory</b>	<b>Length</b>	<b>Description</b>	<b>Example</b>
				destination bank	
additionalInfo	Object	O	N/A	Additional information for custom use that are not provided by SNAP	{"deviceId": "12345679237", "channel": "mobilephone"}

### Response Body

<b>Parameter</b>	<b>Data Type</b>	<b>Mandatory</b>	<b>Length</b>	<b>Description</b>	<b>Example</b>
responseCode	String	M	7	Response code	2002100
responseMessage	String	M	150	Response description	Successful
bulkId	String	M	64	Transaction identifier on bulk transaction processing system	2020102977770000000009
partnerBulkId	String	M	64	Transaction identifier on bulk transaction sender system	20201029000000000001
additionalInfo	Object	O	N/A	Additional information	{"deviceId": "12345679237",

<b>Parameter</b>	<b>Data Type</b>	<b>Mandatory</b>	<b>Length</b>	<b>Description</b>	<b>Example</b>
				for custom use that are not provided by SNAP	"channel": "mobilephone"}

### Contoh Request

```
POST .../v1.0/transfer-interbank-bulk/notify HTTP/1.2
Content-type: application/json
Authorization: Bearer
gp9HjjEj813Y9JGoqwOeOPWbnt4CUpvIJbU1mMU4a11MNDZ7Sg5u9a"
Authorization-Customer: Bearer
fa8sjjEj813Y9JGoqwOeOPWbnt4CUpvIJbU1mMU4a11MNDZ7Sg5u9a"
X-TIMESTAMP: 2020-12-22T07:53:16+07:00
X-SIGNATURE:
85be817c55b2c135157c7e89f52499bf0c25ad6eebe04a986e8c86256
1b19a5
ORIGIN: www.hostname.com
X-PARTNER-ID: 82150823919040624621823174737537
X-EXTERNAL-ID: 41807553358950093184162180797837
X-IP-ADDRESS: 172.24.281.24
X-DEVICE-ID: 09864ADCASA
X-LATITUDE: -6.1617169
X-LONGITUDE: 106.6643946
CHANNEL-ID: 95221
```

```
{
  "bulkId": "20201029777700000000009",
  "partnerBulkId": "20201029000000000000001",
  "bulkObject": [
    {
      "originalReferenceNo": "20201029777700000000009",
      "originalPartnerReferenceNo": "20201029000000000000990",
      "responseCode": "2000000",
      "responseMessage": "Successful",
      "amount": {
        "value": "12345678.00",
        "currency": "IDR"
      },
      "beneficiaryAccountNo": "888801000003301",
      "beneficiaryBankCode": "002",
      "sourceAccountNo": "888801000157508",
      "traceNo": "10052019"
    }
  ],
}
```

```
    "additionalInfo":{
      "deviceId":"12345679237",
      "channel":"mobilephone"
    }
  }
```

### **Contoh Response**

Content-type: application/json  
X-TIMESTAMP: 2020-12-22T07:53:21+07:00

```
{
  "responseCode":"2002100",
  "responseMessage":"Successful",
  "bulkId":"2020102977770000000009",
  "partnerBulkId":"2020102900000000000001",
  "additionalInfo":{
    "deviceId":"12345679237",
    "channel":"mobilephone"
  }
}
```



## 4.2.2.5. RTGS Transfer

### Sequence Diagram

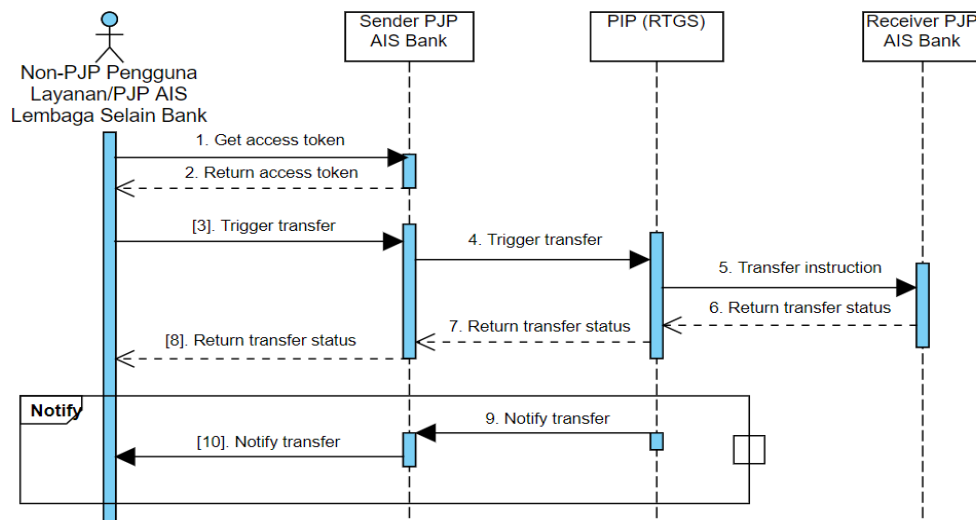

Sequence Diagram API Transfer RTGS

#### a. Transfer RTGS

##### Informasi Umum

<b>Service Code</b>	22
<b>Name</b>	API Transfer RTGS
<b>Version</b>	1.0
<b>HTTP Method</b>	POST
<b>Path</b>	.../{version}/transfer-rtgs

##### Request Body

<b>Parameter</b>	<b>Data Type</b>	<b>Mandatory</b>	<b>Length</b>	<b>Description</b>	<b>Example</b>
partnerReferenceNo	String	M	64	Transaction identifier on service consumer system	20201029000000000001
amount	Object	M			

<b>Parameter</b>	<b>Data Type</b>	<b>Mandatory</b>	<b>Length</b>	<b>Description</b>	<b>Example</b>
value	String	M	16,2	Net amount of the transaction. If it's IDR then value includes 2 decimal digits. e.g. IDR 10.000,- will be placed with 10000.00	12345678.00
currency	String	M	3	Currency (ISO 4217)	IDR
beneficiaryAccountName	String	M	100	Beneficiary Account Name	Yories Yolanda
beneficiaryAccountNo	String	M	34	Beneficiary Account	888801000003301
beneficiaryAddress	String	O	100	Beneficiary Address	Palembang
beneficiaryBankCode	String	M	8	Beneficiary Bank Code	002
beneficiaryBankName	String	O	50	Beneficiary Bank Name	Bank BRI

<b>Parameter</b>	<b>Data Type</b>	<b>Mandatory</b>	<b>Length</b>	<b>Description</b>	<b>Example</b>
beneficiaryCustomerResidence	String	M	1	Beneficiary Customer Residence <b>1</b> = Indonesia <b>2</b> = Non Indonesia	1
beneficiaryCustomerType	String	M	1	Beneficiary Customer Type <b>1</b> = Individual <b>2</b> = Corporation <b>3</b> = Government	1
beneficiaryEmail	String	O	50	Beneficiary Email	yories.yolanda@work.bri.co.id
currency	String	O	3	Currency Type	IDR
customerReference	String	O	30	Reference Number / No Referral / Transaction ID	10052019
feeType	String	O	25	To whom the fee will be charged  <b>OUR</b> = Fee is charged to the sender (default)	BEN

<b>Parameter</b>	<b>Data Type</b>	<b>Mandatory</b>	<b>Length</b>	<b>Description</b>	<b>Example</b>
				<b>BEN</b> = Fee is charged to the recipient <b>SHA  1000</b> = Fee is shared between sender and recipient, with sender is charged Rp 1.000,00 and the recipient will be charged the rest	
kodepos	<i>String</i>	<i>O</i>	10	Sender City (kodepos)	12550
receiverPhone	<i>String</i>	<i>O</i>	20	Beneficiary Customer Phone	080901020304
remark	<i>String</i>	<i>O</i>	50	Remark/transaction description	remark test
senderCustomerResidence	<i>String</i>	<i>O</i>	1	Beneficiary Customer Residence <b>1</b> = Indonesia <b>2</b> = Non Indonesia	1

<b>Parameter</b>	<b>Data Type</b>	<b>Mandatory</b>	<b>Length</b>	<b>Description</b>	<b>Example</b>
senderCustomer Type	String	O	1	Beneficiary Customer Type 1 = Individual 2 = Corporation 3 = Government	1
senderPhone	String	O	20	Source Customer Phone	080901020304
sourceAccount No	String	M	19	Source Account Number	888801000157508
originatorInfos	Array of Objects	C		The Originator Customer Account Details  To be filled if there is a request from the sender or if the consent from sender has been granted. This is subject to Article 8 paragraph 5 of Law No. 3 of 2011 concerning Fund Transfers. Also check for other provisions, such as the PPATK regulation.	
originatorCustomerNo	String	M	34	Originator customer account number	77701000003301
originatorCustomerName	String	M	100	Originator customer account name	Yoda

<b>Parameter</b>	<b>Data Type</b>	<b>Mandatory</b>	<b>Length</b>	<b>Description</b>	<b>Example</b>
originatorBankCode	String	M	8	Originator Bank Code	014
transactionDate	String	M	25	Format date: (ISO 8601) YYYY-MM-DDThh:mm:ss	2019-07-03T12:08:56+07:00
additionalInfo	Object	O	N/A	Additional information for custom use that are not provided by SNAP	{ "deviceId": "12345679237", "channel": "mobilephone"}

### Response Body

<b>Parameter</b>	<b>Data Type</b>	<b>Mandatory</b>	<b>Length</b>	<b>Description</b>	<b>Example</b>
responseCode	String	M	7	Response code	2002200
responseMessage	String	M	150	Response description	Successful
referenceNo	String	C	64	Transaction identifier on service provider system.  Must be filled upon successful transaction	202010297 777000000 0009

<b>Parameter</b>	<b>Data Type</b>	<b>Mandatory</b>	<b>Length</b>	<b>Description</b>	<b>Example</b>
partnerReferenceNo	<i>String</i>	<i>O</i>	64	Transaction identifier on service consumer system	202010290 000000000 0001
amount	<i>Object</i>	<i>O</i>			
value	<i>String</i>	<i>M</i>	16,2	Net amount of the transaction. If it's IDR then value includes 2 decimal digits. e.g. IDR 10.000,- will be placed with 10000.00	12345678.0 0
currency	<i>String</i>	<i>M</i>	3	Currency (ISO 4217)	IDR
beneficiaryAccountName	<i>String</i>	<i>M</i>	100	Beneficiary Account Name	Yories Yolanda
beneficiaryAccountNo	<i>String</i>	<i>M</i>	34	Beneficiary Account	888801000 003301
beneficiaryAccountType	<i>String</i>	<i>O</i>	1	Beneficiary Account Type	D

<b>Parameter</b>	<b>Data Type</b>	<b>Mandatory</b>	<b>Length</b>	<b>Description</b>	<b>Example</b>
				<b>D</b> = Current Account <b>S</b> = Saving Account	
beneficiaryBank Code	<i>String</i>	<i>O</i>	8	Beneficiary Bank Code	002
currency	<i>String</i>	<i>O</i>	3	Currency Type	IDR
customerReference	<i>String</i>	<i>O</i>	30	Reference Number / No Referral / Transaction ID	10052019
sourceAccount No	<i>String</i>	<i>M</i>	19	Source Account Number	888801000 157508
originatorInfos	<i>Array of Objects</i>	<i>C</i>		The Originator Customer Account Details  To be filled if there is a request from the sender or if the consent from sender has been granted. This is subject to Article 8 paragraph 5 of Law No. 3 of 2011 concerning Fund Transfers. Also check for other provisions, such	



<b>Parameter</b>	<b>Data Type</b>	<b>Mandatory</b>	<b>Length</b>	<b>Description</b>	<b>Example</b>
				as the PPATK regulation.	
originatorCustomerNo	String	M	34	Originator customer account number	777010000 03301
originatorCustomerName	String	M	100	Originator customer account name	Yoda
originatorBankCode	String	M	8	Originator Bank Code	014
traceNo	String	O	16	Number for tracking to destination bank	10052019
transactionDate	String	M	25	Transaction date : ISO 8601	2019-07-03T12:08:56-07:00
transactionStatus	String	M	2	<b>00</b> = Success <b>01</b> = Initiated <b>02</b> = Paying <b>03</b> = Pending <b>04</b> = Refunded <b>05</b> = Canceled <b>06</b> = Failed <b>07</b> = Not found	00
transactionStatusDesc	String	O	50	Description status transaction	Success
additionalInfo	Object	O	N/A	Additional information for custom use that are not	{"deviceId": "12345679237", "channel": "mobilephone"}

<b>Parameter</b>	<b>Data Type</b>	<b>Mandatory</b>	<b>Length</b>	<b>Description</b>	<b>Example</b>
				provided by SNAP	

### Contoh Request

```

POST .../v1.0/transfer-rtgs HTTP/1.2
Content-type: application/json
Authorization: Bearer
gp9HjjEj813Y9JGoqwOeOPWbnt4CUpvIJbU1mMU4a11MNDZ7Sg5u9a"
Authorization-Customer: Bearer
fa8sjjEj813Y9JGoqwOeOPWbnt4CUpvIJbU1mMU4a11MNDZ7Sg5u9a"
X-TIMESTAMP: 2020-12-21T14:06:21+07:00
X-SIGNATURE:
85be817c55b2c135157c7e89f52499bf0c25ad6eebe04a986e8c86256
1b19a5
ORIGIN: www.hostname.com
X-PARTNER-ID: 821508239190406246218231777375374X- EXTERNAL-
ID: 418075533589500931841621807978377X- IP-ADDRESS:
172.24.281.247X- DEVICE-ID: 09864ADCASA7X- LATITUDE: -
6.16171697X- LONGITUDE: 106.66439467CHANNEL-ID:
95221766439467CHANNEL-ID: 952217{
  "partnerReferenceNo":"202010290000000000000001",
  "amount":{
    "value":"12345678.00",
    "currency":"IDR"
  },
  "beneficiaryAccountName":"Yories Yolanda",
  "beneficiaryAccountNo":"888801000003301",
  "beneficiaryAddress":"Palembang",
  "beneficiaryBankCode":"002",
  "beneficiaryBankName":"Bank BRI",
  "beneficiaryCustomerResidence":"1",
  "beneficiaryCustomerType":"1",
  "beneficiaryEmail":"yories.yolanda@work.bri.co.id",
  "currency":"IDR",
  "customerReference":"10052019",
  "feeType":"BEN",
  "kodepos":"12250",
  "receiverPhone":"080901020304",
  "remark":"remark test",
  "senderCustomerResidence":"1",
  "senderCustomerType":"1",
  "senderPhone":"080901020304",
  "sourceAccountNo":"888801000157508",
  "originatorInfos":[{
    "originatorCustomerNo":"55501000003301",

```

```

    "originatorCustomerName":"Yoda"
    "originatorBankCode":"014"
  },
  {
    "originatorCustomerNo":"55501000003302",
    "originatorCustomerName":"Hanung"
    "originatorBankCode":"022"
  },
  {
    "originatorCustomerNo":"55501000003303",
    "originatorCustomerName":"Adhi"
    "originatorBankCode":"009"
  }
],
"transactionDate":"2019-07-03T12:08:56+07:00",
"additionalInfo":{
  "deviceId":"12345679237",
  "channel":"mobilephone"
}
}

```

### Contoh Response

```

Content-type: application/json
X-TIMESTAMP: 2020-12-21T14:06:31+07:00
X-SIGNATURE:
85be8171923ac135157c7e89f52499bf0c25ad6eebe04a986e8c86256
1b19a5

```

```

{
  "responseCode":"2002200",
  "responseMessage":"Successful",
  "referenceNo":"2020102977770000000009",
  "partnerReferenceNo":"2020102900000000000001",
  "amount":{
    "value":"12345678.00",
    "currency":"IDR"
  },
  "beneficiaryAccountName":"Yories Yolanda",
  "beneficiaryAccountNo":"888801000003301",
  "beneficiaryAccountType":"D",
  "beneficiaryBankCode":"002",
  "currency":"IDR",
  "customerReference":"10052019",
  "sourceAccountNo":"888801000157508",
  "originatorInfos":[{
    "originatorCustomerNo":"55501000003301",
    "originatorCustomerName":"Yoda"
    "originatorBankCode":"014"
  },
  {
    "originatorCustomerNo":"55501000003302",

```

```
    "originatorCustomerName":"Hanung"
    "originatorBankCode":"022"
  },
  {
    "originatorCustomerNo":"55501000003303",
    "originatorCustomerName":"Adhi"
    "originatorBankCode":"009"
  }
],
"traceNo":"10052019",
"transactionDate":"2019-07-03T12:08:56+07:00",
"transactionStatus":"00",
"transactionStatusDesc":"success",
"additionalInfo":{
  "deviceId":"12345679237",
  "channel":"mobilephone"
}
}
```

## b. Notify RTGS

### Informasi Umum

<b>Service Code</b>	76
<b>Name</b>	API RTGS Notification
<b>Version</b>	1.0
<b>HTTP Method</b>	POST
<b>Path</b>	.../{version}/transfer-rtgs/notify

### Request Body

<i>Parameter</i>	<i>Data Type</i>	<i>Mandatory</i>	<i>Length</i>	<i>Description</i>	<i>Example</i>
originalPartnerReferenceNo	String	O	64	Original transaction identifier on service consumer system	20201029000000000001
originalReferenceNo	String	O	64	Original transaction identifier on service provider system	2020102977770000000009
originalExternalId	String	O	19	Original Customer Reference Number	10052019
latestTransactionStatus	String	M	2	<b>00</b> = Success <b>01</b> = Initiated <b>02</b> = Paying <b>03</b> = Pending <b>04</b> = Refunded <b>05</b> = Canceled	00

<b>Parameter</b>	<b>Data Type</b>	<b>Mandatory</b>	<b>Length</b>	<b>Description</b>	<b>Example</b>
				<b>06</b> = Failed <b>07</b> = Not found	
amount	Object	O			
value	String	M	16,2	Net amount of the transaction. If it's IDR then value includes 2 decimal digits. e.g. IDR 10.000,- will be placed with 10000.00	10000.00
currency	String	M	3	Currency (ISO 4217)	IDR
beneficiaryAccountName	String	M	100	Beneficiary Account Name	Yories Yolanda
beneficiaryAccountNo	String	M	34	Beneficiary Account	888801000003301
beneficiaryBankCode	String	M	8	Beneficiary Bank Code	002
sourceAccountNo	String	M	19	Beneficiary Bank Code	888801000157508
transactionDate	String	M	25	Format transaction	2020-12-21T14:06:2

<b>Parameter</b>	<b>Data Type</b>	<b>Mandatory</b>	<b>Length</b>	<b>Description</b>	<b>Example</b>
				date: (ISO 8601) YYYY-MM-DDThh:mm:ss	1+07:00
additionalInfo	Object	O	N/A	Additional information for custom use that are not provided by SNAP	{"deviceId": "12345679237", "channel": "mobilephone"}

### Response Body

<b>Parameter</b>	<b>Data Type</b>	<b>Mandatory</b>	<b>Length</b>	<b>Description</b>	<b>Example</b>
responseCode	String	M	7	Response code	2007600
responseMessage	String	M	150	Response description	Successful

### Contoh Request

```

POST .../v1.0/transfer-rtgs/notify HTTP/1.2
Content-type: application/json
Authorization: Bearer
gp9HjjEj813Y9JGoqwOeOPWbnt4CUpvIJbU1mMU4a11MNDZ7Sg5u9a"
Authorization-Customer: Bearer
fa8sjjEj813Y9JGoqwOeOPWbnt4CUpvIJbU1mMU4a11MNDZ7Sg5u9a"
X-TIMESTAMP: 2020-12-22T07:53:16+07:00
X-SIGNATURE:
85be817c55b2c135157c7e89f52499bf0c25ad6eebe04a986e8c86256
1b19a5
ORIGIN: www.hostname.com
X-PARTNER-ID: 82150823919040624621823174737537
X-EXTERNAL-ID: 41807553358950093184162180797837
X-IP-ADDRESS: 172.24.281.24
X-DEVICE-ID: 09864ADCASA
X-LATITUDE: -6.1617169
X-LONGITUDE: 106.6643946

```

CHANNEL-ID: 95221

```
{
  "originalPartnerReferenceNo":"202010290000000000000001",
  "originalReferenceNo":"202010297777000000000009",
  "originalExternalId":"10052019",
  "latestTransactionStatus":"00",
  "amount":{
    "value":"10000.00",
    "currency":"IDR"
  },
  "beneficiaryAccountName":"Yories Yolanda",
  "beneficiaryAccountNo":"888801000003301",
  "beneficiaryBankCode":"002",
  "sourceAccountNo":"888801000157508",

  "transactionDate":"2020-12-21T14:06:21+07:00",
  "additionalInfo":{
    "deviceId":"12345679237",
    "channel":"mobilephone"
  }
}
```

### **Contoh Response**

Content-type: application/json

X-TIMESTAMP: 2020-12-22T07:53:21+07:00

```
{
  "responseCode":"2007600",
  "responseMessage":"Successful"
}
```



## 4.2.2.6. SKNBI Transfer

### a. Transfer SKNBI

#### Sequence Diagram

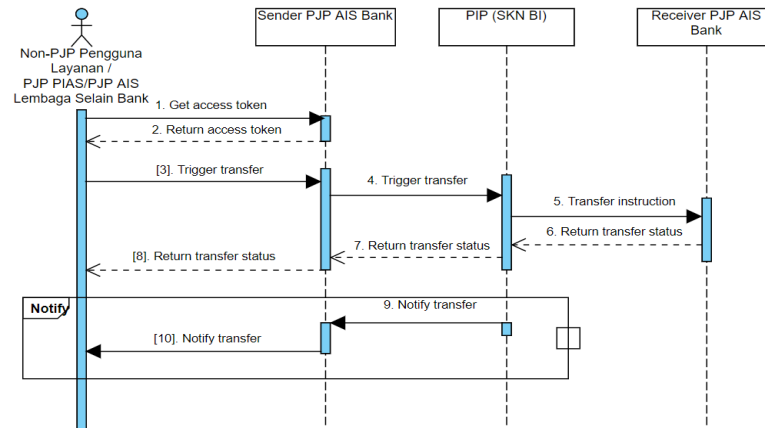

Sequence Diagram API Transfer SKNBI

#### Informasi Umum

<b>Service Code</b>	23
<b>Name</b>	API Transfer SKNBI
<b>Version</b>	1.0
<b>HTTP Method</b>	POST
<b>Path</b>	.../{version}/transfer-skn

#### Request Body

<b>Parameter</b>	<b>Data Type</b>	<b>Mandatory</b>	<b>Length</b>	<b>Description</b>	<b>Example</b>
partnerReferenceNo	String	M	64	Transaction identifier on service consumer system	2020102900 0000000000 01
amount	Object	O			
value	String	M	16,2	Net amount of the transaction.	12345678.00

<b>Parameter</b>	<b>Data Type</b>	<b>Mandatory</b>	<b>Length</b>	<b>Description</b>	<b>Example</b>
				If it's IDR then value includes 2 decimal digits. e.g. IDR 10.000,- will be placed with 10000.00	
currency	String	M	3	Currency (ISO 4217)	IDR
beneficiaryAccountName	String	M	100	Beneficiary Account Name	Yories Yolanda
beneficiaryAccountNo	String	M	34	Beneficiary Account	888801000157508
beneficiaryAddress	String	O	100	Beneficiary Address	Palembang
beneficiaryBankCode	String	M	8	Beneficiary Bank Code	002
beneficiaryBankName	String	O	50	Beneficiary Bank Name	Bank BRI
beneficiaryCustomerResidence	String	M	1	Beneficiary Customer Residence <b>1</b> = Indonesia <b>2</b> = Non Indonesia	1

<b>Parameter</b>	<b>Data Type</b>	<b>Mandatory</b>	<b>Length</b>	<b>Description</b>	<b>Example</b>
beneficiaryCustomerType	String	M	1	Beneficiary Customer Type <b>1</b> = Individual <b>2</b> = Corporation <b>3</b> = Government	1
beneficiaryEmail	String	O	50	Beneficiary Email	yories.yolanda@work.bri.co.id
currency	String	O	3	Currency Type	IDR
customerReference	String	O	30	Reference Number / No Referral / Transaction ID	10052019
feeType	String	O	25	To whom the fee will be charged:  <b>OUR</b> = Fee is charged to the sender (default) <b>BEN</b> = Fee is charged to the recipient <b>SHA 1000</b> = Fee is shared between sender and recipient, with sender is	BEN

<b>Parameter</b>	<b>Data Type</b>	<b>Mandatory</b>	<b>Length</b>	<b>Description</b>	<b>Example</b>
				charged Rp 1.000,00 and the recipient will be charged the rest	
kodepos	<i>String</i>	<i>O</i>	10	Sender City (kodepos)	12250
receiverPhone	<i>String</i>	<i>O</i>	20	Beneficiary Customer Phone	080901020304
remark	<i>String</i>	<i>O</i>	50	Remark/transaction description	Remark test
senderCustomerResidence	<i>String</i>	<i>O</i>	1	Beneficiary Customer Residence <b>1</b> = Indonesia <b>2</b> = Non Indonesia	1
senderCustomerType	<i>String</i>	<i>O</i>	1	Beneficiary Customer Type <b>1</b> = Individual <b>2</b> = Corporation <b>3</b> = Government	1
senderPhone	<i>String</i>	<i>O</i>	20	Source Customer Phone	080901020304

<b>Parameter</b>	<b>Data Type</b>	<b>Mandatory</b>	<b>Length</b>	<b>Description</b>	<b>Example</b>
sourceAccount No	String	M	19	Source Account Number	8888010001 57508
originatorInfos	Array of Objects	C		The Originator Customer Account Details  To be filled if there is a request from the sender or if the consent from sender has been granted. This is subject to Article 8 paragraph 5 of Law No. 3 of 2011 concerning Fund Transfers. Also check for other provisions, such as the PPAK regulation.	
originatorCusto merNo	String	M	34	Originator customer account number	3330100000 3301
originatorCusto merName	String	M	100	Originator customer account name	lin
originatorBank Code	String	M	8	Originator Bank Code	013
transactionDate	String	M	25	Format transaction date: (ISO 8601) YYYY-MM- DDThh:mm:ss	2019-07- 03T12:08:56 +07:00

<b>Parameter</b>	<b>Data Type</b>	<b>Mandatory</b>	<b>Length</b>	<b>Description</b>	<b>Example</b>
additionalInfo	Object	O	N/A	Additional information for custom use that are not provided by SNAP	{ "deviceId": "12345679237", "channel": "mobilephone"}

### Response Body

<b>Parameter</b>	<b>Data Type</b>	<b>Mandatory</b>	<b>Length</b>	<b>Description</b>	<b>Example</b>
responseCode	String	M	7	Response code	2002300
responseMessage	String	M	150	Response description	Successful
referenceNo	String	C	64	Transaction identifier on service provider system. Must be filled upon successful transaction	2020102977 7700000000 09
partnerReferenceNo	String	O	64	Transaction identifier on service consumer system	2020102900 0000000000 01
amount	Object	O			

<b>Parameter</b>	<b>Data Type</b>	<b>Mandatory</b>	<b>Length</b>	<b>Description</b>	<b>Example</b>
value	String	M	16,2	Net amount of the transaction. If it's IDR then value includes 2 decimal digits. e.g. IDR 10.000,- will be placed with 10000.00	12345678.00
currency	String	M	3	Currency (ISO 4217)	IDR
beneficiaryAccountName	String	M	100	Beneficiary Account Name	Yories Yolanda
beneficiaryAccountNo	String	M	34	Beneficiary Account	888801000003301
beneficiaryAccountType	String	O	1	Beneficiary Account Type <b>D</b> = Current Account <b>S</b> = Saving Account	D
beneficiaryBankCode	String	O	8	Beneficiary Bank Code	002
currency	String	O	3	Currency Type	IDR

<b>Parameter</b>	<b>Data Type</b>	<b>Mandatory</b>	<b>Length</b>	<b>Description</b>	<b>Example</b>
customerReference	String	O	30	Reference Number / No Referral / Transaction ID	10052019
sourceAccountNo	String	M	19	Source Account Number	8888010001 57508
originatorInfos	Array of Objects	C		The Originator Customer Account Details  To be filled if there is a request from the sender or if the consent from sender has been granted. This is subject to Article 8 paragraph 5 of Law No. 3 of 2011 concerning Fund Transfers. Also check for other provisions, such as the PPATK regulation.	
originatorCustomerNo	String	M	34	Originator customer account number	3330100000 3301
originatorCustomerName	String	M	100	Originator customer account name	Iin
originatorBankCode	String	M	8	Originator Bank Code	013
traceNo	String	O	16	Number for tracking to	10052019



<b>Parameter</b>	<b>Data Type</b>	<b>Mandatory</b>	<b>Length</b>	<b>Description</b>	<b>Example</b>
				destination bank	
transactionDate	String	M	25	Format date: (ISO 8601) YYYY-MM-DDThh:mm:ss	2019-07-03T12:08:56+07:00
transactionStatus	String	M	2	<b>00</b> = Success <b>01</b> = Initiated <b>02</b> = Paying <b>03</b> = Pending <b>04</b> = Refunded <b>05</b> = Canceled <b>06</b> = Failed <b>07</b> = Not found	00
transactionStatusDesc	String	O	50	Description status transaction	Success
additionalInfo	Object	O	N/A	Additional information for custom use that are not provided by SNAP	{ "deviceId": "12345679237", "channel": "mobilephone"}

### Contoh Request

```

POST .../v1.0/transfer-skn HTTP/1.2
Content-type: application/json
Authorization: Bearer
gp9HjjEj813Y9JGoqwOeOPWbnt4CUpvIJbU1mMU4a11MNDZ7Sg5u9a"
Authorization-Customer: Bearer
fa8sjjEj813Y9JGoqwOeOPWbnt4CUpvIJbU1mMU4a11MNDZ7Sg5u9a"
X-TIMESTAMP: 2020-12-21T14:36:11+07:00
X-SIGNATURE:
85be817c55b2c135157c7e89f52499bf0c25ad6eebe04a986e8c86256
1b19a5

```

ORIGIN: www.hostname.com  
X-PARTNER-ID: 82150823919040624621823174737537  
X-EXTERNAL-ID: 41807553358950093184162180797837  
X-IP-ADDRESS: 172.24.281.24  
X-DEVICE-ID: 09864ADCASA  
X-LATITUDE: -6.1617169  
X-LONGITUDE: 106.6643946  
CHANNEL-ID: 95221

```
{
  "partnerReferenceNo":"2020102900000000000001",
  "amount":{
    "value":"12345678.00",
    "currency":"IDR"
  },
  "beneficiaryAccountName":"Yories Yolanda",
  "beneficiaryAccountNo":"888801000157508",
  "beneficiaryAddress":"Palembang",
  "beneficiaryBankCode":"002",
  "beneficiaryBankName":"Bank BRI",
  "beneficiaryCustomerResidence":"1",
  "beneficiaryCustomerType":"1",
  "beneficiaryEmail":"yories.yolanda@work.bri.co.id",
  "currency":"IDR",
  "customerReference":"10052019",
  "feeType":"BEN",
  "kodepos":"12250",
  "receiverPhone":"080901020304",
  "remark":"remark test",
  "senderCustomerResidence":"1",
  "senderCustomerType":"1",
  "senderPhone":"080901020304",
  "sourceAccountNo":"888801000157508",
  "originatorInfos":[{
    "originatorCustomerNo":"33301000003301",
    "originatorCustomerName":"Iin"
    "originatorBankCode":"013"
  },
  {
    "originatorCustomerNo":"33301000003302",
    "originatorCustomerName":"Renaldy"
    "originatorBankCode":"022"
  },
  {
    "originatorCustomerNo":"33301000003303",
    "originatorCustomerName":"Aufar"
    "originatorBankCode":"008"
  }
],
  "transactionDate":"2019-07-03T12:08:56+07:00",
  "additionalInfo":{
    "deviceId":"12345679237",
```

```
    "channel": "mobilephone"
  }
}
```

### Contoh Response

Content-type: application/json

X-TIMESTAMP: 2020-12-21T14:36:19+07:00

```
{
  "responseCode": "2002300",
  "responseMessage": "Successful",
  "referenceNo": "2020102977770000000009",
  "partnerReferenceNo": "2020102900000000000001",
  "amount": {
    "value": "12345678.00",
    "currency": "IDR"
  },
  "beneficiaryAccountName": "Yories Yolanda",
  "beneficiaryAccountNo": "888801000003301",
  "beneficiaryAccountType": "D",
  "beneficiaryBankCode": "002",
  "currency": "IDR",
  "customerReference": "10052019",
  "sourceAccountNo": "888801000157508",
  "originatorInfos": [{
    "originatorCustomerNo": "33301000003301",
    "originatorCustomerName": "Iin",
    "originatorBankCode": "013"
  },
  {
    "originatorCustomerNo": "33301000003302",
    "originatorCustomerName": "Renaldy",
    "originatorBankCode": "022"
  },
  {
    "originatorCustomerNo": "33301000003303",
    "originatorCustomerName": "Aufar",
    "originatorBankCode": "008"
  }
],
  "traceNo": "10052019",
  "transactionDate": "2019-07-03T12:08:56+07:00",
  "transactionStatus": "00",
  "transactionStatusDesc": "success",
  "additionalInfo": {
    "deviceId": "12345679237",
    "channel": "mobilephone"
  }
}
```

## b. Notify SKNBI

### Informasi Umum

<b>Service Code</b>	75
<b>Name</b>	API SKNBI Notification
<b>Version</b>	1.0
<b>HTTP Method</b>	POST
<b>Path</b>	.../{version}/transfer-skn/notify

### Request Body

<b>Parameter</b>	<b>Data Type</b>	<b>Mandatory</b>	<b>Length</b>	<b>Description</b>	<b>Example</b>
originalPartnerReferenceNo	String	O	64	Original transaction identifier on service consumer system	2020102900 0000000000 01
originalReferenceNo	String	O	64	Original transaction identifier on service provider system	2020102977 7700000000 09
originalExternalId	String	O	19	Original Customer Reference Number	10052019
latestTransactionStatus	String	M	2	<b>00</b> = Success <b>01</b> = Initiated <b>02</b> = Paying <b>03</b> = Pending <b>04</b> = Refunded <b>05</b> = Canceled	00

<b>Parameter</b>	<b>Data Type</b>	<b>Mandatory</b>	<b>Length</b>	<b>Description</b>	<b>Example</b>
				<b>06</b> = Failed <b>07</b> = Not found	
amount	Object	O			
value	String	M	16,2	Net amount of the transaction. If it's IDR then value includes 2 decimal digits. e.g. IDR 10.000,- will be placed with 10000.00	10000.00
currency	String	M	3	Currency (ISO 4217)	IDR
beneficiaryAccountName	String	M	100	Beneficiary Account Name	Yories Yolanda
beneficiaryAccountNo	String	M	34	Beneficiary Account	888801000003301
beneficiaryBankCode	String	M	8	Beneficiary Bank Code	002
sourceAccountNo	String	M	19	Beneficiary Bank Code	888801000157508
transactionDate	String	M	25	Format transaction	2020-12-21T14:06:21

<b>Parameter</b>	<b>Data Type</b>	<b>Mandatory</b>	<b>Length</b>	<b>Description</b>	<b>Example</b>
				date: (ISO 8601) YYYY-MM-DDThh:mm:ss	+07:00
additionalInfo	Object	O	N/A	Additional information for custom use that are not provided by SNAP	{"deviceId": "12345679237", "channel": "mobilephone"}

### Response Body

<b>ParamSeter</b>	<b>Data Type</b>	<b>Mandatory</b>	<b>Length</b>	<b>Description</b>	<b>Example</b>
responseCode	String	M	7	Response code	2007500
responseMessage	String	M	150	Response description	Successful

### Contoh Request

```

POST .../v1.0/transfer-skn/notify HTTP/1.2
Content-type: application/json
Authorization: Bearer
gp9HjjEj813Y9JGoqwOeOPWbnt4CUpvIJbU1mMU4a11MNDZ7Sg5u9a"
Authorization-Customer: Bearer
fa8sjjEj813Y9JGoqwOeOPWbnt4CUpvIJbU1mMU4a11MNDZ7Sg5u9a"
X-TIMESTAMP: 2020-12-22T07:53:16+07:00
X-SIGNATURE:
85be817c55b2c135157c7e89f52499bf0c25ad6eebe04a986e8c86256
1b19a5
ORIGIN: www.hostname.com
X-PARTNER-ID: 82150823919040624621823174737537
X-EXTERNAL-ID: 41807553358950093184162180797837
X-IP-ADDRESS: 172.24.281.24
X-DEVICE-ID: 09864ADCASA
X-LATITUDE: -6.1617169

```

```
X-LONGITUDE: 106.6643946
CHANNEL-ID: 95221
{
  "originalPartnerReferenceNo":"202010290000000000000001",
  "originalReferenceNo":"202010297777000000000009",
  "originalExternalId":"10052019",
  "latestTransactionStatus":"00",
  "amount":{
    "value":"10000.00",
    "currency":"IDR"
  },
  "beneficiaryAccountName":"Yories Yolanda",
  "beneficiaryAccountNo":"888801000003301",
  "beneficiaryBankCode":"002",
  "sourceAccountNo":"888801000157508",
  "transactionDate":"2020-12-21T14:06:21+07:00",
  "additionalInfo":{
    "deviceId":"12345679237",
    "channel":"mobilephone"
  }
}
```

### Contoh Response

```
Content-type: application/json
X-TIMESTAMP: 2020-12-22T07:53:21+07:00

{
  "responseCode":"2007500",
  "responseMessage":"Successful"
}
```

## 4.2.2.7. Virtual Account Sequence Diagram

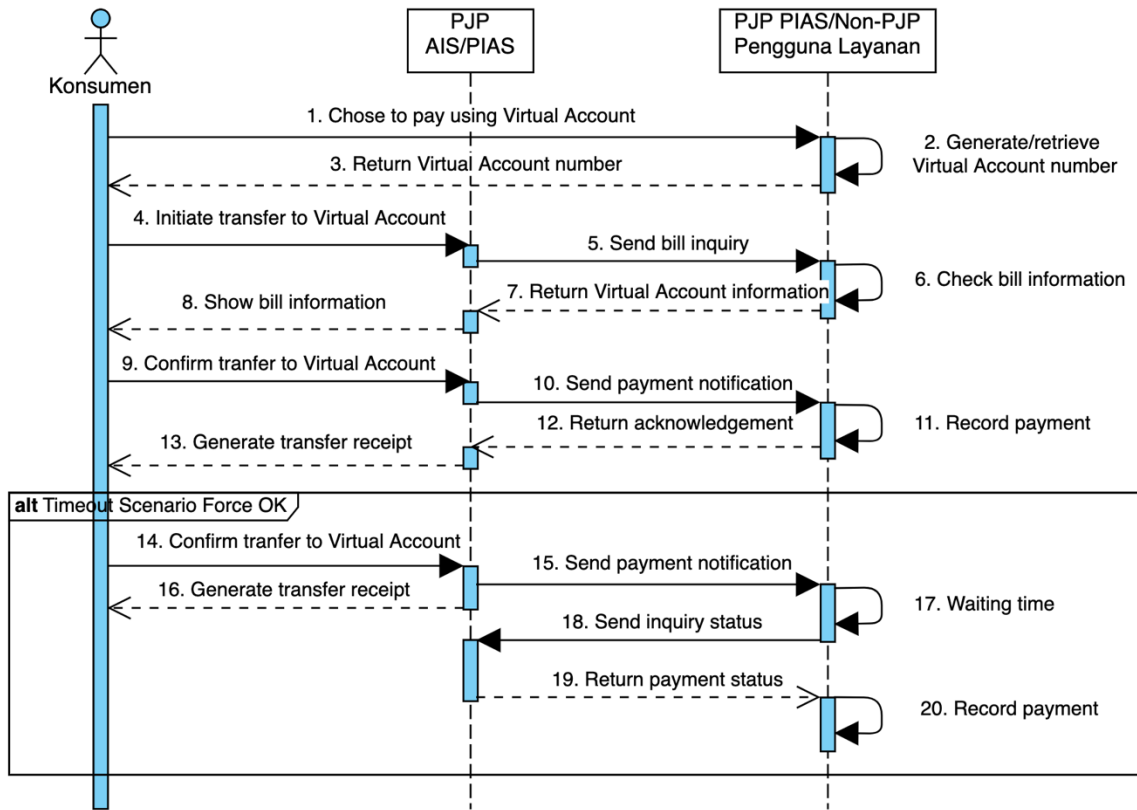

Sequence Diagram Inquiry Payment – Virtual Account



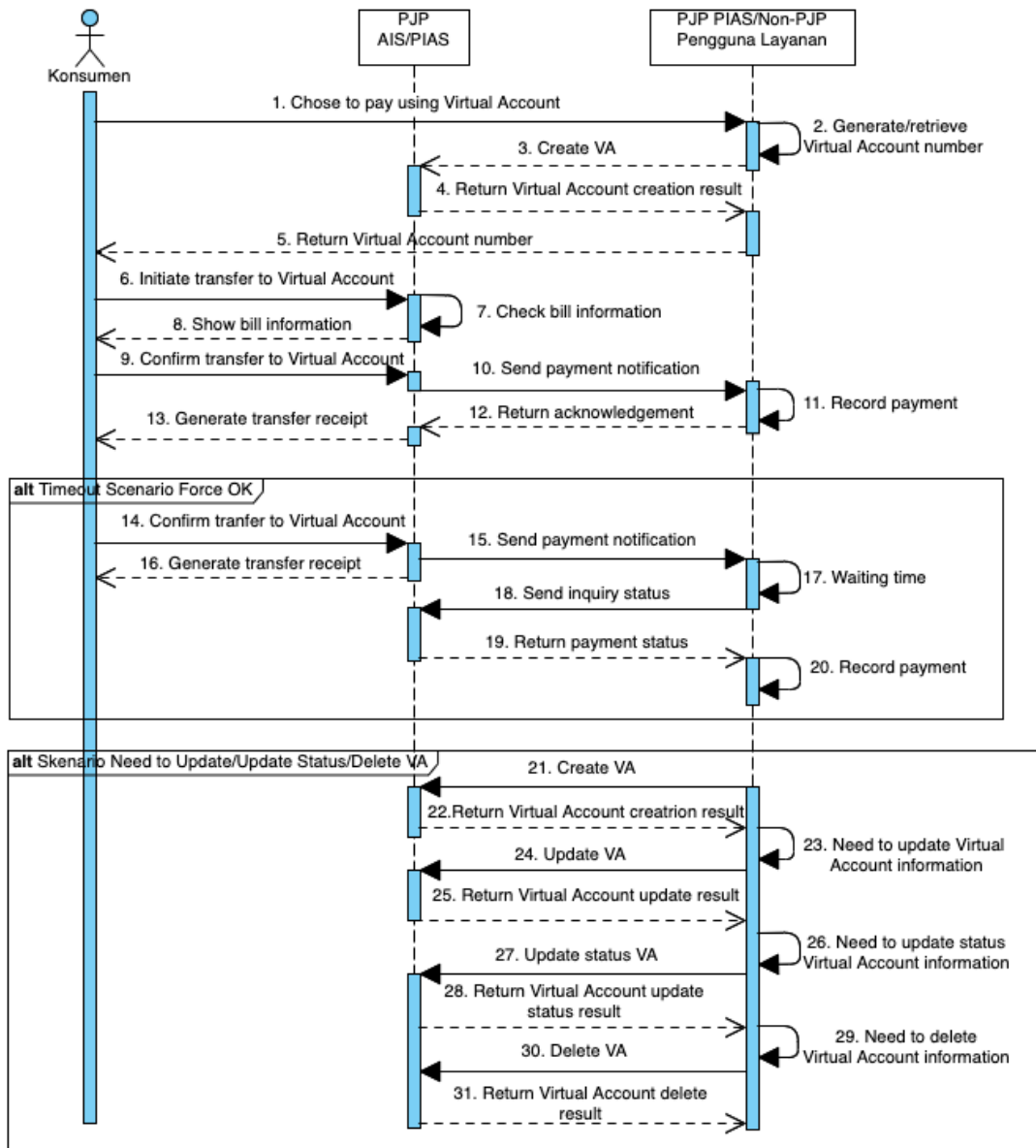

Sequence Diagram Create Virtual Account

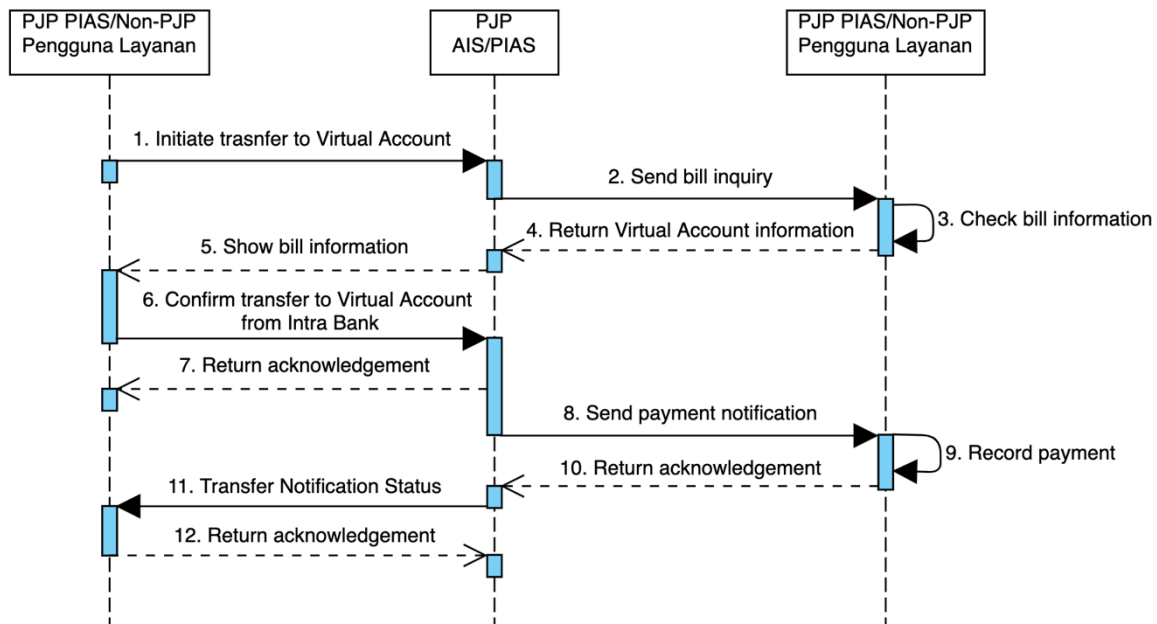

Fund Transfer to Virtual Account

### a. Inquiry

#### Informasi Umum

<b>Service Code</b>	24
<b>Name</b>	API Virtual Account - Inquiry
<b>Version</b>	1.0
<b>HTTP Method</b>	POST
<b>Path</b>	.../{version}/transfer-va/inquiry

#### Request Body

<b>Parameter</b>	<b>Data Type</b>	<b>Mandatory</b>	<b>Length</b>	<b>Description</b>	<b>Example</b>
partnerServiceId	String	M	8	Derivative of X-PARTNER-ID, similar to company code, 8 digit left padding space.	" 088899"

<b>Parameter</b>	<b>Data Type</b>	<b>Mandatory</b>	<b>Length</b>	<b>Description</b>	<b>Example</b>
customerNo	<i>String</i>	M	20	Unique number (up to 20 digits).	“1234567890 1234567890”
virtualAccount No	<i>String</i>	M	28	partnerServiceId (8 digit left padding space) + customerNo (up to 20 digits) or virtualAccountNo	“ 08889912345 67890123456 7890”
trxDateInit	<i>Date</i>	O	25	PJP internal system datetime with timezone, which follows the ISO-8601 standard	20201231T23 5959Z
channelCode	<i>Number</i>	O	4	Channel code based on ISO 18245	6011
language	<i>String</i>	O	2	Language code based on ISO 639-1	ID
amount	<i>Object</i>	O			
value	<i>String</i>	M	16,2	Transaction Amount. Nominal inputted by Customer	12345678.00

<b>Parameter</b>	<b>Data Type</b>	<b>Mandatory</b>	<b>Length</b>	<b>Description</b>	<b>Example</b>
				with 2 decimal	
currency	String	M	3	Currency (ISO 4217)	IDR
hashedSourceAccountNo	String	C	32	<p>Source account number in hash</p> <p>To be filled without hash if there is a request from the sender/payer or if the consent from sender/payer has been granted. This is subject to Article 8 paragraph 5 of Law No. 3 of 2011 concerning Fund Transfers. Also check for other provisions, such as the PPAATK regulation.</p>	<p>abcdefghijklm nopqrstuvwxyz z123456</p>
sourceBankCode	String	C	3	<p>Source account bank code</p> <p>To be filled if there is a request from the sender/payer or if the consent from</p>	008

<b>Parameter</b>	<b>Data Type</b>	<b>Mandatory</b>	<b>Length</b>	<b>Description</b>	<b>Example</b>
				sender/payer has been granted. This is subject to Article 8 paragraph 5 of Law No. 3 of 2011 concerning Fund Transfers. Also check for other provisions, such as the PPATK regulation.	
passApp	String	O	64	Key for 3rd party to access API like client secret	abcdefghijklmn opqrstuvwxyz
inquiryRequestId	String	M	128	Unique identifier for this Inquiry. Generated by PJP.	abcdef- 123456- abcdef
additionalInfo	Object	O	N/A	Additional information for custom use that are not provided by SNAP	{"deviceId": "12345679237", "channel": "mobilephone"}

### Response Body

<b>Parameter</b>	<b>Data Type</b>	<b>Mandatory</b>	<b>Length</b>	<b>Description</b>	<b>Example</b>
responseCode	String	M	7	Response Code	2002400

<b>Parameter</b>	<b>Data Type</b>	<b>Mandatory</b>	<b>Length</b>	<b>Description</b>	<b>Example</b>
responseMessage	String	M	150	Response Description	Success
virtualAccount Data	Object	M			
inquiryStatus	String	O	2	Status of inquiry	00
inquiryReason	Object	O		Reason for Inquiry in multiple language	
english	String	O	64	Reason for Inquiry in English	Success
indonesia	String	O	64	Reason for Inquiry in Bahasa	Sukses
partnerServiceId	String	M	8	Derivative of X-PARTNER-ID, similar to company code, 8 digit left padding space.	“ 088899”
customerNo	String	M	20	Unique number (up to 20 digits).	“1234567890 1234567890”
virtualAccount No	String	M	28	partnerServiceId (8 digit left padding space) + customerNo (up to 20	“ 08889912345 67890123456 7890”

<b>Parameter</b>	<b>Data Type</b>	<b>Mandatory</b>	<b>Length</b>	<b>Description</b>	<b>Example</b>
				digits) or virtualAccountNo	
virtualAccount Name	String	M	255	Customer name	Jokul Doe
virtualAccount Email	String	O	255	Customer email	john@email.com
virtualAccount Phone	String	O	30	Customer's phone number Format: 62xxxxxxxxxx xxxx	62818283848 58
inquiryRequestId	String	M	128	From Inquiry Request	abcdef- 123456- abcdef
totalAmount	Object	O			
value	String	M	16,2	Transaction Amount. Total Amount with 2 decimal	12345678.00
currency	String	M	3	Currency (ISO4217)	IDR
subCompany	String	O	5	Sub Company code generated by Partner	12345

<b>Parameter</b>	<b>Data Type</b>	<b>Mandatory</b>	<b>Length</b>	<b>Description</b>	<b>Example</b>
billDetails	Array of Objects	O		Array with maximum 24 Objects	
billCode	String	O	2	Bill code for Customer choose	01
billNo	String	O	18	Bill number from Partner	123456789012345678
billName	String	O	20	Bill Name	Bill A for Jan
billShortName	String	O	10	Bill Name to shown to	Bill A
billDescription	Object	O		Bill Description	
english	String	O	18	Bill Description in English	Maintenance
indonesia	String	O	18	Bill Description in Bahasa	Pemeliharaan
billSubCompany	String	C	5	Partner's product code. Mandatory if subCompany sent	00001
billAmount	Object	O			
value	String	M	16,2	Billing Amount with 2 decimal digits	12345678.00
currency	String	M	3	Currency (ISO 4217)	IDR



<b>Parameter</b>	<b>Data Type</b>	<b>Mandatory</b>	<b>Length</b>	<b>Description</b>	<b>Example</b>
billAmountLabel	String	O	25	Label for billAmount	Total Tagihan
billAmountValue	String	O	25	Value that will be shown for billAmount	Rp. 50.000,-
additionalInfo	Object	O	N/A	Additional Information for custom use for each bill	
freeTexts	Array of Objects	O		Array with maximum 25 Objects	
english	String	O	32	Will be shown in Channel	Free text
indonesia	String	O	32	Will be shown in Channel	Tulisan bebas
virtualAccount TrxType	String	O	1	Type of Virtual Account  <b>C</b> = Closed Payment <b>O</b> = Open Payment <b>I</b> = Partial <b>M</b> = Minimum - only can be paid once with	C

<b>Parameter</b>	<b>Data Type</b>	<b>Mandatory</b>	<b>Length</b>	<b>Description</b>	<b>Example</b>
				minimum amount <b>L</b> = Maximum <b>N</b> = Open Minimum - can be paid multiple with minimum amount <b>X</b> = Open Maximum - can be paid multiple with cumulative maximum amount) <b>V</b> = Bill Variable <b>W</b> = Multi Bill Variable	
feeAmount	Object	O			
value	String	M	16,2	Transaction Amount.  Nominal inputted by Customer with 2 decimal	12345678.00
currency	String	M	3	Currency (ISO 4217)	IDR
additionalInfo	Object	O	N/A	Additional information for custom use that are not provided by SNAP	<pre>{   "deviceId": "12345679237",   "channel": "mobilephone" }</pre>

## Contoh Request

```
POST .../v1.0/transfer-va/inquiry HTTP/1.2
Content-type: application/json
Authorization: Bearer
gp9HjjEj813Y9JGoqwOeOPWbnt4CUpvIJbU1mMU4a11MNDZ7Sg5u9a"
Authorization-Customer: Bearer
fa8sjjEj813Y9JGoqwOeOPWbnt4CUpvIJbU1mMU4a11MNDZ7Sg5u9a"
X-TIMESTAMP: 2020-12-21T14:56:11+07:00
X-SIGNATURE:
85be817c55b2c135157c7e89f52499bf0c25ad6eebe04a986e8c86256
1b19a5
X-ORIGIN: www.hostname.com
X-PARTNER-ID: 82150823919040624621823174737537
X-EXTERNAL-ID: 41807553358950093184162180797837
X-IP-ADDRESS: 172.24.281.24
X-DEVICE-ID: 09864ADCASA
X-LATITUDE: -6.1617169
X-LONGITUDE: 106.6643946
CHANNEL-ID: 95221
```

```
{
  "partnerServiceId": " 88899",
  "customerNo": "12345678901234567890",
  "virtualAccountNo": " 08889912345678901234567890",
  "txnDateInit": "20201231T235959Z",
  "channelCode": 6011,
  "language": "ID",
  "amount": {
    "value": "12345678.00",
    "currency": "IDR"
  },
  "hashedSourceAccountNo": "abcdefghijklmnopqrstuvwxy1234
56",
  "sourceBankCode": "008",
  "passApp": "abcdefghijklmnopqrstuvwxy",
  "inquiryRequestId": "abcdef-123456-abcdef",
  "additionalInfo": {
    "deviceId": "12345679237",
    "channel": "mobilephone"
  }
}
```

## Contoh Response

```
Content-type: application/json
X-TIMESTAMP: 2020-12-21T14:36:19+07:00
```

```
{
  "responseCode": "2002400",
```

```

"responseMessage": "Success",
"virtualAccountData": {
  "inquiryStatus": "00",
  "inquiryReason": {
    "english": "Success",
    "indonesia": "Sukses"
  },
  "partnerServiceId": " 088899",
  "customerNo": "12345678901234567890",
  "virtualAccountNo": " 08889912345678901234567890",
  "virtualAccountName": "Jokul Doe",
  "virtualAccountEmail": "john@email.com",
  "virtualAccountPhone": "6281828384858",
  "inquiryRequestId": "abcdef-123456-abcdef",
  "totalAmount": {
    "value": "12345678.00",
    "currency": "IDR"
  },
  "subCompany": "12345",
  "billDetails": [
    {
      "billCode": "01",
      "billNo": "123456789012345678",
      "billName": "Bill A for Jan",
      "billShortName": "Bill A",
      "billDescription": {
        "english": "Maintenance",
        "indonesia": "Pemeliharaan"
      },
      "billSubCompany": "00001",
      "billAmount": {
        "value": "12345678.00",
        "currency": "IDR"
      },
      "billAmountLabel": "Total Tagihan",
      "billAmountValue": "Rp. 50.000,-",
      "additionalInfo": {
      }
    }
  ],
  "freeTexts": [
    {
      "english": "Free text",
      "indonesia": "Tulisan bebas"
    }
  ],
  "virtualAccountTrxType": "C",
  "feeAmount": {
    "value": "12345678.00",
    "currency": "IDR"
  }

```

```
    }  
  },  
  "additionalInfo":{  
    "deviceId":"12345679237",  
    "channel":"mobilephone"  
  }  
}
```

## b. Payment

### Informasi Umum

<b>Service Code</b>	25
<b>Name</b>	API Virtual Account - Payment
<b>Version</b>	1.0
<b>HTTP Method</b>	POST
<b>Path</b>	.../{version}/transfer-va/payment

### Request Body

<b>Parameter</b>	<b>Data Type</b>	<b>Mandatory</b>	<b>Length</b>	<b>Description</b>	<b>Example</b>
partnerServiceId	String	M	8	Derivative of X-PARTNER-ID, similar to company code, 8 digit left padding space.	“ 088899”
customerNo	String	M	20	Unique number (up to 20 digits).	“12345678901234567890”
virtualAccountNo	String	M	28	partnerServiceId (8 digit left padding space) + customerNo (up to 20 digits) or virtualAccountNo	“08889912345678901234567890”
virtualAccountName	String	O	255	Customer name	Jokul Doe
virtualAccountEmail	String	O	255	Customer email	jokul@email.com

<b>Parameter</b>	<b>Data Type</b>	<b>Mandatory</b>	<b>Length</b>	<b>Description</b>	<b>Example</b>
virtualAccount Phone	<i>String</i>	O	30	Customer's phone number Format: 62xxxxxxxxxx xxxx	6281828384 858
trxId	<i>String</i>	C	64	Unique identifier generated by Partner.  Must be filled if Payment comes from the Create VA Request	abcdefgh1234
paymentRequestId	<i>String</i>	M	128	Unique identifier generated by PJP. If Payment comes from the Inquiry process, this value must be the same with inquiryReque stId.	abcdef- 123456- abcdef

<b>Parameter</b>	<b>Data Type</b>	<b>Mandatory</b>	<b>Length</b>	<b>Description</b>	<b>Example</b>
channelCode	Number	O	4	Channel code based on ISO 18245	6011
hashedSourceAccountNo	String	C	32	Source account number in hash  To be filled without hash if there is a request from the sender/payer or if the consent from sender/payer has been granted. This is subject to Article 8 paragraph 5 of Law No. 3 of 2011 concerning Fund Transfers. Also check for other provisions, such as the PPAK regulation.	abcdefghijkl mnopqrstuv wxyz123456
sourceBankCode	String	C	3	Source account bank code  To be filled if there is a request from the sender/payer or if the consent from sender/payer has been granted.	008



<b>Parameter</b>	<b>Data Type</b>	<b>Mandatory</b>	<b>Length</b>	<b>Description</b>	<b>Example</b>
				This is subject to Article 8 paragraph 5 of Law No. 3 of 2011 concerning Fund Transfers. Also check for other provisions, such as the PPAK regulation.	
paidAmount	Object	M			
value	String	M	16,2	Paid Amount with 2 decimal	12345678.00
currency	String	M	3	Currency (ISO 4217)	IDR
cumulativePaymentAmount	Object	O			
value	String	M	16,2	Transaction Amount	12345678.00
currency	String	M	3	Currency (ISO 4217)	IDR
paidBills	String	O	6	Hexadecimal format of binary of flag of paid bills.  If there are 24 bills, and paid bills number 1, 4, 6, and 8, will be written in	95000

<b>Parameter</b>	<b>Data Type</b>	<b>Mandatory</b>	<b>Length</b>	<b>Description</b>	<b>Example</b>
				binary 1001010100 0000000000 0000 and converted to Hexa.	
totalAmount	Object	O			
value	String	M	16,2	Transaction Amount.  Total amount from Inquiry with 2 decimal	12345678.00
currency	String	M	3	Currency (ISO 4217)	IDR
trxDateTime	Date	O	25	PJP internal system datetime with timezone, which follows the ISO-8601 standard	20201231T235959Z
referenceNo	String	O	64	Payment auth code generated by PJP	1234567890 12345
journalNum	String	O	6	Sequence journal number in	123456

<b>Parameter</b>	<b>Data Type</b>	<b>Mandatory</b>	<b>Length</b>	<b>Description</b>	<b>Example</b>
				PJP Core System	
paymentType	String	O	1	Type of payment  <b>1</b> = Cash <b>2</b> = Transfer	1
flagAdvise	String	O	1	Flag to indicate is this a retry notification  <b>Y</b> = Retry notification <b>N</b> = New notification	Y
subCompany	String	O	5	Sub Company code generated by Partner	12345
billDetails	Array of Objects	O		Array with maximum 24 Objects	
billCode	String	O	2	From Inquiry Response	01
billNo	String	O	18	From Inquiry Response	1234567890 12345678
billName	String	O	20	From Inquiry Response	Bill A for Jan

<b>Parameter</b>	<b>Data Type</b>	<b>Mandatory</b>	<b>Length</b>	<b>Description</b>	<b>Example</b>
billShortName	String	O	10	From Inquiry Response	Bill A
billDescription	Object	O		From Inquiry Response	
english	String	O	18	From Inquiry Response	Maintenance
indonesia	String	O	18	From Inquiry Response	Pemeliharaan
billSubCompany	String	O	5	From Inquiry Response	00001
billAmount	Object	O			
value	String	M	16,2	Billing Amount with 2 decimal digits From Inquiry Response	12345678.00
currency	String	M	3	Currency (ISO 4217)	IDR
additionalInfo	Object	O	N/A	From Inquiry Response	
billReferenceNo	Number	O	15	Bill auth code generated by PJP	1234567890 12345
freeTexts	Array of Objects	O		Array with maximum 25 Objects	

<b>Parameter</b>	<b>Data Type</b>	<b>Mandatory</b>	<b>Length</b>	<b>Description</b>	<b>Example</b>
english	String	O	32	Will be shown in Channel	Free text
indonesia	String	O	32	Will be shown in Channel	Tulisan bebas
additionalInfo	Object	O	N/A	Additional information for custom use that are not provided by SNAP	<pre>{"deviceId": "12345679237", "channel": "mobilephone"}</pre>

### Response Body

<b>Parameter</b>	<b>Data Type</b>	<b>Mandatory</b>	<b>Length</b>	<b>Description</b>	<b>Example</b>
responseCode	String	M	7	Response Code	2002500
responseMessage	String	M	150	Response Description	Success
virtualAccountData	Object	M			
paymentFlagReason	Object	O		Reason for Payment Status multi language	
indonesia	String	O	200	Reason for Payment Status in English	Success

<b>Parameter</b>	<b>Data Type</b>	<b>Mandatory</b>	<b>Length</b>	<b>Description</b>	<b>Example</b>
english	String	O	200	Reason for Payment in Bahasa	Sukses
partnerServiceId	String	M	8	Derivative of X-PARTNER-ID, similar to company code, 8 digit left padding space.	“ 088899”
customerNo	String	M	20	Unique number (up to 20 digits).	“12345678901234567890”
virtualAccount No	String	M	28	partnerService Id (8 digit left padding space) + customerNo (up to 20 digits) or virtualAccountNo	“08889912345678901234567890”
virtualAccount Name	String	M	255	Customer name	Jokul Doe
virtualAccount Email	String	O	255	Customer email	jokul@email.com
virtualAccount Phone	String	O	30	Customer’s phone number Format:	6281828384858

<b>Parameter</b>	<b>Data Type</b>	<b>Mandatory</b>	<b>Length</b>	<b>Description</b>	<b>Example</b>
				62xxxxxxxxxxx xxx	
trxId	String	O	32	From Payment Request	abcdefgh1234
paymentRequestId	String	M	128	From Payment Request	abcdef- 123456- abcdef
paidAmount	Object	O			
value	String	M	16,2	Transaction Amount. From Payment Request	12345678.00
currency	String	M	3	Currency (ISO 4217)	IDR
paidBills	String	O	6	From Payment Request	95000
totalAmount	Object	O			
value	String	M	16,2	Transaction Amount. From Payment Request	12345678.00
currency	String	M	3	Currency (ISO 4217)	IDR
trxDateTime	Date	O	25	From Payment Request	20201231T2 35959Z
referenceNo	String	O	15	From Payment Request	1234567890 12345

<b>Parameter</b>	<b>Data Type</b>	<b>Mandatory</b>	<b>Length</b>	<b>Description</b>	<b>Example</b>
journalNum	String	O	6	From Payment Request	123456
paymentType	String	O	1	From Payment Request <b>1</b> = Cash <b>2</b> = Transfer	1
flagAdvise	String	O	1	From Payment Request <b>Y</b> = Retry notification <b>N</b> = New notification	Y
paymentFlagStatus	String	O	2	Status for Payment Flag from Partner <b>00</b> = Success <b>01</b> = Reject <b>02</b> = Timeout	00
billDetails	Array of Objects	O		Array with maximum 24 Objects	
billerReferenceId	String	O	64	From Inquiry Response	1234567890 12345678
billCode	String	O	2	From Inquiry Response	01
billNo	String	O	18	From Inquiry Response	1234567890 12345678



<b>Parameter</b>	<b>Data Type</b>	<b>Mandatory</b>	<b>Length</b>	<b>Description</b>	<b>Example</b>
billName	String	O	20	From Inquiry Response	Bill A for Jan
billShortName	String	O	10	From Inquiry Response	Bill A
billDescription	Object	O		From Inquiry Response	
english	String	O	18	From Inquiry Response	Maintenance
indonesia	String	O	18	From Inquiry Response	Pemeliharaan
billSubCompany	String	O	5	From Inquiry Response	00001
billAmount	Object	O			
value	String	M	16,2	From Inquiry Response	12345678.00
currency	String	M	3	Currency (ISO 4217)	IDR
additionalInfo	Object	O	N/A	From Inquiry Response	
status	String	O	2	Payment status for specific Bill	00
reason	Object	O		Reason for Payment Status for specific Bill multiple language	
english	String	O	64	Reason for Payment	Success

<b>Parameter</b>	<b>Data Type</b>	<b>Mandatory</b>	<b>Length</b>	<b>Description</b>	<b>Example</b>
				Status for specific Bill in English	
indonesia	String	O	64	Reason for Payment Status for specific Bill in Bahasa	Sukses
freeTexts	Array of Objects	O		Array with maximum 25 Objects	
english	String	O	32	Will be shown in Channel	Free text
indonesia	String	O	32	Will be shown in Channel	Tulisan bebas
additionalInfo	Object	O	N/A	Additional information for custom use that are not provided by SNAP	{ "deviceId": "12345679237", "channel": "mobilephone"};

### Contoh Request

```

POST .../v1.0/transfer-va/payment HTTP/1.2
Content-type: application/json
Authorization: Bearer
gp9HjjEj813Y9JGoqwOeOPWbnt4CUpvIJbU1mMU4a11MNDZ7Sg5u9a"
Authorization-Customer: Bearer
fa8sjjEj813Y9JGoqwOeOPWbnt4CUpvIJbU1mMU4a11MNDZ7Sg5u9a"
X-TIMESTAMP: 2020-12-21T14:56:11+07:00
X-SIGNATURE:
85be817c55b2c135157c7e89f52499bf0c25ad6eebe04a986e8c86256
1b19a5
X-ORIGIN: www.hostname.com
X-PARTNER-ID: 82150823919040624621823174737537

```

X-EXTERNAL-ID: 41807553358950093184162180797837  
X-IP-ADDRESS: 172.24.281.24  
X-DEVICE-ID: 09864ADCASA  
X-LATITUDE: -6.1617169  
X-LONGITUDE: 106.6643946  
CHANNEL-ID: 95221

```
{
  "partnerServiceId": " 088899",
  "customerNo": "12345678901234567890",
  "virtualAccountNo": " 08889912345678901234567890",
  "virtualAccountName": "Jokul Doe",
  "virtualAccountEmail": "jokul@email.com",
  "virtualAccountPhone": "6281828384858",
  "trxId": "abcdefgh1234",
  "paymentRequestId": "abcdef-123456-abcdef",
  "channelCode": "6011",

  "hashedSourceAccountNo": "abcdefghijklmnopqrstuvwxy123456",
  "sourceBankCode": "008",
  "paidAmount": {
    "value": "12345678.00",
    "currency": "IDR"
  },
  "cumulativePaymentAmount": {
    "value": "12345678.00",
    "currency": "IDR"
  },
  "paidBills": "95000",
  "totalAmount": {
    "value": "12345678.00",
    "currency": "IDR"
  },
  "trxDateTime": "20201231T235959Z",
  "referenceNo": "123456789012345",
  "journalNum": "123456",
  "paymentType": 1,
  "flagAdvise": "Y",
  "subCompany": "12345",
  "billDetails": [
    {
      "billCode": "01",
      "billNo": "123456789012345678",
      "billName": "Bill A for Jan",
      "billShortName": "Bill A",
      "billDescription": {
        "english": "Maintenance",
        "indonesia": "Pemeliharaan"
      },
      "billSubCompany": "00001",
    }
  ]
}
```

```

        "billAmount":{
            "value":"12345678.00",
            "currency":"IDR"
        },
        "additionalInfo":{

        },
        "billReferenceNo":"123456789012345"
    }
],
"freeTexts":[
    {
        "english":"Free text",
        "indonesia":"Tulisan bebas"
    }
],
"additionalInfo":{
    "deviceId":"12345679237",
    "channel":"mobilephone"
}
}

```

### Contoh Response

Content-type: application/json  
X-TIMESTAMP: 2020-12-21T14:36:19+07:00

```

{
    "responseCode":"2002500",
    "responseMessage":"Success",
    "virtualAccountData":{
        "paymentFlagReason":{
            "english":"Success",
            "indonesia":"Sukses"
        },
        "partnerServiceId":" 088899",
        "customerNo":"12345678901234567890",
        "virtualAccountNo":" 08889912345678901234567890",
        "virtualAccountName":"Jokul Doe",
        "virtualAccountEmail":"jokul@email.com",
        "virtualAccountPhone":"6281828384858",
        "trxId":"abcdefgh1234",
        "paymentRequestId":"abcdef-123456-abcdef",
        "paidAmount":{
            "value":"12345678.00",
            "currency":"IDR"
        },
        "paidBills":"95000",
        "totalAmount":{
            "value":"12345678.00",
            "currency":"IDR"
        }
    }
}

```

```

    },
    "trxDateTime":"20201231T235959Z",
    "referenceNo":"123456789012345",
    "journalNum":"123456",
    "paymentType":1,
    "flagAdvise":"Y",
    "paymentFlagStatus":"00",
    "billDetails":[
      {
        "billerReferenceId":"123456789012345678",
        "billCode":"01",
        "billNo":"123456789012345678",
        "billName":"Bill A for Jan",
        "billShortName":"Bill A",
        "billDescription":{
          "english":"Maintenance",
          "indonesia":"Pemeliharaan"
        },
        "billSubCompany":"00001",
        "billAmount":{
          "value":"12345678.00",
          "currency":"IDR"
        },
        },
        "additionalInfo":{

        },
        "status":"00",
        "reason":{
          "english":"Success",
          "indonesia":"Sukses"
        }
      }
    ],
    "freeTexts":[
      {
        "english":"Free text",
        "indonesia":"Tulisan bebas"
      }
    ]
  },
  "additionalInfo":{
    "deviceId":"12345679237",
    "channel":"mobilephone"
  }
}

```

### c. Inquiry Status

#### Informasi Umum

<b>Service Code</b>	26
<b>Name</b>	API Virtual Account – Inquiry Status
<b>Version</b>	1.0
<b>HTTP Method</b>	POST
<b>Path</b>	.../{version}/transfer-va/status

#### Request Body

<i>Parameter</i>	<i>Data Type</i>	<i>Mandatory</i>	<i>Length</i>	<i>Description</i>	<i>Example</i>
partnerServiceId	String	M	8	Derivative of X-PARTNER-ID , similar to company code, 8 digit left padding space.	“ 088899”
customerNo	String	M	20	Unique number (up to 20 digits).	“12345678901234567890”
virtualAccountNo	String	M	28	partnerServiceId (8 digit left padding space) + customerNo (up to 20 digits).	“08889912345678901234567890”
inquiryRequestId	String	C	128	Unique identifier from Inquiry. For use case Bill stored in	abcdef-123456-abcdef

<b>Parameter</b>	<b>Data Type</b>	<b>Mandatory</b>	<b>Length</b>	<b>Description</b>	<b>Example</b>
				Partner. If not send, will return array of transaction based on virtualAccou ntNo	
paymentRequestId	String	O	128	Unique identifier from Payment was generated by PJP.	abcdef- 123456- abcdef
additionalInfo	Object	O	N/A	Additional information for custom use that are not provided by SNAP	{"deviceId": "12345679237", "channel": "mobilephone"}

### Response Body

<b>Parameter</b>	<b>Data Type</b>	<b>Mandatory</b>	<b>Length</b>	<b>Description</b>	<b>Example</b>
responseCode	String	M	7	Response Code	2002600
responseMessage	String	M	150	Response Description	Success
virtualAccount Data	Object	M			

<b>Parameter</b>	<b>Data Type</b>	<b>Mandatory</b>	<b>Length</b>	<b>Description</b>	<b>Example</b>
paymentFlagReason	Object	O		Reason for Payment Status multi language	
english	String	O	200	Reason for Payment in English	Success
indonesia	String	O	200	Reason for Payment in Bahasa	Sukses
partnerServiceId	String	M	8	Derivative of X-PARTNER-ID, similar to company code, 8 digit left padding space.	“ 088899”
customerNo	String	M	20	Unique number (up to 20 digits).	“12345678901234567890”
virtualAccountNo	String	M	28	partnerServiceId (8 digit left padding space) + customerNo (up to 20 digits) or virtualAccountNo	“08889912345678901234567890”
inquiryRequestId	String	M	128	Unique identifier from Inquiry	abcdef-123456-abcdef



<b>Parameter</b>	<b>Data Type</b>	<b>Mandatory</b>	<b>Length</b>	<b>Description</b>	<b>Example</b>
paymentRequestId	String	C	128	Unique identifier for this Payment from PJP. Mandatory if Payment happened.	abcdef-123456-abcdef
paidAmount	Object	O			
value	String	M	16,2	Paid Amount with 2 decimal	12345678.00
currency	String	M	3	Currency of amount based on ISO 4217	IDR
paidBills	String	O	6	Hexadecimal format of binary of flag of paid bills.  If there are 24 bills, and paid bills number 1, 4, 6, and 8, will be written in binary 10010101000 00000000000 00 and converted to Hexa.	95000

<b>Parameter</b>	<b>Data Type</b>	<b>Mandatory</b>	<b>Length</b>	<b>Description</b>	<b>Example</b>
totalAmount	Object	O			
value	String	M	16,2	Transaction Amount. Total amount from Inquiry with 2 decimal	12345678.00
currency	String	M	3	Currency (ISO4217)	IDR
trxDateTime	Date	O	25	PJP internal system datetime with timezone, which follows the ISO-8601 standard	20201231T235959Z
transactionDate	Date	O	25	Payment datetime when the payment happened	20201230T235959Z
referenceNo	String	O	15	Payment auth code generated by PJP	123456789012345
paymentType	String	O	1	Type of payment <b>1</b> = Cash	1

<b>Parameter</b>	<b>Data Type</b>	<b>Mandatory</b>	<b>Length</b>	<b>Description</b>	<b>Example</b>
				<b>2</b> = Transfer	
flagAdvise	String	O	1	Flag to indicate is this a retry notification  <b>Y</b> = Retry notification <b>N</b> = New notification	Y
paymentFlagStatus	String	O	2	Status for Payment Flag	00
billDetails	Array of Objects	O		Array with maximum 24 Objects	
billCode	String	O	2	Bill code for Customer choose	01
billNo	String	O	18	Bill number from Partner	1234567890 12345678
billName	String	O	20	Bill Name	Bill A for Jan
billShortName	String	O	10	Bill Name to shown to	Bill A
billDescription	Object	O		Bill Description	
english	String	O	18	Bill Description in English	Maintenance

<b>Parameter</b>	<b>Data Type</b>	<b>Mandatory</b>	<b>Length</b>	<b>Description</b>	<b>Example</b>
indonesia	String	O	18	Bill Description in Bahasa	Pemeliharaan
billSubCompany	String	O	5	Partner's product code	00001
billAmount	Object	O			
value	String	M	16,2	Billing Amount with 2 decimal digits	12345678.00
currency	String	M	3	Currency (ISO 4217)	IDR
additionalInfo	Object	O	N/A	Additional Information for custom use for each bill	
billReferenceNo	Number	O	15	Bill auth code generated by PJP	1234567890 12345
status	String	O	2	Payment status for specific Bill	00
reason	Object	O	2	Reason for Payment Status for specific Bill multi language	

<b>Parameter</b>	<b>Data Type</b>	<b>Mandatory</b>	<b>Length</b>	<b>Description</b>	<b>Example</b>
english	String	O	64	Reason for Payment Status for specific Bill in English	Success
indonesia	String	O	64	Reason for Payment Status for specific Bill in Bahasa	Sukses
freeTexts	Array of Objects	O		Array with maximum 25 Objects	
english	String	O	32	Will be shown in Channel	Free text
indonesia	String	O	32	Will be shown in Channel	Tulisan bebas
additionalInfo	Object	O	N/A	Additional information for custom use that are not provided by SNAP	{ "deviceId": "12345679237", "channel": "mobilephone"};

### Contoh Request

```
POST .../v1.0/transfer-va/status HTTP/1.2
Content-type: application/json
Authorization: Bearer
gp9HjjEj813Y9JGoqwOeOPWbnt4CUpvIJbU1mMU4a11MNDZ7Sg5u9a"
Authorization-Customer: Bearer
fa8sjjEj813Y9JGoqwOeOPWbnt4CUpvIJbU1mMU4a11MNDZ7Sg5u9a"
X-TIMESTAMP: 2020-12-21T14:56:11+07:00
```

X-SIGNATURE:  
85be817c55b2c135157c7e89f52499bf0c25ad6eeeb04a986e8c86256  
1b19a5  
X-ORIGIN: www.hostname.com  
X-PARTNER-ID: 82150823919040624621823174737537  
X-EXTERNAL-ID: 41807553358950093184162180797837  
X-IP-ADDRESS: 172.24.281.24  
X-DEVICE-ID: 09864ADCASA  
X-LATITUDE: -6.1617169  
X-LONGITUDE: 106.6643946  
CHANNEL-ID: 95221

```
{
  "partnerServiceId": " 088899",
  "customerNo": "12345678901234567890",
  "virtualAccountNo": " 08889912345678901234567890",
  "inquiryRequestId": "abcdef-123456-abcdef",
  "paymentRequestId": "abcdef-123456-abcdef",
  "additionalInfo": {
  }
}
```

## Contoh Response

Content-type: application/json  
X-TIMESTAMP: 2020-12-21T14:36:19+07:00

```
{
  "responseCode": "2002600",
  "responseMessage": "Success",
  "virtualAccountData": {
    "paymentFlagReason": {
      "english": "Success",
      "indonesia": "Sukses"
    },
    "partnerServiceId": " 088899",
    "customerNo": "12345678901234567890",
    "virtualAccountNo": " 08889912345678901234567890",
    "inquiryRequestId": "abcdef-123456-abcdef",
    "paymentRequestId": "abcdef-123456-abcdef",
    "paidAmount": {
      "value": "12345678.00",
      "currency": "IDR"
    },
    "paidBills": "95000",
    "totalAmount": {
      "value": "12345678.00",
      "currency": "IDR"
    },
    "trxDateTime": "20201231T235959Z",
    "transactionDate": "20201230T235959Z",
  }
}
```

```

"referenceNo":"123456789012345",
"paymentType":1,
"flagAdvise":"Y",
"paymentFlagStatus":"00",
"billDetails":[
  {
    "billCode":"01",
    "billNo":"123456789012345678",
    "billName":"Bill A for Jan",
    "billShortName":"Bill A",
    "billDescription":{
      "english":"Maintenance",
      "indonesia":"Pemeliharaan"
    },
    "billSubCompany":"00001",
    "billAmount":{
      "value":"12345678.00",
      "currency":"IDR"
    },
    "additionalInfo":{
    },
    "billReferenceNo":"123456789012345",
    "status":"00",
    "reason":{
      "english":"Success",
      "indonesia":"Sukses"
    }
  }
],
"freeTexts":[
  {
    "english":"Free text",
    "indonesia":"Tulisan bebas"
  }
]
},
"additionalInfo":{
}
}

```

#### d. Create VA

##### Informasi Umum

<b>Service Code</b>	27
<b>Name</b>	API Virtual Account – Create VA
<b>Version</b>	1.0
<b>HTTP Method</b>	POST
<b>Path</b>	.../{version}/transfer-va/create-va

##### Request Body

<b>Parameter</b>	<b>Data Type</b>	<b>Mandatory</b>	<b>Length</b>	<b>Description</b>	<b>Example</b>
partnerServiceId	String	O	8	Derivative of X-PARTNER-ID, similar to company code, 8 digit left padding space.	“ 088899”
customerNo	String	O	20	Unique number (up to 20 digits).	“12345678901234567890”
virtualAccountNo	String	O	28	partnerServiceId (8 digit left padding space) + customerNo (up to 20 digits) or virtualAccountNo	“08889912345678901234567890”
virtualAccountName	String	M	255	Customer name	Jokul Doe



<b>Parameter</b>	<b>Data Type</b>	<b>Mandatory</b>	<b>Length</b>	<b>Description</b>	<b>Example</b>
virtualAccount Email	<i>String</i>	O	255	Customer email	jokul@email.com
virtualAccount Phone	<i>String</i>	O	30	Customer's phone number Format: 62xxxxxxxxxx xxxx	6281828384 858
trxId	<i>String</i>	M	64	Transaction ID in Partner system	abcdefgh1234
totalAmount	<i>Object</i>	O			
value	<i>String</i>	M	16,2	Transaction Amount.  Total Amount with 2 decimal	12345678.00
currency	<i>String</i>	M	3	Currency (ISO 4217)	IDR
billDetails	<i>Array of Objects</i>	O		Array with maximum 24 Objects	
billCode	<i>String</i>	O	2	Bill code for Customer choose	01
billNo	<i>String</i>	O	18	Bill number from Partner	1234567890 12345678
billName	<i>String</i>	O	20	Bill Name	Bill A for Jan

<b>Parameter</b>	<b>Data Type</b>	<b>Mandatory</b>	<b>Length</b>	<b>Description</b>	<b>Example</b>
billShortName	String	O	10	Bill Name to shown to	Bill A
billDescription	Object	O		Bill Description	
english	String	O	18	Bill Description in English	Maintenance
indonesia	String	O	18	Bill Description in Bahasa	Pemeliharaan
billSubCompany	String	O	5	Partner's product code	00001
billAmount	Object	O			
value	String	M	16,2	Billing Amount with 2 decimal digits	12345678.00
currency	String	M	3	Currency (ISO 4217)	IDR
additionalInfo	Object	O	N/A	Additional Information for custom use for each bill	
freeTexts	Array of Objects	O		Array with maximum 25 Objects	
english	String	O	32	Will be shown in Channel	Free text

<b>Parameter</b>	<b>Data Type</b>	<b>Mandatory</b>	<b>Length</b>	<b>Description</b>	<b>Example</b>
indonesia	String	O	32	Will be shown in Channel	Tulisan bebas
virtualAccount TrxType	String	O	1	Type of Virtual Account <b>C</b> = Closed Payment <b>O</b> = Open Payment <b>I</b> = Partial <b>M</b> = Minimum - only can be paid once with minimum amount <b>L</b> = Maximum <b>N</b> = Open Minimum - can be paid multiple with minimum amount <b>X</b> = Open Maximum - can be paid multiple with cumulative maximum amount) <b>V</b> = Bill Variable <b>W</b> = Multi Bill Variable	C
feeAmount	Object	O			
value	String	M	16,2	Transaction Amount	12345678.00

<b>Parameter</b>	<b>Data Type</b>	<b>Mandatory</b>	<b>Length</b>	<b>Description</b>	<b>Example</b>
				Nominal inputted by Customer with 2 decimal	
currency	String	M	3	Currency (ISO 4217)	IDR
expiredDate	String	O	25	Expiration date for Virtual Account. Format expired date: (ISO-8601) YYYY-MM-DDThh:mm:ss	2020-12-31T23:59:59+07:00
additionalInfo	Object	O	N/A	Additional information for custom use that are not provided by SNAP	{"deviceId": "12345679237", "channel": "mobilephone"}

### Response Body

<b>Parameter</b>	<b>Data Type</b>	<b>Mandatory</b>	<b>Length</b>	<b>Description</b>	<b>Example</b>
responseCode	String	M	7	Response Code	2002700
responseMessage	String	M	150	Response Description	Success

<b>Parameter</b>	<b>Data Type</b>	<b>Mandatory</b>	<b>Length</b>	<b>Description</b>	<b>Example</b>
virtualAccount Data	Object	M			
partnerServiceId	String	M	8	Derivative of X-PARTNER-ID, similar to company code, 8 digit left padding space.	“ 088899”
customerNo	String	M	20	Unique number (up to 20 digits).	“12345678901234567890”
virtualAccount No	String	M	28	partnerServiceId (8 digit left padding space) + customerNo (up to 20 digits) or virtualAccountNo	“08889912345678901234567890”
virtualAccount Name	String	M	255	Customer name	Jokul Doe
virtualAccount Email	String	O	255	Customer email	jokul@email.com
virtualAccount Phone	String	O	30	Customer's phone number Format: 62xxxxxxxxxxxx	6281828384858

<b>Parameter</b>	<b>Data Type</b>	<b>Mandatory</b>	<b>Length</b>	<b>Description</b>	<b>Example</b>
trxId	String	M	32	from Create VA Request	abcdefgh1234
totalAmount	Array of Objects	O			
value	String	M	16,2	Transaction Amount. Total Amount with 2 decimal.	12345678.00
currency	String	M	3	Currency. (ISO 4217)	IDR
billDetails	Array of Objects	O		Array with maximum 24 Objects	
billCode	String	O	2	Bill code for Customer choose	01
billNo	String	O	18	Bill number from Partner	1234567890 12345678
billName	String	O	20	Bill Name	Bill A for Jan
billShortName	String	O	10	Bill Name to shown to	Bill A
billDescription	Object	O		Bill Description	
english	String	O	18	Bill Description in English	Maintenance

<b>Parameter</b>	<b>Data Type</b>	<b>Mandatory</b>	<b>Length</b>	<b>Description</b>	<b>Example</b>
indonesia	String	O	18	Bill Description in Bahasa	Pemeliharaan
billSubCompany	String	O	5	Partner's product code	00001
billAmount	Object	O			
value	String	M	16,2	Billing Amount with 2 decimal digits	12345678.00
currency	String	M	3	Currency (ISO 4217)	IDR
additionalInfo	Object	O	N/A	Additional Information for custom use for each bill	
freeTexts	Array of Objects	O		Array with maximum 25 Objects	
english	String	O	32	Will be shown in Channel	Free text
indonesia	String	O	32	Will be shown in Channel	Tulisan bebas
virtualAccount TrxType	String	O	1	Type of Virtual Account <b>C</b> = Closed Payment	C

<b>Parameter</b>	<b>Data Type</b>	<b>Mandatory</b>	<b>Length</b>	<b>Description</b>	<b>Example</b>
				<b>O</b> = Open Payment <b>I</b> = Partial <b>M</b> = Minimum - only can be paid once with minimum amount <b>L</b> = Maximum <b>N</b> = Open Minimum - can be paid multiple with minimum amount <b>X</b> = Open Maximum - can be paid multiple with cumulative maximum amount) <b>V</b> = Bill Variable <b>W</b> = Multi Bill Variable	
feeAmount	Object	O			
value	String	M	16,2	Transaction Amount.  Nominal inputted by Customer with 2 decimal.	12345678.00
currency	String	M	3	Currency (ISO 4217)	IDR



<b>Parameter</b>	<b>Data Type</b>	<b>Mandatory</b>	<b>Length</b>	<b>Description</b>	<b>Example</b>
expiredDate	String	O	25	Expiration date for Virtual Account. Format date: (ISO 8601) YYYY-MM-DDThh:mm:ss	2020-12-31T23:59:59+07:00
additionalInfo	Object	O	N/A	Additional information for custom use that are not provided by SNAP	{"deviceId": "12345679237", "channel": "mobilephone"}

### Contoh Request

```

POST .../v1.0/transfer-va/create-va HTTP/1.2
Content-type: application/json
Authorization: Bearer
gp9HjjEj813Y9JGoqwOeOPWbnt4CUpvIJbU1mMU4a11MNDZ7Sg5u9a"
Authorization-Customer: Bearer
fa8sjjEj813Y9JGoqwOeOPWbnt4CUpvIJbU1mMU4a11MNDZ7Sg5u9a"
X-TIMESTAMP: 2020-12-21T14:56:11+07:00
X-SIGNATURE:
85be817c55b2c135157c7e89f52499bf0c25ad6eebe04a986e8c86256
1b19a5
X-ORIGIN: www.hostname.com
X-PARTNER-ID: 82150823919040624621823174737537
X-EXTERNAL-ID: 41807553358950093184162180797837
X-IP-ADDRESS: 172.24.281.24
X-DEVICE-ID: 09864ADCASA
X-LATITUDE: -6.1617169
X-LONGITUDE: 106.6643946
CHANNEL-ID: 95221

{
  "partnerServiceId": " 088899",
  "customerNo": "12345678901234567890",
  "virtualAccountNo": " 08889912345678901234567890",
  "virtualAccountName": "Jokul Doe",
  "virtualAccountEmail": "jokul@email.com",

```

```

"virtualAccountPhone":"6281828384858",
"trxId":"abcdefgh1234",
"totalAmount":{
  "value":"12345678.00",
  "currency":"IDR"
},
"billDetails":[
  {
    "billCode":"01",
    "billNo":"123456789012345678",
    "billName":"Bill A for Jan",
    "billShortName":"Bill A",
    "billDescription":{
      "english":"Maintenance",
      "indonesia":"Pemeliharaan"
    },
    "billSubCompany":"00001",
    "billAmount":{
      "value":"12345678.00",
      "currency":"IDR"
    },
    "additionalInfo":{

    }
  }
],
"freeTexts":[
  {
    "english":"Free text",
    "indonesia":"Tulisan bebas"
  }
],
"virtualAccountTrxType":"C",
"feeAmount":{
  "value":"12345678.00",
  "currency":"IDR"
},
"expiredDate":"2020-12-31T23:59:59+07:00",
"additionalInfo":{
  "deviceId":"12345679237",
  "channel":"mobilephone"
}
}

```

### Contoh Response

```

Content-type: application/json
X-TIMESTAMP: 2020-12-21T14:36:19+07:00

```

```

{
  "responseCode":"2002700",

```

```

"responseMessage": "Success",
"virtualAccountData": {
  "partnerServiceId": " 088899",
  "customerNo": "12345678901234567890",
  "virtualAccountNo": " 08889912345678901234567890",
  "virtualAccountName": "Jokul Doe",
  "virtualAccountEmail": "jokul@email.com",
  "virtualAccountPhone": "6281828384858",
  "trxId": "abcdefgh1234",
  "totalAmount": {
    "value": "12345678.00",
    "currency": "IDR"
  },
  "billDetails": [
    {
      "billCode": "01",
      "billNo": "123456789012345678",
      "billName": "Bill A for Jan",
      "billShortName": "Bill A",
      "billDescription": {
        "english": "Maintenance",
        "indonesia": "Pemeliharaan"
      },
      "billSubCompany": "00001",
      "billAmount": {
        "value": "12345678.00",
        "currency": "IDR"
      },
      "additionalInfo": {
      }
    }
  ],
  "freeTexts": [
    {
      "english": "Free text",
      "indonesia": "Tulisan bebas"
    }
  ],
  "virtualAccountTrxType": "C",
  "feeAmount": {
    "value": "12345678.00",
    "currency": "IDR"
  },
  "expiredDate": "2020-12-31T23:59:59+07:00",
  "additionalInfo": {
    "deviceId": "12345679237",
    "channel": "mobilephone"
  }
}
}

```

## e. Update VA

### Informasi Umum

<b>Service Code</b>	28
<b>Name</b>	API Virtual Account – Update VA
<b>Version</b>	1.0
<b>HTTP Method</b>	PUT
<b>Path</b>	.../{version}/transfer-va/update-va

### Request Body

<i>Parameter</i>	<i>Data Type</i>	<i>Mandatory</i>	<i>Length</i>	<i>Description</i>	<i>Example</i>
partnerServiceId	String	M	8	Derivative of X-PARTNER-ID, similar to company code, 8 digit left padding space.	“ 088899”
customerNo	String	M	20	Unique number (up to 20 digits).	“1234567890 1234567890”
virtualAccount No	String	M	28	partnerServiceId (8 digit left padding space) + customerNo (up to 20 digits) or virtualAccountNo	“ 0888991234 5678901234 567890”
virtualAccount Name	String	M	255	Customer name	Jokul Doe
virtualAccount Email	String	O	255	Customer email	jokul@email.com

<b>Parameter</b>	<b>Data Type</b>	<b>Mandatory</b>	<b>Length</b>	<b>Description</b>	<b>Example</b>
virtualAccount Phone	String	O	30	Customer's phone number Format: 62xxxxxxxxxx xxxx	6281828384 858
trxId	String	M	64	Transaction ID in Partner system	abcdefgh1234
totalAmount	Object	O			
value	String	M	16,2	Transaction Amount.  Total Amount with 2 decimal.	12345678.00
currency	String	M	3	Currency. (ISO 4217)	IDR
billDetails	Array of Objects	O		Array with maximum 24 Objects	
billCode	String	O	2	Bill code for Customer choose	01
billNo	String	O	18	Bill number from Partner	1234567890 12345678
billName	String	O	20	Bill Name	Bill A for Jan
billShortName	String	O	10	Bill Name to shown to	Bill A

<b>Parameter</b>	<b>Data Type</b>	<b>Mandatory</b>	<b>Length</b>	<b>Description</b>	<b>Example</b>
billDescription	Object	O		Bill Description	
english	String	O	18	Bill Description in English	Maintenance
indonesia	String	O	18	Bill Description in Bahasa	Pemeliharaan
billSubCompany	String	O	5	Partner's product code	00001
billAmount	Object	O			
value	String	M	16,2	Billing Amount with 2 decimal digits	12345678.00
currency	String	M	3	Currency (ISO 4217)	IDR
additionalInfo	Object	O	N/A	Additional Information for custom use for each bill	
freeTexts	Array of Objects	O		Array with maximum 25 Objects	
english	String	O	32	Will be shown in Channel	Free text

<b>Parameter</b>	<b>Data Type</b>	<b>Mandatory</b>	<b>Length</b>	<b>Description</b>	<b>Example</b>
indonesia	String	O	32	Will be shown in Channel	Tulisan bebas
virtualAccount TrxType	String	O	1	Type of Virtual Account  <b>C</b> = Closed Payment <b>O</b> = Open Payment <b>I</b> = Partial <b>M</b> = Minimum - only can be paid once with minimum amount <b>L</b> = Maximum <b>N</b> = Open Minimum - can be paid multiple with minimum amount <b>X</b> = Open Maximum - can be paid multiple with cumulative maximum amount) <b>V</b> = Bill Variable <b>W</b> = Multi Bill Variable	C
feeAmount	Object	O			
value	String	M	16,2	Transaction Amount.	12345678.00

<b>Parameter</b>	<b>Data Type</b>	<b>Mandatory</b>	<b>Length</b>	<b>Description</b>	<b>Example</b>
				Nominal inputted by Customer with 2 decimal.	
currency	String	M	3	Currency (ISO 4217)	IDR
expiredDate	String	O	25	Expiration date for Virtual Account. Format expired date: (ISO-8601) YYYY-MM-DDThh:mm:ss	2020-12-31T23:59:59+07:00
additionalInfo	Object	O	N/A	Additional information for custom use that are not provided by SNAP	{"deviceId": "12345679237", "channel": "mobilephone"}

### Response Body

<b>Parameter</b>	<b>Data Type</b>	<b>Mandatory</b>	<b>Length</b>	<b>Description</b>	<b>Example</b>
responseCode	String	M	7	Response Code	2002800
responseMessage	String	M	150	Response Description	Success



<b>Parameter</b>	<b>Data Type</b>	<b>Mandatory</b>	<b>Length</b>	<b>Description</b>	<b>Example</b>
virtualAccount Data	Object	M			
partnerServiceId	String	M	8	Derivative of X-PARTNER-ID, similar to company code, 8 digit left padding space.	“ 088899”
customerNo	String	M	20	Unique number (up to 20 digits).	“1234567890 1234567890”
virtualAccount No	String	M	28	partnerServiceId (8 digit left padding space) + customerNo (up to 20 digits) or virtualAccountNo	“ 0888991234 5678901234 567890”
virtualAccount Name	String	M	255	Customer name	Jokul Doe
virtualAccount Email	String	O	255	Customer email	jokul@email.com
virtualAccount Phone	String	O	30	Customer's phone number Format: 62xxxxxxxxxx xxxx	6281828384 858

<b>Parameter</b>	<b>Data Type</b>	<b>Mandatory</b>	<b>Length</b>	<b>Description</b>	<b>Example</b>
trxId	String	M	32	Transaction ID in Partner system	abcdefgh1234
totalAmount	Object	O			
value	String	M	16,2	Transaction Amount. Bill Amount with 2 decimal.	12345678.00
currency	String	M	3	Currency. (ISO 4217)	IDR
billDetails	Array of Objects	O		Array with maximum 24 Objects	
billCode	String	O	2	Bill code for Customer choose	01
billNo	String	O	18	Bill number from Partner	1234567890 12345678
billName	String	O	20	Bill Name	Bill A for Jan
billShortName	String	O	10	Bill Name to shown to	Bill A
billDescription	Object	O		Bill Description	
english	String	O	18	Bill Description in English	Maintenance

<b>Parameter</b>	<b>Data Type</b>	<b>Mandatory</b>	<b>Length</b>	<b>Description</b>	<b>Example</b>
indonesia	String	O	18	Bill Description in Bahasa	Pemeliharaan
billSubCompany	String	O	5	Partner's product code	00001
billAmount	Object	O			
value	String	M	16,2	Billing Amount with 2 decimal digits	12345678.00
currency	String	M	3	Currency (ISO4217)	IDR
additionalInfo	Object	O	N/A	Additional Information for custom use for each bill	
virtualAccount TrxType	String	O	1	Type of Virtual Account  <b>C</b> = Closed Payment <b>O</b> = Open Payment <b>I</b> = Partial <b>M</b> = Minimum - only can be paid once with minimum amount <b>L</b> = Maximum <b>N</b> = Open Minimum - can	C

<b>Parameter</b>	<b>Data Type</b>	<b>Mandatory</b>	<b>Length</b>	<b>Description</b>	<b>Example</b>
				be paid multiple with minimum amount <b>X</b> = Open Maximum - can be paid multiple with cumulative maximum amount) <b>V</b> = Bill Variable <b>W</b> = Multi Bill Variable	
feeAmount	Object	O			
value	String	M	16,2	Transaction Amount.  Nominal inputted by Customer with 2 decimal.	12345678.00
currency	String	M	3	Currency (ISO 4217)	IDR
expiredDate	String	O	25	Expiration date for Virtual Account.  Format expired date: (ISO-8601) YYYY-MM-DDThh:mm:ss	2020-12-31T23:59:59+07:00

<b>Parameter</b>	<b>Data Type</b>	<b>Mandatory</b>	<b>Length</b>	<b>Description</b>	<b>Example</b>
lastUpdateDate	String	O	25	Last update date for Virtual Account.  Format last update date: (ISO-8601) YYYY-MM-DDThh:mm:ss	2020-12-31T23:59:59+07:00
paymentDate	String	O	25	Payment date for Virtual Account.  Format payment date: (ISO-8601) YYYY-MM-DDThh:mm:ss	2020-12-31T23:59:59+07:00
additionalInfo	Object	O	N/A	Additional information for custom use that are not provided by SNAP	{"deviceId": "12345679237", "channel": "mobilephone"}

### Contoh Request

```

PUT .../v1.0/transfer-va/update-va HTTP/1.2
Content-type: application/json
Authorization: Bearer
gp9HjjEj813Y9JGoqwOeOPWbnt4CUpvIJbU1mMU4a11MNDZ7Sg5u9a"
Authorization-Customer: Bearer
fa8sjjEj813Y9JGoqwOeOPWbnt4CUpvIJbU1mMU4a11MNDZ7Sg5u9a"
X-TIMESTAMP: 2020-12-21T14:56:11+07:00
X-SIGNATURE:
85be817c55b2c135157c7e89f52499bf0c25ad6eebe04a986e8c86256
1b19a5

```

```

X-ORIGIN: www.hostname.com
X-PARTNER-ID: 82150823919040624621823174737537
X-EXTERNAL-ID: 41807553358950093184162180797837
X-IP-ADDRESS: 172.24.281.24
X-DEVICE-ID: 09864ADCASA
X-LATITUDE: -6.1617169
X-LONGITUDE: 106.6643946
CHANNEL-ID: 95221
{
  "partnerServiceId": " 088899",
  "customerNo": "12345678901234567890",
  "virtualAccountNo": " 08889912345678901234567890",
  "virtualAccountName": "Jokul Doe",
  "virtualAccountEmail": "jokul@email.com",
  "virtualAccountPhone": "6281828384858",
  "trxId": "abcdefgh1234",
  "totalAmount": {
    "value": "12345678.00",
    "currency": "IDR"
  },
  "billDetails": [
    {
      "billCode": "01",
      "billNo": "123456789012345678",
      "billName": "Bill A for Jan",
      "billShortName": "Bill A",
      "billDescription": {
        "english": "Maintenance",
        "indonesia": "Pemeliharaan"
      },
      "billSubCompany": "00001",
      "billAmount": {
        "value": "12345678.00",
        "currency": "IDR"
      },
      "additionalInfo": {
      }
    }
  ],
  "freeTexts": [
    {
      "english": "Free text",
      "indonesia": "Tulisan bebas"
    }
  ],
  "virtualAccountTrxType": "C",
  "feeAmount": {
    "value": "12345678.00",
    "currency": "IDR"
  },

```

```
"expiredDate":"2020-12-31T23:59:59+07:00",
"additionalInfo":{
  "deviceId":"12345679237",
  "channel":"mobilephone"
}
}
```

## Contoh Response

Content-type: application/json  
X-TIMESTAMP: 2020-12-21T14:36:19+07:00

```
{
  "responseCode":"2002800",
  "responseMessage":"Success",
  "virtualAccountData":{
    "partnerServiceId":" 088899",
    "customerNo":"12345678901234567890",
    "virtualAccountNo":" 08889912345678901234567890",
    "virtualAccountName":"Jokul Doe",
    "virtualAccountEmail":"jokul@email.com",
    "virtualAccountPhone":"6281828384858",
    "trxId":"abcdefgh1234",
    "totalAmount":{
      "value":"12345678.00",
      "currency":"IDR"
    },
    "billDetails":[
      {
        "billCode":"01",
        "billNo":"123456789012345678",
        "billName":"Bill A for Jan",
        "billShortName":"Bill A",
        "billDescription":{
          "english":"Maintenance",
          "indonesia":"Pemeliharaan"
        },
        "billSubCompany":"00001",
        "billAmount":{
          "value":"12345678.00",
          "currency":"IDR"
        },
        "additionalInfo":{
          }
        }
      ],
    "virtualAccountTrxType":"C",
    "feeAmount":{
      "value":"12345678.00",
      "currency":"IDR"
    }
  }
}
```

```
    },
    "expiredDate": "2020-12-31T23:59:59+07:00",
    "lastUpdateDate": "2020-12-31T23:59:59+07:00",
    "paymentDate": "2020-12-31T23:59:59+07:00",
    "additionalInfo": {
      "deviceId": "12345679237",
      "channel": "mobilephone"
    }
  }
}
```



## f. Update Status VA

### Informasi Umum

<b>Service Code</b>	29
<b>Name</b>	API Virtual Account – Update Status VA
<b>Version</b>	1.0
<b>HTTP Method</b>	PUT
<b>Path</b>	.../{version}/transfer-va/update-status

### Request Body

<i>Parameter</i>	<i>Data Type</i>	<i>Mandatory</i>	<i>Length</i>	<i>Description</i>	<i>Example</i>
partnerServiceId	String	M	8	Derivative of X-PARTNER-ID, similar to company code, 8 digit left padding space.	“ 088899”
customerNo	String	M	20	Unique number (up to 20 digits).	“12345678901234567890”
virtualAccountNo	String	M	28	partnerServiceId (8 digit left padding space) + customerNo (up to 20 digits) or virtualAccountNo	“08889912345678901234567890”
trxId	String	M	64	Transaction ID in Partner system	abcdefgh1234
paidStatus	String	M	1	<b>Y</b> = Paid <b>N</b> = Not Paid	Y

## Response Body

<b>Parameter</b>	<b>Data Type</b>	<b>Mandatory</b>	<b>Length</b>	<b>Description</b>	<b>Example</b>
responseCode	String	M	7	Response Code	2002900
responseMessage	String	M	150	Response Description	Success
virtualAccount Data	Object	M			
partnerServiceId	String	M	8	Derivative of X-PARTNER-ID, similar to company code, 8 digit left padding space.	“ 088899”
customerNo	String	M	20	Unique number (up to 20 digits).	“12345678901234567890”
virtualAccount No	String	M	28	partnerServiceId (8 digit left padding space) + customerNo (up to 20 digits) or virtualAccountNo	“08889912345678901234567890”
virtualAccount Name	String	M	255	Customer name	Jokul Doe

<b>Parameter</b>	<b>Data Type</b>	<b>Mandatory</b>	<b>Length</b>	<b>Description</b>	<b>Example</b>
virtualAccount Email	String	O	255	Customer email	jokul@email.com
virtualAccount Phone	String	O	30	Customer's phone number Format: 62xxxxxxxxxx xxxx	6281828384 858
trxId	String	M	64	Transaction ID in Partner system	abcdefgh1234
totalAmount	Object	O			
value	String	M	16,2	Transaction Amount.  Bill Amount with 2 decimal.	12345678.00
currency	String	M	3	Currency. (ISO 4217)	IDR
virtualAccount TrxType	String	O	1	Type of Virtual Account  <b>C</b> = Closed Payment <b>O</b> = Open Payment <b>I</b> = Partial <b>M</b> = Minimum - only can be paid once with	C

<b>Parameter</b>	<b>Data Type</b>	<b>Mandatory</b>	<b>Length</b>	<b>Description</b>	<b>Example</b>
				minimum amount <b>L</b> = Maximum <b>N</b> = Open Minimum - can be paid multiple with minimum amount <b>X</b> = Open Maximum - can be paid multiple with cumulative maximum amount) <b>V</b> = Bill Variable <b>W</b> = Multi Bill Variable	
feeAmount	Object	O			
value	String	M	16,2	Transaction Amount.  Nominal inputted by Customer with 2 decimal.	12345678.00
currency	String	M	3	Currency (ISO 4217)	IDR
expiredDate	String	O	25	Expiration date for Virtual Account.	2020-12-31T23:59:59+07:00

<b>Parameter</b>	<b>Data Type</b>	<b>Mandatory</b>	<b>Length</b>	<b>Description</b>	<b>Example</b>
				Format expired date: (ISO-8601) YYYY-MM-DDThh:mm:ss	
lastUpdateDate	String	O	25	Last update date for Virtual Account. Format last update date: (ISO-8601) YYYY-MM-DDThh:mm:ss	2020-12-31T23:59:59+07:00
paymentDate	String	O	25	Payment date for Virtual Account. Format payment date: (ISO-8601) YYYY-MM-DDThh:mm:ss	2020-12-31T23:59:59+07:00
additionalInfo	Object	O	N/A	Additional information for custom use that are not provided by SNAP	{"deviceId": "12345679237", "channel": "mobilephone"}

### Contoh Request

```
PUT .../v1.0/transfer-va/update-status HTTP/1.2
Content-type: application/json
```

Authorization: Bearer  
gp9HjjEj813Y9JGoqwOeOPWbnt4CUpvIJbU1mMU4a11MNDZ7Sg5u9a"  
Authorization-Customer: Bearer  
fa8sjjEj813Y9JGoqwOeOPWbnt4CUpvIJbU1mMU4a11MNDZ7Sg5u9a"  
X-TIMESTAMP: 2020-12-21T14:56:11+07:00  
X-SIGNATURE:  
85be817c55b2c135157c7e89f52499bf0c25ad6eebe04a986e8c86256  
1b19a5  
X-ORIGIN: www.hostname.com  
X-PARTNER-ID: 82150823919040624621823174737537  
X-EXTERNAL-ID: 41807553358950093184162180797837  
X-IP-ADDRESS: 172.24.281.24  
X-DEVICE-ID: 09864ADCASA  
X-LATITUDE: -6.1617169  
X-LONGITUDE: 106.6643946  
CHANNEL-ID: 95221

```
{  
  "partnerServiceId": " 088899",  
  "customerNo": "12345678901234567890",  
  "virtualAccountNo": " 08889912345678901234567890",  
  "trxId": "abcdefgh1234",  
  "paidStatus": "Y"  
}
```

## Contoh Response

Content-type: application/json  
X-TIMESTAMP: 2020-12-21T14:36:19+07:00

```
{  
  "responseCode": "2002900",  
  "responseMessage": "Success",  
  "virtualAccountData": {  
    "partnerServiceId": " 088899",  
    "customerNo": "12345678901234567890",  
    "virtualAccountNo": " 08889912345678901234567890",  
    "virtualAccountName": "Jokul Doe",  
    "virtualAccountEmail": "jokul@email.com",  
    "virtualAccountPhone": "6281828384858",  
    "trxId": "abcdefgh1234",  
    "totalAmount": {  
      "value": "12345678.00",  
      "currency": "IDR"  
    },  
    "virtualAccountTrxType": "C",  
    "feeAmount": {  
      "value": "12345678.00",  
      "currency": "IDR"  
    },  
    "expiredDate": "2020-12-31T23:59:59+07:00",  
  }  
}
```

```
"lastUpdateDate":"2020-12-31T23:59:59+07:00",
"paymentDate":"2020-12-31T23:59:59+07:00",
"additionalInfo":{
  "deviceId":"12345679237",
  "channel":"mobilephone"
}
}
```

### g. Inquiry VA

#### Informasi Umum

<b>Service Code</b>	30
<b>Name</b>	API Virtual Account – Inquiry VA
<b>Version</b>	1.0
<b>HTTP Method</b>	POST
<b>Path</b>	.../{version}/transfer-va/inquiry-va

#### Request Body

<i>Parameter</i>	<i>Data Type</i>	<i>Mandatory</i>	<i>Length</i>	<i>Description</i>	<i>Example</i>
partnerServiceId	String	M	8	Derivative of X-PARTNER-ID, similar to company code, 8 digit left padding space.	“ 088899”
customerNo	String	M	20	Unique number (up to 20 digits).	“12345678901234567890”
virtualAccountNo	String	M	28	partnerServiceId (8 digit left padding space) + customerNo (up to 20 digits) or virtualAccountNo	“08889912345678901234567890”
trxId	String	M	64	Transaction ID in Partner system	abcdefgh1234



## Response Body

<b>Parameter</b>	<b>Data Type</b>	<b>Mandatory</b>	<b>Length</b>	<b>Description</b>	<b>Example</b>
responseCode	String	M	7	Response Code	2003000
responseMessage	String	M	150	Response Description	Success
virtualAccount Data	Object	M			
partnerServiceId	String	M	8	Derivative of X-PARTNER-ID, similar to company code, 8 digit left padding space.	“ 088899”
customerNo	String	M	20	Unique number (up to 20 digits).	“12345678901234567890”
virtualAccount No	String	M	28	partnerServiceId (8 digit left padding space) + customerNo (up to 20 digits) or virtualAccountNo	“08889912345678901234567890”
virtualAccount Name	String	M	255	Customer name	Jokul Doe
virtualAccount Email	String	O	255	Customer email	jokul@email.com

<b>Parameter</b>	<b>Data Type</b>	<b>Mandatory</b>	<b>Length</b>	<b>Description</b>	<b>Example</b>
virtualAccount Phone	String	O	30	Customer's phone number Format:62xx xxxxxxxxxxxx	6281828384 858
trxId	String	M	32	Transaction ID in Partner system	abcdefgh1234
totalAmount	Object	O			
value	String	M	16,2	Bill Amount with 2 decimal.	12345678.00
currency	String	M	3	Currency. (ISO 4217)	IDR
billDetails	Array of Objects	O		Array with maximum 24 Objects	
billCode	String	O	2	Bill code for Customer choose	01
billNo	String	O	18	Bill number from Partner	1234567890 12345678
billName	String	O	20	Bill Name	Bill A for Jan
billShortName	String	O	10	Bill Name to shown to	Bill A
billDescription	Object	O		Bill Description	

<b>Parameter</b>	<b>Data Type</b>	<b>Mandatory</b>	<b>Length</b>	<b>Description</b>	<b>Example</b>
english	String	O	18	Bill Description in English	Maintenance
indonesia	String	O	18	Bill Description in Bahasa	Pemeliharaan
billSubCompany	String	O	5	Partner's product code	00001
billAmount	Object	O			
value	String	M	16,2	Billing Amount with 2 decimal digits	12345678.00
currency	String	M	3	Currency (ISO 4217)	IDR
additionalInfo	Object	O	N/A	Additional Information for custom use for each bill	
freeTexts	Array of Objects	O		Array with maximum 25 Objects	
english	String	O	32	Will be shown in Channel	Free text
indonesia	String	O	32	Will be shown in Channel	Tulisan bebas

<b>Parameter</b>	<b>Data Type</b>	<b>Mandatory</b>	<b>Length</b>	<b>Description</b>	<b>Example</b>
virtualAccount TrxType	String	O	1	Type of Virtual Account  <b>C</b> = Closed Payment <b>O</b> = Open Payment <b>I</b> = Partial <b>M</b> = Minimum - only can be paid once with minimum amount <b>L</b> = Maximum <b>N</b> = Open Minimum - can be paid multiple with minimum amount <b>X</b> = Open Maximum - can be paid multiple with cumulative maximum amount) <b>V</b> = Bill Variable <b>W</b> = Multi Bill Variable	C
feeAmount	Object	O			
value	String	M	16,2	Transaction Amount.	12345678.00

<b>Parameter</b>	<b>Data Type</b>	<b>Mandatory</b>	<b>Length</b>	<b>Description</b>	<b>Example</b>
				Nominal inputted byCustomer with 2 decimal.	
currency	String	M	3	Currency (ISO 4217)	IDR
expiredDate	String	O	25	Expiration date for Virtual Account. Format expired date: (ISO-8601) YYYY-MM-DDThh:mm:ss	2020-12-31T23:59:59+07:00
lastUpdateDate	String	O	25	Last update date for Virtual Account. Format last update date: (ISO-8601) YYYY-MM-DDThh:mm:ss	2020-12-31T23:59:59+07:00
paymentDate	String	O	25	Payment date for Virtual Account.	2020-12-31T23:59:59+07:00

<b>Parameter</b>	<b>Data Type</b>	<b>Mandatory</b>	<b>Length</b>	<b>Description</b>	<b>Example</b>
				Format payment date: (ISO-8601) YYYY-MM- DDThh:mm:ss	
additionalInfo	Object	O	N/A	Additional information for custom use that are not provided by SNAP	{"deviceId": "12345679237", "channel": "mobilephone"}

### Contoh Request

```

POST .../v1.0/transfer-va/inquiry-va HTTP/1.2
Content-type: application/json
Authorization: Bearer
gp9HjjEj813Y9JGoqwOeOPWbnt4CUpvIJbU1mMU4a11MNDZ7Sg5u9a"
Authorization-Customer: Bearer
fa8sjjEj813Y9JGoqwOeOPWbnt4CUpvIJbU1mMU4a11MNDZ7Sg5u9a"
X-TIMESTAMP: 2020-12-21T14:56:11+07:00
X-SIGNATURE:
85be817c55b2c135157c7e89f52499bf0c25ad6eebe04a986e8c86256
1b19a5
X-ORIGIN: www.hostname.com
X-PARTNER-ID: 82150823919040624621823174737537
X-EXTERNAL-ID: 41807553358950093184162180797837
X-IP-ADDRESS: 172.24.281.24
X-DEVICE-ID: 09864ADCASA
X-LATITUDE: -6.1617169
X-LONGITUDE: 106.6643946
CHANNEL-ID: 95221

{
  "partnerServiceId": " 088899",
  "customerNo": "12345678901234567890",
  "virtualAccountNo": " 08889912345678901234567890",
  "trxId": "abcdefgh1234"
}

```

### Contoh Response

```

Content-type: application/json

```

X-TIMESTAMP: 2020-12-21T14:36:19+07:00

```
{
  "responseCode":2003000,
  "responseMessage":"Success",
  "virtualAccountData":{
    "partnerServiceId":" 088899",
    "customerNo":"12345678901234567890",
    "virtualAccountNo":" 08889912345678901234567890",
    "virtualAccountName":"Jokul Doe",
    "virtualAccountEmail":"jokul@email.com",
    "virtualAccountPhone":"6281828384858",
    "trxId":"abcdefgh1234",
    "totalAmount":{
      "value":"12345678.00",
      "currency":"IDR"
    },
    "billDetails":[
      {
        "billCode":"01",
        "billNo":"123456789012345678",
        "billName":"Bill A for Jan",
        "billShortName":"Bill A",
        "billDescription":{
          "english":"Maintenance",
          "indonesia":"Pemeliharaan"
        },
        "billSubCompany":"00001",
        "billAmount":{
          "value":"12345678.00",
          "currency":"IDR"
        },
        "additionalInfo":{
        }
      }
    ],
    "freeTexts":[
      {
        "english":"Free text",
        "indonesia":"Tulisan bebas"
      }
    ],
    "virtualAccountTrxType":"C",
    "feeAmount":{
      "value":"12345678.00",
      "currency":"IDR"
    },
    "expiredDate":"2020-12-31T23:59:59+07:00",
    "lastUpdateDate":"2020-12-31T23:59:59+07:00",
    "paymentDate":"2020-12-31T23:59:59+07:00",
  }
}
```

```
    "additionalInfo":{
      "deviceId":"12345679237",
      "channel":"mobilephone"
    }
  }
}
```



## h. Delete VA

### Informasi Umum

<b>Service Code</b>	31
<b>Name</b>	API Virtual Account – Delete VA
<b>Version</b>	1.0
<b>HTTP Method</b>	DELETE
<b>Path</b>	.../{version}/transfer-va/delete-va

### Request Body

<b>Parameter</b>	<b>Data Type</b>	<b>Mandatory</b>	<b>Length</b>	<b>Description</b>	<b>Example</b>
partnerServiceId	String	M	8	Derivative of X-PARTNER-ID, similar to company code, 8 digit left padding space.	“ 088899”
customerNo	String	M	20	Unique number (up to 20 digits).	“12345678901234567890”
virtualAccountNo	String	M	28	partnerServiceId (8 digit left padding space) + customerNo (up to 20 digits) or virtualAccountNo	“08889912345678901234567890”
trxId	String	O	64	Transaction ID in Partner system	abcdefgh1234

<b>Parameter</b>	<b>Data Type</b>	<b>Mandatory</b>	<b>Length</b>	<b>Description</b>	<b>Example</b>
additionalInfo	Object	O	N/A	Additional information for custom use that are not provided by SNAP	{ "deviceId": "12345679237", "channel": "mobilephone"; }

### Response Body

<b>Parameter</b>	<b>Data Type</b>	<b>Mandatory</b>	<b>Length</b>	<b>Description</b>	<b>Example</b>
responseCode	String	M	7	Response Code	2003100
responseMessage	String	M	150	Response Description	Success
virtualAccount Data	Object	M			
partnerServiceId	String	M	8	Derivative of X-PARTNER-ID, similar to company code, 8 digit left padding space.	“ 088899”
customerNo	String	M	20	Unique number (up to 20 digits).	“1234567890 1234567890”
virtualAccountNo	String	M	28	partnerServiceId (8 digit left padding space) + customerNo	“ 0888991234 5678901234 567890”

<b>Parameter</b>	<b>Data Type</b>	<b>Mandatory</b>	<b>Length</b>	<b>Description</b>	<b>Example</b>
				(up to 20 digits) or virtualAccountNo	
trxId	String	O	12	Transaction ID in Partner system	abcdefgh1234
additionalInfo	Object	O	N/A	Additional information for custom use that are not provided by SNAP	{"deviceId": "12345679237", "channel": "mobilephone"}

### Contoh Request

```
POST .../v1.0/transfer-va/delete-va HTTP/1.2
Content-type: application/json
Authorization: Bearer
gp9HjjEj813Y9JGoqwOeOPWbnt4CUpvIJbU1mMU4a11MNDZ7Sg5u9a"
Authorization-Customer: Bearer
fa8sjjEj813Y9JGoqwOeOPWbnt4CUpvIJbU1mMU4a11MNDZ7Sg5u9a"
X-TIMESTAMP: 2020-12-21T14:56:11+07:00
X-SIGNATURE:
85be817c55b2c135157c7e89f52499bf0c25ad6eebe04a986e8c86256
1b19a5
X-ORIGIN: www.hostname.com
X-PARTNER-ID: 82150823919040624621823174737537
X-EXTERNAL-ID: 41807553358950093184162180797837
X-IP-ADDRESS: 172.24.281.24
X-DEVICE-ID: 09864ADCASA
X-LATITUDE: -6.1617169
X-LONGITUDE: 106.6643946
CHANNEL-ID: 95221
```

```
{
  "partnerServiceId": " 088899",
  "customerNo": "12345678901234567890",
  "virtualAccountNo": " 08889912345678901234567890",
  "trxId": "abcdefgh1234",
  "additionalInfo": {
```

```
        "deviceId": "12345679237",
        "channel": "mobilephone"
    }
}
```

### Contoh Response

Content-type: application/json  
X-TIMESTAMP: 2020-12-21T14:36:19+07:00

```
{
  "responseCode": "2003100",
  "responseMessage": "Success",
  "virtualAccountData": {
    "partnerServiceId": " 088899",
    "customerNo": "12345678901234567890",
    "virtualAccountNo": " 08889912345678901234567890",
    "trxId": "abcdefgh1234",
    "additionalInfo": {
      "deviceId": "12345679237",
      "channel": "mobilephone"
    }
  }
}
```

### i. Inquiry Payment to VA from Intra Bank

#### Informasi Umum

<b>Service Code</b>	32
<b>Name</b>	API Virtual Account – Inquiry Payment to VA from Intra Bank
<b>Version</b>	1.0
<b>HTTP Method</b>	GET
<b>Path</b>	.../{version}/transfer-va/inquiry-intrabank

#### Request Body

<i>Parameter</i>	<i>Data Type</i>	<i>Mandatory</i>	<i>Length</i>	<i>Description</i>	<i>Example</i>
partnerServiceId	String	M	8	Derivative of X-PARTNER-ID , similar to company code, 8 digit left padding space.	“ 088899”
partnerReference No	String	O	128	Unique identifier for this Payment. Generated by Partner.	abcdef- 123456- abcdef
customerNo	String	M	20	Unique number (up to 20 digits).	1234567890 1234567890
virtualAccount No	String	M	28	partnerServiceId (8 digit left padding space) + customerNo	“ 0888991234 5678901234 567890”

<b>Parameter</b>	<b>Data Type</b>	<b>Mandatory</b>	<b>Length</b>	<b>Description</b>	<b>Example</b>
				(up to 20 digits)	
trxDateTime	<i>Date</i>	<i>O</i>	25	PJP internal system datetime with timezone, which follows the ISO-8601 standard	2020-10-20T17:56:57
channelCode	<i>Number</i>	<i>O</i>	4	Channel code based on ISO 18245	6011
language	<i>String</i>	<i>O</i>	2	Language code based on ISO 639-1	ID
amount	<i>Object</i>	<i>O</i>			
value	<i>String</i>	<i>M</i>	16,2	Nominal inputted by Customer with 2 decimal.	12345678.00
currency	<i>String</i>	<i>M</i>	3	Currency of amount based on ISO 4217.	IDR
sourceAccount No	<i>String</i>	<i>O</i>	32	Source account number	1234567890
sourceAccount Type	<i>String</i>	<i>O</i>	1	<b>D</b> = Current Account	S

<b>Parameter</b>	<b>Data Type</b>	<b>Mandatory</b>	<b>Length</b>	<b>Description</b>	<b>Example</b>
				<b>S</b> = Saving Account	
additionalInfo	Object	O	N/A	Additional information for custom use that are not provided by SNAP	{"deviceId": "12345679237", "channel": "mobilephone"}

### Response Body

<b>Parameter</b>	<b>Data Type</b>	<b>Mandatory</b>	<b>Length</b>	<b>Description</b>	<b>Example</b>
responseCode	String	M	7	Response Code	2003200
responseMessage	String	M	150	Response Description	Success
virtualAccount Data	Object	M			
inquiryStatus	String	O	2	Status of inquiry	00
inquiryReason	Object	O		Reason for Inquiry Status multi language	
english	String	O	64	Reason for Inquiry Status in English	Success
indonesia	String	O	64	Reason for Inquiry Status in Bahasa	Sukses
partnerServiceId	String	M	8	Derivative of X-PARTNER-ID ,	“ 088899”

<b>Parameter</b>	<b>Data Type</b>	<b>Mandatory</b>	<b>Length</b>	<b>Description</b>	<b>Example</b>
				similar to company code, 8 digit left padding space.	
partnerReference No	String	O	128	Unique identifier for this Payment. Generated by Partner.	abcdef-123456-abcdef
customerNo	String	M	20	Unique number (up to 20 digits).	1234567890 1234567890
virtualAccount No	String	M	28	partnerServiceId (8 digit left padding space) + customerNo (up to 20 digits)	“08889912345678901234567890”
virtualAccount Name	String	O	255	Customer name	Jokul Doe
virtualAccount Email	String	O	255	Customer email	john@email.com
virtualAccount Phone	String	O	30	Customer’s phone number Format: 62xxxxxxxxxxxxxx	6281828384858
sourceAccount No	String	O	32	Source account number	1234567890
sourceAccount Type	String	O	1	<b>D</b> = Current Account	S



<b>Parameter</b>	<b>Data Type</b>	<b>Mandatory</b>	<b>Length</b>	<b>Description</b>	<b>Example</b>
				<b>S</b> = Saving Account	
inquiryRequestId	String	O	128	Inquiry identifier for Inquiry. Generated by PJP.	abcdef-123456-abcdef
totalAmount	Object	O			
value	String	M	16,2	Total Amount with 2 decimal.	12345678.00
currency	String	M	3	Currency of amount based on ISO 4217.	IDR
billDetails	Array of Objects	O		Array with maximum 24 Objects	
billCode	String	O	2	Bill code for Customer choose	01
billNo	String	O	18	Bill number from Partner	1234567890 12345678
billName	String	O	20	Bill Name	Bill A for Jan
billShortName	String	O	10	Bill Name to shown to	Bill A
billDescription	Object	O		Bill Description	
english	String	O	18	Bill Description in English	Maintenance
indonesia	String	O	18	Bill Description in Bahasa	Pemeliharaan

<b>Parameter</b>	<b>Data Type</b>	<b>Mandatory</b>	<b>Length</b>	<b>Description</b>	<b>Example</b>
billSubCompany	String	O	5	Partner's product code	00001
billAmount	Object	O			
value	String	M	16,2	Billing Amount with 2 decimal digits	12345678.00
currency	String	M	3	Currency (ISO 4217)	IDR
billAmountLabel	String	O	25	Label for billAmount	Total Tagihan
billAmountValue	Object	O	25	Value that will be shown for billAmount	Rp. 50.000,-
additionalInfo	Object	O	N/A	Additional Information for custom use for each bill	
freeTexts	Array of Objects	O		Array with maximum 25 Objects	
english	String	O	32	Will be shown in Channel	Free text
indonesia	String	O	32	Will be shown in Channel	Tulisan bebas
virtualAccount TrxType	String	O	1	Type of Virtual Account <b>C</b> = Closed Payment <b>O</b> = Open Payment <b>I</b> = Partial	C

<b>Parameter</b>	<b>Data Type</b>	<b>Mandatory</b>	<b>Length</b>	<b>Description</b>	<b>Example</b>
				<b>M</b> = Minimum - only can be paid once with minimum amount <b>L</b> = Maximum <b>N</b> = Open Minimum - can be paid multiple with minimum amount <b>X</b> = Open Maximum - can be paid multiple with cumulative maximum amount) <b>V</b> = Bill Variable <b>W</b> = Multi Bill Variable	
feeAmount	Object	O			
value	String	M	16,2	Nominal inputted by Customer with 2 decimal.	12345678.00
currency	String	M	3	Currency (ISO 4217)	IDR
productName	String	O	30	Product Category	Pendidikan
additionalInfo	Object	O	N/A	Additional information for custom use that are not provided by SNAP	{ "deviceId": "12345679237", "channel": "mobilephone"}

### Contoh Request

POST .../v1.0/transfer-va/inquiry-intrabank HTTP/1.2

```
Content-type: application/json
Authorization: Bearer
gp9HjjEj813Y9JGoqwOeOPWbnt4CUpvIJbU1mMU4a11MNDZ7Sg5u9a"
Authorization-Customer: Bearer
fa8sjjEj813Y9JGoqwOeOPWbnt4CUpvIJbU1mMU4a11MNDZ7Sg5u9a"
X-TIMESTAMP: 2020-12-21T14:56:11+07:00
X-SIGNATURE:
85be817c55b2c135157c7e89f52499bf0c25ad6eebe04a986e8c86256
1b19a5
X-ORIGIN: www.hostname.com
X-PARTNER-ID: 82150823919040624621823174737537
X-EXTERNAL-ID: 41807553358950093184162180797837
X-IP-ADDRESS: 172.24.281.24
X-DEVICE-ID: 09864ADCASA
X-LATITUDE: -6.1617169
X-LONGITUDE: 106.6643946
CHANNEL-ID: 95221
```

```
{
  "partnerServiceId": " 088899",
  "partnerReferenceNo": "abcdef-123456-abcdef",
  "customerNo": "12345678901234567890",
  "virtualAccountNo": " 08889912345678901234567890",
  "trxDateTime": "2020-10-20T17:56:57",
  "channelCode": "6011",
  "language": "ID",
  "amount": {
    "value": "12345678.00",
    "currency": "IDR"
  },
  "sourceAccountNo": "1234567890",
  "sourceAccountType": "S",
  "additionalInfo": {
    "deviceId": "12345679237",
    "channel": "mobilephone"
  }
}
```

### Contoh Response

```
Content-type: application/json
X-TIMESTAMP: 2020-12-21T14:36:19+07:00
```

```
{
  "responseCode": "2003200",
  "responseMessage": "Success",
  "virtualAccountData": {
    "inquiryStatus": "00",
    "inquiryReason": {
      "english": "Success",

```

```

    "indonesia": "Sukses"
  },
  "partnerServiceId": " 088899",
  "partnerReferenceNo": "abcdef-123456-abcdef",
  "customerNo": "12345678901234567890",
  "virtualAccountNo": " 08889912345678901234567890",
  "virtualAccountName": "Jokul Doe",
  "virtualAccountEmail": "john@email.com",
  "virtualAccountPhone": "6281828384858",
  "sourceAccountNo": "1234567890",
  "sourceAccountType": "S",
  "inquiryRequestId": "abcdef-123456-abcdef",
  "totalAmount": {
    "value": "12345678.00",
    "currency": "IDR"
  },
  "billDetails": [
    {
      "billCode": "01",
      "billNo": "123456789012345678",
      "billName": "Bill A for Jan",
      "billShortName": "Bill A",
      "billDescription": {
        "english": "Maintenance",
        "indonesia": "Pemeliharaan"
      },
      "billSubCompany": "00001",
      "billAmount": {
        "value": "12345678.00",
        "currency": "IDR"
      },
      "billAmountLabel": "Total Tagihan",
      "billAmountValue": "Rp. 50.000,-",
      "additionalInfo": {
      }
    }
  ],
  "freeTexts": [
    {
      "english": "Free text",
      "indonesia": "Tulisan bebas"
    }
  ],
  "virtualAccountTrxType": "C",
  "feeAmount": {
    "value": "12345678.00",
    "currency": "IDR"
  },
  "productName": "Pendidikan",
  "additionalInfo": {

```

```
        "deviceId": "12345679237",  
        "channel": "mobilephone"  
    }  
}
```

## j. Payment to VA from Intra Bank

### Informasi Umum

<b>Service Code</b>	33
<b>Name</b>	API Virtual Account – Payment to VA from Intra Bank
<b>Version</b>	1.0
<b>HTTP Method</b>	POST
<b>Path</b>	.../{version}/transfer-va/payment-intrabank

### Request Body

<i>Parameter</i>	<i>Data Type</i>	<i>Mandatory</i>	<i>Length</i>	<i>Description</i>	<i>Example</i>
partnerServiceId	String	M	8	Derivative of X-PARTNER-ID , similar to company code, 8 digit left padding space.	“ 088899”
customerNo	String	M	20	Unique number (up to 20 digits).	“12345678901234567890”
referenceNo	String	O	15	Trancation Identifier on Service Provider System	123456789012345
virtualAccountNo	String	M	28	partnerServiceId (8 digit left padding space) + customerNo (up to 20 digits). partnerServiceId + customerNo or	“08889912345678901234567890”

<b>Parameter</b>	<b>Data Type</b>	<b>Mandatory</b>	<b>Length</b>	<b>Description</b>	<b>Example</b>
				virtualAccount No	
virtualAccount Name	<i>String</i>	<i>O</i>	255	Customer name	Jokul Doe
virtualAccount Email	<i>String</i>	<i>O</i>	255	Customer email	jokul@email.com
virtualAccount Phone	<i>String</i>	<i>O</i>	30	Customer's phone number Format: 62xxxxxxxxxxx xxx	6281828384 858
sourceAccount No	<i>String</i>	<i>O</i>	32	Source account number	1234567890
sourceAccount Type	<i>String</i>	<i>O</i>	1	<b>D</b> = Current Account <b>S</b> = Saving Account	S
inquiryRequestId	<i>String</i>	<i>O</i>	128	From Inquiry Request	abcdef-123456-abcdef
partnerReference No	<i>String</i>	<i>M</i>	128	From Payment Request.	abcdef-123456-abcdef
paidAmount	<i>Object</i>	<i>M</i>			
value	<i>String</i>	<i>M</i>	16,2	Paid Amount with 2 decimal.	12345678.00
currency	<i>String</i>	<i>M</i>	3	Currency. (ISO 4217)	IDR



<b>Parameter</b>	<b>Data Type</b>	<b>Mandatory</b>	<b>Length</b>	<b>Description</b>	<b>Example</b>
cumulativePaymentAmount	<i>Object</i>	O			
value	<i>String</i>	M	16,2	Cumulative Amount from virtualAccount No paid multiple times.	12345678.00
currency	<i>String</i>	M	3	Currency (ISO 4217)	IDR
paidBills	<i>String</i>	O	6	Hexadecimal format of binary of flag of paid bills.  If there are 24 bills, and paid bills number 1, 4, 6, and 8, will be written in binary 10010101000 00000000000 00 and converted to Hexa.	95000
totalAmount	<i>Object</i>	O			
value	<i>String</i>	M	16,2	Total amount from Inquiry	12345678.00

<b>Parameter</b>	<b>Data Type</b>	<b>Mandatory</b>	<b>Length</b>	<b>Description</b>	<b>Example</b>
				with 2 decimal.	
currency	String	M	3	Currency (ISO 4217)	IDR
trxDateTime	Date	O	25	PJP internal system datetime with timezone, which follows the ISO-8601 standard	2020-10-20T17:56:57
journalNum	String	O	6	Sequence journal number in PJP Core System	123456
paymentType	String	O	1	Type of payment <b>1</b> = Cash <b>2</b> = Transfer	1
flagAdvise	String	O	1	Flag to indicate is this a retry notification <b>Y</b> = Retry notification <b>N</b> = New notification	Y

<b>Parameter</b>	<b>Data Type</b>	<b>Mandatory</b>	<b>Length</b>	<b>Description</b>	<b>Example</b>
paymentStatus	String	O	20	Status of payment request	In Progress
billDetails	Array of Objects	O		Array with maximum 24 Objects	
billCode	String	O	2	From Inquiry Response	01
billNo	String	O	18	From Inquiry Response	1234567890 12345678
billName	String	O	20	From Inquiry Response	Bill A for Jan
billShortName	String	O	10	From Inquiry Response	Bill A
billDescription	Object	O		From Inquiry Response	
english	String	O	18	From Inquiry Response	Maintenance
indonesia	String	O	18	From Inquiry Response	Pemeliharaan
billSubCompany	String	O	5	From Inquiry Response	00001
billAmount	Object	O			
value	String	M	16,2	From Inquiry Response.	12345678.00
currency	String	M	3	From Inquiry Response.	IDR
additionalInfo	Object	O	N/A	From Inquiry Response	

<b>Parameter</b>	<b>Data Type</b>	<b>Mandatory</b>	<b>Length</b>	<b>Description</b>	<b>Example</b>
billReferenceNo	Number	O	15	Bill auth code generated by PJP	1234567890 12345
freeTexts	Array of Objects	O		Array with maximum 25 Objects	
english	String	O	32	Will be shown in Channel	Free text
indonesia	String	O	32	Will be shown in Channel	Tulisan bebas
feeAmount	Object	O			
value	String	M	16,2	Nominal inputted by Customer with 2 decimal	12345678.00
currency	String	M	3	Currency (ISO 4217)	IDR
additionalInfo	Object	O	N/A	Additional information for custom use that are not provided by SNAP	{"deviceId": "12345679237", "channel": "mobilephone"}

### Response Body

<b>Parameter</b>	<b>Data Type</b>	<b>Mandatory</b>	<b>Length</b>	<b>Description</b>	<b>Example</b>
responseCode	String	M	7	Response Code	2003300
responseMessage	String	M	150	Response Description	Success

<b>Parameter</b>	<b>Data Type</b>	<b>Mandatory</b>	<b>Length</b>	<b>Description</b>	<b>Example</b>
virtualAccount Data	<i>Object</i>	<i>M</i>			
paymentFlagReason	<i>Object</i>	<i>O</i>		Reason for Payment Status multi language	
english	<i>String</i>	<i>O</i>	200	Reason for Payment in English	Success
indonesia	<i>String</i>	<i>O</i>	200	Reason for Payment in Bahasa	Sukses
partnerServiceId	<i>String</i>	<i>M</i>	8	Derivative of X-PARTNER-ID , similar to company code, 8 digit left padding space.	“ 088899”
customerNo	<i>String</i>	<i>M</i>	20	Unique number (up to 20 digits).	1234567890 1234567890
virtualAccount No	<i>String</i>	<i>M</i>	28	partnerServiceId (8 digit left padding space) + customerNo (up to 20 digits)	“ 0888991234 5678901234 567890”

<b>Parameter</b>	<b>Data Type</b>	<b>Mandatory</b>	<b>Length</b>	<b>Description</b>	<b>Example</b>
virtualAccount Name	String	M	255	Customer name	Jokul Doe
virtualAccount Email	String	O	255	Customer email	jokul@email.com
virtualAccount Phone	String	O	30	Customer's phone number Format: 62xxxxxxxxxx xxxx	6281828384 858
sourceAccount No	String	O	32	Source account number	1234567890
sourceAccount Type	String	O	1	<b>D</b> = Current Account <b>S</b> = Saving Account	S
inquiryRequestId	String	O	128	From Payment Request	abcdef-123456-abcdef
paymentRequestId	String	O	128	Unique Identifier for Payment. Generated by PJP and has the value with generated paymentReq	abcdef-123456-abcdef

<b>Parameter</b>	<b>Data Type</b>	<b>Mandatory</b>	<b>Length</b>	<b>Description</b>	<b>Example</b>
				uestId to Partner Bill.	
partnerReferenceNo	String	M	128	From Payment Request.	abcdef-123456-abcdef
referenceNo	String	O	128	Generated by PJP.	abcdef-123456-abcdef
paidAmount	Object	O			
value	String	M	16,2	From Payment Request.	12345678.00
currency	String	M	3	From Payment Request.	IDR
paidBills	String	O	6	From Payment Request	95000
totalAmount	Object	O			
value	String	M	16,2	From Payment Request.	12345678.00
currency	String	M	3	From Payment Request.	IDR
trxDateTime	Date	O	25	From Payment Request	2020-10-20T17:56:57

<b>Parameter</b>	<b>Data Type</b>	<b>Mandatory</b>	<b>Length</b>	<b>Description</b>	<b>Example</b>
referenceNo	String	O	15	From Payment Request	1234567890 12345
journalNum	String	O	6	Sequence journal number in PJP Core System	123456
paymentType	String	O	1	From Payment Request  <b>1</b> = Cash <b>2</b> = Transfer	1
flagAdvise	String	O	1	From Payment Request  <b>Y</b> = Retry notification <b>N</b> = New notification	Y
billDetails	Array of Objects	O		Array with maximum 24 Objects	
billCode	String	O	2	From Inquiry Response	01
billNo	String	O	18	From Inquiry Response	1234567890 12345678



<b>Parameter</b>	<b>Data Type</b>	<b>Mandatory</b>	<b>Length</b>	<b>Description</b>	<b>Example</b>
billName	String	O	20	From Inquiry Response	Bill A for Jan
billShortName	String	O	10	From Inquiry Response	Bill A
billDescription	Object	O		From Inquiry Response	
english	String	O	18	From Inquiry Response	Maintenance
indonesia	String	O	18	From Inquiry Response	Pemeliharaan
billSubCompany	String	O	5	From Inquiry Response	00001
billAmount	Object	O			
value	String	M	16,2	From Inquiry Response.	12345678.00
currency	String	M	3	Currency (ISO 4217)	IDR
additionalInfo	Object	O		From Inquiry Response	
status	String	O	2	Payment status for specific Bill	00
reason	String	O	2	Reason for Payment Status for specific Bill multi language	
indonesia	String	O	64	Reason for Payment	Success

<b>Parameter</b>	<b>Data Type</b>	<b>Mandatory</b>	<b>Length</b>	<b>Description</b>	<b>Example</b>
				Status for specific Bill in English	
english	String	O	64	Reason for Payment Status for specific Bill in Bahasa	Sukses
freeTexts	Array of Objects	O		Array with maximum 25 Objects	
english	String	O	32	Will be shown in Channel	Free text
indonesia	String	O	32	Will be shown in Channel	Tulisan bebas
feeAmount	Object	O			
value	String	M	16,2	Nominal inputted by Customer with 2 decimal.	12345678.00
currency	String	M	3	Currency (ISO 4217)	IDR
productName	String	O	30	Product Category	Pendidikan
additionalInfo	Object	O	N/A	Additional information for custom use that are	{"deviceId": "12345679237", "channel": "mobilephone"}

<b>Parameter</b>	<b>Data Type</b>	<b>Mandatory</b>	<b>Length</b>	<b>Description</b>	<b>Example</b>
				not provided by SNAP	

### Contoh Request

```
POST .../v1.0/transfer-va/payment-intrabank HTTP/1.2
Content-type: application/json
Authorization: Bearer
gp9HjjEj813Y9JGoqwOeOPWbnt4CUpvIJbU1mMU4a11MNDZ7Sg5u9a"
Authorization-Customer: Bearer
fa8sjjEj813Y9JGoqwOeOPWbnt4CUpvIJbU1mMU4a11MNDZ7Sg5u9a"
X-TIMESTAMP: 2020-12-21T14:56:11+07:00
X-SIGNATURE:
85be817c55b2c135157c7e89f52499bf0c25ad6eebe04a986e8c86256
1b19a5
X-ORIGIN: www.hostname.com
X-PARTNER-ID: 82150823919040624621823174737537
X-EXTERNAL-ID: 41807553358950093184162180797837
X-IP-ADDRESS: 172.24.281.24
X-DEVICE-ID: 09864ADCASA
X-LATITUDE: -6.1617169
X-LONGITUDE: 106.6643946
CHANNEL-ID: 95221
```

```
{
  "partnerServiceId": " 088899",
  "customerNo": 12345678901234567890,
  "referenceNo": 123456789012345,
  "virtualAccountNo": " 08889912345678901234567890",
  "virtualAccountName": "Jokul Doe",
  "virtualAccountEmail": "jokul@email.com",
  "virtualAccountPhone": "6281828384858",
  "sourceAccountNo": "1234567890",
  "sourceAccountType": "S",
  "inquiryRequestId": "abcdef-123456-abcdef",
  "partnerReferenceNo": "abcdef-123456-abcdef",
  "paidAmount": {
    "value": "12345678.00",
    "currency": "IDR"
  },
  "cumulativePaymentAmount": {
    "value": "12345678.00",
    "currency": "IDR"
  },
  "paidBills": "950000",
  "totalAmount": {
    "value": "12345678.00",
```

```

    "currency": "IDR"
  },
  "trxDateTime": "2020-10-20T17:56:57",
  "journalNum": "123456",
  "paymentType": 1,
  "flagAdvise": "Y",
  "paymentStatus": "In Progress",
  "billDetails": [
    {
      "billCode": "01",
      "billNo": "123456789012345678",
      "billName": "Bill A for Jan",
      "billShortName": "Bill A",
      "billDescription": {
        "english": "Maintenance",
        "indonesia": "Pemeliharaan"
      },
      "billSubCompany": "00001",
      "billAmount": {
        "value": "12345678.00",
        "currency": "IDR"
      },
      "additionalInfo": {
      },
      "billReferenceNo": "123456789012345"
    }
  ],
  "freeTexts": [
    {
      "english": "Free text",
      "indonesia": "Tulisan bebas"
    }
  ],
  "feeAmount": {
    "value": "12345678.00",
    "currency": "IDR"
  },
  "additionalInfo": {
  }
}

```

### Contoh Response

```

Content-type: application/json
X-TIMESTAMP: 2020-12-21T14:36:19+07:00

```

```

{
  "responseCode": "2003300",
  "responseMessage": "Success",

```

```

"virtualAccountData":{
  "paymentFlagReason":{
    "english":"Success",
    "indonesia":"Sukses"
  },
  "partnerServiceId":" 088899",
  "customerNo":"12345678901234567890",
  "virtualAccountNo":" 08889912345678901234567890",
  "virtualAccountName":"Jokul Doe",
  "virtualAccountEmail":"jokul@email.com",
  "virtualAccountPhone":"6281828384858",
  "sourceAccountNo":"1234567890",
  "sourceAccountType":"S",
  "inquiryRequestId":"abcdef-123456-abcdef",
  "paymentRequestId":"abcdef-123456-abcdef",
  "partnerReferenceNo":"abcdef-123456-abcdef",
  "referenceNo":"abcdef-123456-abcdef",
  "paidAmount":{
    "value":"12345678.00",
    "currency":"IDR"
  },
  "paidBills":"95000",
  "totalAmount":{
    "value":"12345678.00",
    "currency":"IDR"
  },
  "trxDateTime":"2020-10-20T17:56:57",
  "referenceNo":"123456789012345",
  "journalNum":"123456",
  "paymentType":1,
  "flagAdvise":"Y",
  "billDetails":[
    {
      "billCode":"01",
      "billNo":"123456789012345678",
      "billName":"Bill A for Jan",
      "billShortName":"Bill A",
      "billDescription":{
        "english":"Maintenance",
        "indonesia":"Pemeliharaan"
      },
      "billSubCompany":"00001",
      "billAmount":{
        "value":"12345678.00",
        "currency":"IDR"
      },
      "additionalInfo":{
      },
      "status":"00",
      "reason":{

```

```
        "english": "Success",
        "indonesia": "Sukses"
    }
}
],
"freeTexts": [
    {
        "english": "Free text",
        "indonesia": "Tulisan bebas"
    }
],
"feeAmount": {
    "value": "12345678.00",
    "currency": "IDR"
},
"productName": "Pendidikan"
},
"additionalInfo": {
}
}
```

## k. Notification for Payment to VA from Intra Bank

### Informasi Umum

<b>Service Code</b>	34
<b>Name</b>	API Virtual Account – Notification for Payment to VA from Intra Bank
<b>Version</b>	1.0
<b>HTTP Method</b>	POST
<b>Path</b>	.../{version}/transfer-va/notify-payment-intrabank

### Request Body

<i>Parameter</i>	<i>Data Type</i>	<i>Mandatory</i>	<i>Length</i>	<i>Description</i>	<i>Example</i>
partnerServiceId	String	M	8	Derivative of X-PARTNER-ID , similar to company code, 8 digit left padding space.	“ 088899”
customerNo	String	M	20	Unique number (up to 20 digits).	“12345678901234567890”
virtualAccountNo	String	M	28	partnerServiceId (8 digit left padding space) + customerNo (up to 20 digits) or virtualAccountNo	“088899123456789012345678900”
inquiryRequestId	String	O	128	From Inquiry Request	abcdef-123456-abcdef

<b>Parameter</b>	<b>Data Type</b>	<b>Mandatory</b>	<b>Length</b>	<b>Description</b>	<b>Example</b>
paymentRequestId	<i>String</i>	O	128	Unique identifier generated by PJP. If Payment comes from the Inquiry process, this value must be the same with inquiryRequestId.	abcdef-123456-abcdef
partnerReferenceNo	<i>String</i>	O	128	Unique identifier for this Payment. Generated by Partner.	abcdef-123456-abcdef
trxDateTime	<i>Date</i>	O	25	PJP internal system datetime with timezone, which follows the ISO-8601 standard	2020-12-21T14:56:11+07:00
paymentStatus	<i>String</i>	O	20	Status of payment request	Success
paymentFlagReason	<i>Object</i>	O		Reason for Payment	



<b>Parameter</b>	<b>Data Type</b>	<b>Mandatory</b>	<b>Length</b>	<b>Description</b>	<b>Example</b>
				Status multi language	
english	String	O	200	Reason for Payment Status in English	Success
indonesia	String	O	200	Reason for inquiryStatus in Bahasa	Sukses
additionalInfo	Object	O	N/A	Additional information for custom use that are not provided by SNAP	

### Response Body

<b>Parameter</b>	<b>Data Type</b>	<b>Mandatory</b>	<b>Length</b>	<b>Description</b>	<b>Example</b>
responseCode	String	M	7	Response Code	2003400
responseMessage	String	M	150	Response Description	Success
virtualAccount Data	Object	O			
paymentFlagReason	Object	O		Reason for Payment Status multi language	

<b>Parameter</b>	<b>Data Type</b>	<b>Mandatory</b>	<b>Length</b>	<b>Description</b>	<b>Example</b>
english	String	O	200	Reason for Payment Status in English	Success
indonesia	String	O	200	Reason for inquiryStatus in Bahasa	Sukses
partnerServiceId	String	M	8	Derivative of X-PARTNER-ID , similar to company code, 8 digit left padding space.	“ 088899”
customerNo	String	M	20	Unique number (up to 20 digits).	“12345678901234567890”
virtualAccountNo	String	M	28	partnerServiceId (8 digit left padding space) + customerNo (up to 20 digits) or virtualAccountNo	“088899123456789012345678900”

<b>Parameter</b>	<b>Data Type</b>	<b>Mandatory</b>	<b>Length</b>	<b>Description</b>	<b>Example</b>
inquiryRequestId	<i>String</i>	O	128	From Inquiry Request	abcdef-123456-abcdef
paymentRequestId	<i>String</i>	O	128	Unique identifier generated by PJP. If Payment comes from the Inquiry process, this value must be the same with inquiryRequestId.	abcdef-123456-abcdef
partnerReference No	<i>String</i>	O	128	Unique identifier for this Payment. Generated by Partner.	abcdef-123456-abcdef
trxDateTime	<i>Date</i>	O	25	PJP internal system datetime with timezone, which follows the	2020-12-21T14:56:11+07:00

<b>Parameter</b>	<b>Data Type</b>	<b>Mandatory</b>	<b>Length</b>	<b>Description</b>	<b>Example</b>
				ISO-8601 standard	
paymentStatus	String	O	20	Status of payment request	In Progress
additionalInfo	Object	O	N/A	Additional information for custom use that are not provided by SNAP	

### Contoh Request

```

POST .../v1.0/transfer-va/notify-payment-intrabank HTTP/1.2
Content-type: application/json
Authorization: Bearer
gp9HjjEj813Y9JGoqwOeOPWbnt4CUpvIJbU1mMU4a11MNDZ7Sg5u9a"
Authorization-Customer: Bearer
fa8sjjEj813Y9JGoqwOeOPWbnt4CUpvIJbU1mMU4a11MNDZ7Sg5u9a"
X-TIMESTAMP: 2020-12-21T14:56:11+07:00
X-SIGNATURE:
85be817c55b2c135157c7e89f52499bf0c25ad6eebe04a986e8c86256
1b19a5
X-ORIGIN: www.hostname.com
X-PARTNER-ID: 82150823919040624621823174737537
X-EXTERNAL-ID: 41807553358950093184162180797837
X-IP-ADDRESS: 172.24.281.24
X-DEVICE-ID: 09864ADCASA
X-LATITUDE: -6.1617169
X-LONGITUDE: 106.6643946
CHANNEL-ID: 95221
{
  "partnerServiceId": " 088899",
  "customerNo": 12345678901234567890,
  "virtualAccountNo": " 08889912345678901234567890",
  "inquiryRequestId": "abcdef-123456-abcdef",
  "paymentRequestId": "abcdef-123456-abcdef",
  "partnerReferenceNo": "abcdef-123456-abcdef",
  "trxDateTime": "2020-12-21T14:56:11+07:00",

```

```

    "paymentStatus":"Success",
    "paymentFlagReason":{
      "english":"Success",
      "indonesia":"Sukses"
    },
    "additionalInfo":{
  }
}

```

### Contoh Response

```

Content-type: application/json
X-TIMESTAMP: 2020-12-21T14:36:19+07:00
X-SIGNATURE:
85be8171923ac135157c7e89f52499bf0c25ad6eebe04a986e8c86256
1b19a5

```

```

{
  "responseCode":2003400,
  "responseMessage":"Success",
  "virtualAccountData":{
    "paymentFlagReason":{
      "english":"Success",
      "indonesia":"Sukses"
    },
    "partnerServiceId":" 088899",
    "customerNo":12345678901234567890,
    "virtualAccountNo":" 08889912345678901234567890",
    "inquiryRequestId":"abcdef-123456-abcdef",
    "paymentRequestId":"abcdef-123456-abcdef",
    "partnerReferenceNo":"abcdef-123456-abcdef",
    "trxDateTime":"2020-12-21T14:56:11+07:00",
    "paymentStatus":"In Progress",
    "additionalInfo":{
  }
}
}

```

## 1. Get Report

### Informasi Umum

<b>Service Code</b>	35
<b>Name</b>	API Virtual Account – Get Report
<b>Version</b>	1.0
<b>HTTP Method</b>	GET
<b>Path</b>	.../{version}/transfer-va/report

### Request Body

<i>Parameter</i>	<i>Data Type</i>	<i>Mandatory</i>	<i>Length</i>	<i>Description</i>	<i>Example</i>
partnerService Id	<i>String</i>	<i>M</i>	8	From Payment Request.  Derivative of X-PARTNER-ID , similar to company code, 8 digit left padding space.	“ 088899”
startDate	<i>String</i>	<i>O</i>	10	Start Date for Report yyyy-MM-dd  ISO-8601	2020-12-31
startTime	<i>String</i>	<i>O</i>	14	Start Time for Report. HH:mm If used, must send startDate If startDate exists without startTime, default	14:56:11+07:00

<b>Parameter</b>	<b>Data Type</b>	<b>Mandatory</b>	<b>Length</b>	<b>Description</b>	<b>Example</b>
				startTime = 00:00  ISO-8601	
endDate	String	O	10	End Date for Report yyyy-MM-dd If used, must send startDate  ISO-8601	2021-12-31
endTime	String	O	14	End Time for Report. HH:mm If used, must send endDate. If endDate exists without endTime, default endTime = 23:59  ISO-8601	14:56:11+07:00
additionalInfo	Object	O	N/A	From Inquiry Response	

## Response Body

<b>Parameter</b>	<b>Data Type</b>	<b>Mandatory</b>	<b>Length</b>	<b>Description</b>	<b>Example</b>
responseCode	String	M	7	Response Code	2003500
responseMessage	String	M	150	Response Description	Success
virtualAccount Data	Array of Objects	M			
paymentFlagReason	Object	O		Reason for Payment Status multi language	
english	String	O	200	Reason for Payment Status in English	Success
indonesia	String	O	200	Reason for inquiryStatus in Bahasa	Sukses
partnerServiceId	String	M	8	Derivative of X-PARTNER-ID , similar to company code, 8 digit left padding space	“ 088899”
customerNo	String	M	20	Unique number (up to 20 digits)	“12345678901234567890”



<b>Parameter</b>	<b>Data Type</b>	<b>Mandatory</b>	<b>Length</b>	<b>Description</b>	<b>Example</b>
virtualAccount No	String	M	28	partnerServiceId (8 digit left padding space) + customerNo (up to 20 digits) or virtualAccountNo	“08889912345678901234567890”
virtualAccount Name	String	M	255	Customer name	Jokul Doe
virtualAccount Email	String	O	255	Customer email	jokul@email.com
virtualAccount Phone	String	O	30	Customer's phone number Format: 62xxxxxxxxxxxx	6281828384858
sourceAccount No	String	O	32	Source account number	1234567890
sourceAccount Type	String	O	1	<b>D</b> = Current Account <b>S</b> = Saving Account	S
trxId	String	O	64	From Payment Request	abcdefgh1234

<b>Parameter</b>	<b>Data Type</b>	<b>Mandatory</b>	<b>Length</b>	<b>Description</b>	<b>Example</b>
inquiryRequestId	String	O	128	From Payment Request	abcdef-123456-abcdef
paymentRequestId	String	O	128	From Payment Request	abcdef-123456-abcdef
paidAmount	Object	O			
value	String	M	16,2	From Payment Request.	12345678.00
currency	String	M	3	Currency (ISO 4217)	IDR
paidBills	String	O	6	Hexadecimal format of binary of flag of paid bills.  If there are 24 bills, and paid bills number 1, 4, 6, and 8, will be written in binary 1001010100 0000000000 0000 and	95000

<b>Parameter</b>	<b>Data Type</b>	<b>Mandatory</b>	<b>Length</b>	<b>Description</b>	<b>Example</b>
				converted to Hexa.	
totalAmount	Object	O			
value	String	M	16,2	From Payment Request.	12345678.00
currency	String	M	3	Currency (ISO 4217)	IDR
trxDateTime	String	O	25	From Payment Request	20201231T235959Z
referenceNo	String	O	15	From Payment Request	123456789012345
journalNum	String	O	6	Sequence journal number in PJP Core System	123456
paymentType	String	O	1	From Payment Request <b>1</b> = Cash <b>2</b> = Transfer	1
flagAdvise	String	O	1	From Payment Request	Y

<b>Parameter</b>	<b>Data Type</b>	<b>Mandatory</b>	<b>Length</b>	<b>Description</b>	<b>Example</b>
				<b>Y</b> = Retry notification <b>N</b> = New notification	
billDetails	Array of Objects	O		Array with maximum 24 Objects	
billCode	String	O	2	From Inquiry Response	01
billNo	String	O	18	From Inquiry Response	1234567890 12345678
billName	String	O	20	From Inquiry Response	Bill A for Jan
billShortName	String	O	10	From Inquiry Response	Bill A
billDescription	Object	O		From Inquiry Response	
english	String	O	18	From Inquiry Response	Maintenance
indonesia	String	O	18	From Inquiry Response	Pemeliharaan

<b>Parameter</b>	<b>Data Type</b>	<b>Mandatory</b>	<b>Length</b>	<b>Description</b>	<b>Example</b>
billSubCompany	String	O	5	From Inquiry Response	00001
billAmount	Object	O			
value	String	M	16,2	From Inquiry Response.	12345678.00
currency	String	M	3	Currency (ISO 4217)	IDR
additionalInfo	Object	O		From Inquiry Response	
status	String	O	2	Payment status for specific Bill	00
reason	String	O	2	Reason for Payment Status for specific Bill multi language	
english	String	O	64	Reason for Payment Status for specific Bill in English	Success
indonesia	String	O	64	Reason for Payment Status for	Sukses

<b>Parameter</b>	<b>Data Type</b>	<b>Mandatory</b>	<b>Length</b>	<b>Description</b>	<b>Example</b>
				specific Bill in Bahasa	
freeTexts	Array of Objects	O		From Inquiry Response. Array with maximum 25 Objects	
english	String	O	32	From Inquiry Response	Free text
indonesia	String	O	32	From Inquiry Response	Tulisan bebas
additionalInfo	Object	O	N/A	From Inquiry Response	

### Contoh Request

```

POST .../v1.0/transfer-va/report HTTP/1.2
Content-type: application/json
Authorization: Bearer
gp9HjjEj813Y9JGoqwOeOPWbnt4CUpvIJbU1mMU4a11MNDZ7Sg5u9a"
Authorization-Customer: Bearer
fa8sjjEj813Y9JGoqwOeOPWbnt4CUpvIJbU1mMU4a11MNDZ7Sg5u9a"
X-TIMESTAMP: 2020-12-21T14:56:11+07:00
X-SIGNATURE:
85be817c55b2c135157c7e89f52499bf0c25ad6eeeb04a986e8c86256
1b19a5
X-ORIGIN: www.hostname.com
X-PARTNER-ID: 82150823919040624621823174737537
X-EXTERNAL-ID: 41807553358950093184162180797837
X-IP-ADDRESS: 172.24.281.24
X-DEVICE-ID: 09864ADCASA
X-LATITUDE: -6.1617169

```

X-LONGITUDE: 106.6643946  
CHANNEL-ID: 95221

```
{
  "partnerServiceId": " 088899",
  "startDate": "2020-12-31",
  "startTime": "14:56:11+07:00",
  "endDate": "2021-12-31",
  "endTime": "14:56:11+07:00",
  "additionalInfo": {
  }
}
```

### Contoh Response

Content-type: application/json  
X-TIMESTAMP: 2020-12-21T14:36:19+07:00  
X-SIGNATURE:  
85be8171923ac135157c7e89f52499bf0c25ad6eebe04a986e8c86256  
1b19a5

```
{
  "responseCode": 2003500,
  "responseMessage": "Success",
  "virtualAccountData": [
    {
      "paymentFlagReason": {
        "english": "Success",
        "indonesia": "Sukses"
      },
      "partnerServiceId": " 088899",
      "customerNo": "12345678901234567890",
      "virtualAccountNo": " 08889912345678901234567890",
      "virtualAccountName": "Jokul Doe",
      "virtualAccountEmail": "jokul@email.com",
      "virtualAccountPhone": "6281828384858",
      "sourceAccountNo": "1234567890",
      "sourceAccountType": "S",
      "trxId": "abcdefgh1234",
      "inquiryRequestId": "abcdef-123456-abcdef",
      "paymentRequestId": "abcdef-123456-abcdef",
      "paidAmount": {
        "value": "12345678.00",
        "currency": "IDR"
      },
      "paidBills": "95000",
      "totalAmount": {
        "value": "12345678.00",
        "currency": "IDR"
      },
      "trxDateTime": "20201231T235959Z",
    }
  ]
}
```

```

"referenceNo":"123456789012345",
"journalNum":"123456",
"paymentType":1,
"flagAdvise":"Y",
"billDetails":[
  {
    "billCode":"01",
    "billNo":"123456789012345678",
    "billName":"Bill A for Jan",
    "billShortName":"Bill A",
    "billDescription":{
      "english":"Maintenance",
      "indonesia":"Pemeliharaan"
    },
    "billSubCompany":"00001",
    "billAmount":{
      "value":"12345678.00",
      "currency":"IDR"
    },
    "additionalInfo":{

    },
    "status":"00",
    "reason":{
      "english":"Success",
      "indonesia":"Sukses"
    }
  }
],
"freeTexts":[
  {
    "english":"Free text",
    "indonesia":"Tulisan bebas"
  }
],
"additionalInfo":{

}
]
}

```



### 4.2.3. API Transaction Status Inquiry

#### Sequence Diagram

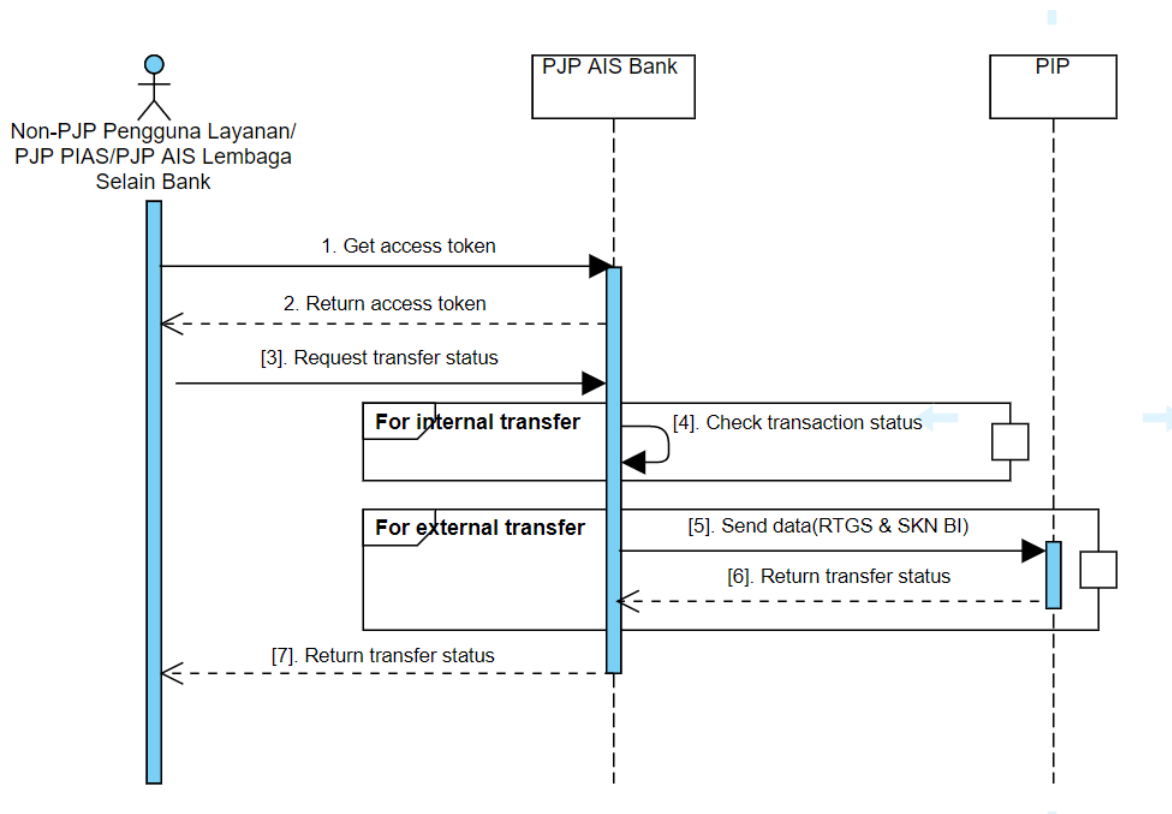

Sequence Diagram API Transaction Status Inquiry

#### Informasi Umum

<b>Service Code</b>	36
<b>Name</b>	API Transaction Status Inquiry
<b>Version</b>	1.0
<b>HTTP Method</b>	POST
<b>Path</b>	.../{version}/transfer/status

#### Request Body

<i>Parameter</i>	<i>Data Type</i>	<i>Mandatory</i>	<i>Length</i>	<i>Description</i>	<i>Example</i>
originalPartnerReferenceNo	String	O	64	Original transaction identifier on	202010290000 0000000001

<b>Parameter</b>	<b>Data Type</b>	<b>Mandatory</b>	<b>Length</b>	<b>Description</b>	<b>Example</b>
				service consumer system	
originalReferenceNo	String	O	64	Original transaction identifier on service provider system	20201029777 70000000009
originalExternalId	String	O	32	Original External-ID on header message	30443786930 72272646328 0097920912
serviceCode	String	M	2	Transaction type indicator. Service code of the transaction that needs to be checked (original transaction).	17
transactionDate	String	O	25	Transaction date : ISO 8601 YYYY-MM-DDThh:mm:ss	2019-07-03T12:08:56+07:00
amount	Object	O			
value	String	M	16,2	Transaction Amount. Nominal inputted by	12345678.00

<b>Parameter</b>	<b>Data Type</b>	<b>Mandatory</b>	<b>Length</b>	<b>Description</b>	<b>Example</b>
				Customer with 2 decimal	
currency	String	M	3	Currency (ISO 4217)	IDR
additionalInfo	Object	O	N/A	Additional information for custom use that are not provided by SNAP	{ "deviceId": "12345679237", "channel": "mobilephone"}

### Response Body

<b>Parameter</b>	<b>Data Type</b>	<b>Mandatory</b>	<b>Length</b>	<b>Description</b>	<b>Example</b>
responseCode	String	M	7	Response code	2003600
responseMessage	String	M	150	Response description	Successful
originalReferenceNo	String	C	64	Original transaction identifier on service provider system.  Must be filled upon successful original transaction	20201029777 70000000009

<b>Parameter</b>	<b>Data Type</b>	<b>Mandatory</b>	<b>Length</b>	<b>Description</b>	<b>Example</b>
originalPartnerReferenceNo	String	O	64	Original transaction identifier on service consumer system	20201029000 00000000001
originalExternalId	String	O	32	Original External-ID on header message	30443786930 72272646328 0097920912
serviceCode	String	M	2	Transaction type indicator. Service code of the transaction that needs to be checked (original transaction).	17
transactionDate	String	O	25	Transaction date : ISO 8601 YYYY-MM-DDThh:mm:ss	2019-07-03T12:08:56+07:00
amount	Object	O			
value	String	M	16,2	Net amount of the transaction. If it's IDR then value includes	12345678.00

<b>Parameter</b>	<b>Data Type</b>	<b>Mandatory</b>	<b>Length</b>	<b>Description</b>	<b>Example</b>
				2 decimal digits. e.g. IDR 10.000,- will be placed with 10000.00	
currency	String	M	3	Currency (ISO 4217)	IDR
beneficiaryAccountNo	String	M	34	Beneficiary Account	888801000003301
beneficiaryBankCode	String	O	8	Beneficiary Bank Code	002
currency	String	O	3	Currency Type	IDR
previousResponseCode	String	O	7	Previous Response Code Transaction Status	2001700
referenceNumber	String	M	30	Reference Number dari Sistem	10052019
sourceAccountNo	String	M	19	Source Account	888801000157508
transactionId	String	O	8	Transaction ID unique per 90 days (using UTC+07)	10052019

<b>Parameter</b>	<b>Data Type</b>	<b>Mandatory</b>	<b>Length</b>	<b>Description</b>	<b>Example</b>
				Time Zone). Format: Must be 8 in length.	
latestTransaction Status	String	M	2	<b>00</b> = Success <b>01</b> = Initiated <b>02</b> = Paying <b>03</b> = Pending <b>04</b> = Refunded <b>05</b> = Canceled <b>06</b> = Failed <b>07</b> = Not found	00
transactionSta tusDesc	String	O	50	Description status transaction	Success
additionalInfo	Object	O	N/A	Additional information for custom use that are not provided by SNAP	{ "deviceId": "12345679237", "channel": "mobilephone"}

### Contoh Request

```

POST .../v1.0/transfer/status HTTP/1.2
Content-type: application/json
Authorization: Bearer
gp9HjjEj813Y9JGoqwOeOPWbnt4CUpvIJbU1mMU4a11MNDZ7Sg5u9a"
Authorization-Customer: Bearer
fa8sjjEj813Y9JGoqwOeOPWbnt4CUpvIJbU1mMU4a11MNDZ7Sg5u9a"
X-TIMESTAMP: 2020-12-21T14:56:11+07:00
X-SIGNATURE:
85be817c55b2c135157c7e89f52499bf0c25ad6eebe04a986e8c862561b19a5
X-ORIGIN: www.hostname.com
X-PARTNER-ID: 82150823919040624621823174737537
X-EXTERNAL-ID: 41807553358950093184162180797837

```

X-IP-ADDRESS: 172.24.281.24  
X-DEVICE-ID: 09864ADCASA  
X-LATITUDE: -6.1617169  
X-LONGITUDE: 106.6643946  
CHANNEL-ID: 95221

```
{
  "originalPartnerReferenceNo":"202010290000000000000001",
  "originalReferenceNo":"202010297777000000000009",
  "originalExternalId":"30443786930722726463097920912",
  "serviceCode":"17",
  "transactionDate":"2019-07-03T12:08:56+07:00",
  "amount":{
    "value":"12345678.00",
    "currency":"IDR"
  },
  "additionalInfo":{
    "deviceId":"12345679237",
    "channel":"mobilephone"
  }
}
```

### Contoh Response

Content-type: application/json  
X-TIMESTAMP: 2020-12-21T14:36:19+07:00  
X-SIGNATURE:  
85be8171923ac135157c7e89f52499bf0c25ad6eeeb04a986e8c862561b19a5

```
{
  "responseCode":"2003600",
  "responseMessage":"Successful",
  "originalReferenceNo":"202010297777000000000009",
  "originalPartnerReferenceNo":"202010290000000000000001",
  "originalExternalId":"30443786930722726463097920912",
  "serviceCode":"17",
  "transactionDate":"2019-07-03T12:08:56+07:00",
  "amount":{
    "value":"12345678.00",
    "currency":"IDR"
  },
  "beneficiaryAccountNo":"888801000003301",
  "beneficiaryBankCode":"002",
  "currency":"IDR",
  "previousResponseCode":"2001700",
  "referenceNumber":"10052019",
  "sourceAccountNo":"888801000157508",
  "transactionId":"10052019",
  "latestTransactionStatus":"00",
  "transactionStatusDesc":"success",
}
```

```
"additionalInfo":{  
  "deviceId":"12345679237",  
  "channel":"mobilephone"  
}  
}
```



### 4.3. SPESIFIKASI API TRANSFER KREDIT

#### 4.3.1. API Customer Top Up

##### a. Account Inquiry

##### Sequence Diagram

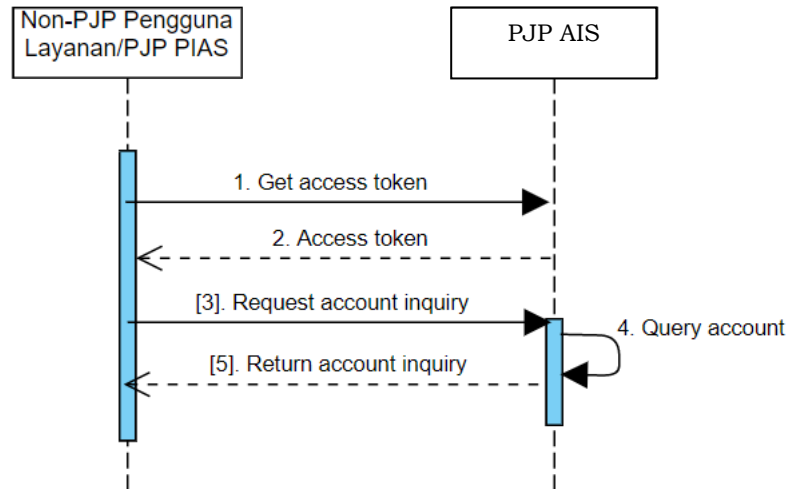

Sequence Diagram API Account Inquiry - Customer Top Up

##### Informasi Umum

<b>Service Code</b>	37
<b>Name</b>	API Account Inquiry - Customer Top Up
<b>Version</b>	1.0
<b>HTTP Method</b>	POST
<b>Path</b>	.../{version}/emoney/account-inquiry

##### Request Body

<i>Parameter</i>	<i>Data Type</i>	<i>Mandatory</i>	<i>Length</i>	<i>Description</i>	<i>Example</i>
partnerReferenceNo	String	O	64	Transaction identifier on service consumer system	2020102900 0000000000 01

<b>Parameter</b>	<b>Data Type</b>	<b>Mandatory</b>	<b>Length</b>	<b>Description</b>	<b>Example</b>
customerNumber	String	C	32	Customer Account Number.  Must be filled if customer's token (Token B2B2C) is null	6281388370  001
amount	Object	M			
value	String	M	16,2	Net amount of the transaction. If it's IDR then value includes 2 decimal digits. e.g. IDR 10.000,- will be placed with 10000.00	12345678.00
currency	String	M	3	Currency (ISO 4217)	IDR
transactionDate	String	O	25	Format Transaction date : (ISO 8601) YYYY-MM-DDThh:mm:ss	2020-12-21T14:56:11+07:00
additionalInfo	Object	O	N/A	Additional information for custom use that	{"deviceId": "12345679237",

<b>Parameter</b>	<b>Data Type</b>	<b>Mandatory</b>	<b>Length</b>	<b>Description</b>	<b>Example</b>
				are not provided by SNAP	"channel": "mobilephone"}

### Response Body

<b>Parameter</b>	<b>Data Type</b>	<b>Mandatory</b>	<b>Length</b>	<b>Description</b>	<b>Example</b>
responseCode	String	M	7	Response code	2003700
responseMessage	String	M	150	Response description	Successful
referenceNo	String	O	64	Transaction identifier on service provider system.	20201029777 70000000009
partnerReferenceNo	String	O	64	Transaction identifier on service consumer system	20201029000 00000000001
sessionId	String	O	25	Session ID transaction	883737GHY8 839
customerNumber	String	C	64	Customer Account Number Rule of mask for UI XXXXXXXXXX18 57	62873773882 72

<b>Parameter</b>	<b>Data Type</b>	<b>Mandatory</b>	<b>Length</b>	<b>Description</b>	<b>Example</b>
				Must be filled if user's access token (Token B2B2C) is null	
customerName	String	M	255	Unmasked customer account name	John Doe
customerMonthlyInLimit	Number	O	17	Customer monthly cashin limit	10000000
minAmount	Object	O			
value	String	M	16,2	Net amount of the transaction. If it's IDR then value includes 2 decimal digits. e.g. IDR 10.000,- will be placed with 10000.00	10000.00
currency	String	M	3	Currency (ISO 4217)	IDR
maxAmount	Object	O			
value	String	M	16,2	Net amount of the transaction. If it's IDR then value includes 2 decimal digits.	10000.00

<b>Parameter</b>	<b>Data Type</b>	<b>Mandatory</b>	<b>Length</b>	<b>Description</b>	<b>Example</b>
				e.g. IDR 10.000,- will be placed with 10000.00	
currency	<i>String</i>	M	3	Currency (ISO 4217)	IDR
amount	<i>Object</i>	O			
value	<i>String</i>	M	16,2	Net amount of the transaction. If it's IDR then value includes 2 decimal digits. e.g. IDR 10.000,- will be placed with 10000.00	10000.00
currency	<i>String</i>	M	3	Currency (ISO 4217)	IDR
feeAmount	<i>Object</i>	O			
value	<i>String</i>	M	16,2	Net amount of the transaction. If it's IDR then value includes 2 decimal digits. e.g. IDR 10.000,- will be placed with 10000.00	10000.00

<b>Parameter</b>	<b>Data Type</b>	<b>Mandatory</b>	<b>Length</b>	<b>Description</b>	<b>Example</b>
currency	String	M	3	Currency (ISO 4217)	IDR
feeType	String	O	25	Fee type	Admin fee
additionalInfo	Object	O	N/A	Additional information for custom use that are not provided by SNAP	{"deviceId": "12345679237", "channel": "mobilephone"}

### Contoh Request

```
POST .../v1.0/emoney/account-inquiry HTTP/1.2
Content-type: application/json
Authorization: Bearer
gp9HjjEj813Y9JGoqwOeOPWbnt4CUpvIJbU1mMU4a11MNDZ7Sg5u9a"
Authorization-Customer: Bearer
fa8sjjEj813Y9JGoqwOeOPWbnt4CUpvIJbU1mMU4a11MNDZ7Sg5u9a"
X-TIMESTAMP: 2020-12-21T17:02:11+07:00
X-SIGNATURE:
85be817c55b2c135157c7e89f52499bf0c25ad6eebe04a986e8c862561b19a5
ORIGIN: www.hostname.com
X-PARTNER-ID: 82150823919040624621823174737537
X-EXTERNAL-ID: 41807553358950093184162180797837
X-IP-ADDRESS: 172.24.281.24
X-DEVICE-ID: 09864ADCASA
X-LATITUDE: -6.1617169
X-LONGITUDE: 106.6643946
CHANNEL-ID: 95221
```

```
{
  "partnerReferenceNo": "202010290000000000000001",
  "customerNumber": "6287377388272",
  "amount": {
    "value": "12345678.00",
    "currency": "IDR"
  },
  "transactionDate": "2020-12-21T14:56:11+07:00",
  "additionalInfo": {
    "deviceId": "12345679237",
    "channel": "mobilephone"
  }
}
```

```
}
```

## Contoh Response

```
Content-type: application/json  
X-TIMESTAMP: 2020-12-21T17:02:18+07:00
```

```
{  
  "responseCode": "2003700",  
  "responseMessage": "Successful",  
  "referenceNo": "2020102977770000000009",  
  "partnerReferenceNo": "2020102900000000000001",  
  "sessionId": "883737GHY8839",  
  "customerNumber": "6281388370001",  
  "customerName": "John Doe",  
  "customerMonthlyInLimit": "10000000",  
  "minAmount": {  
    "value": "10000.00",  
    "currency": "IDR"  
  },  
  "maxAmount": {  
    "value": "10000.00",  
    "currency": "IDR"  
  },  
  "amount": {  
    "value": "10000.00",  
    "currency": "IDR"  
  },  
  "feeAmount": {  
    "value": "10000.00",  
    "currency": "IDR"  
  },  
  "feeType": "Admin fee",  
  "additionalInfo": {  
    "deviceId": "12345679237",  
    "channel": "mobilephone"  
  }  
}
```

## b. Customer Top Up Sequence Diagram

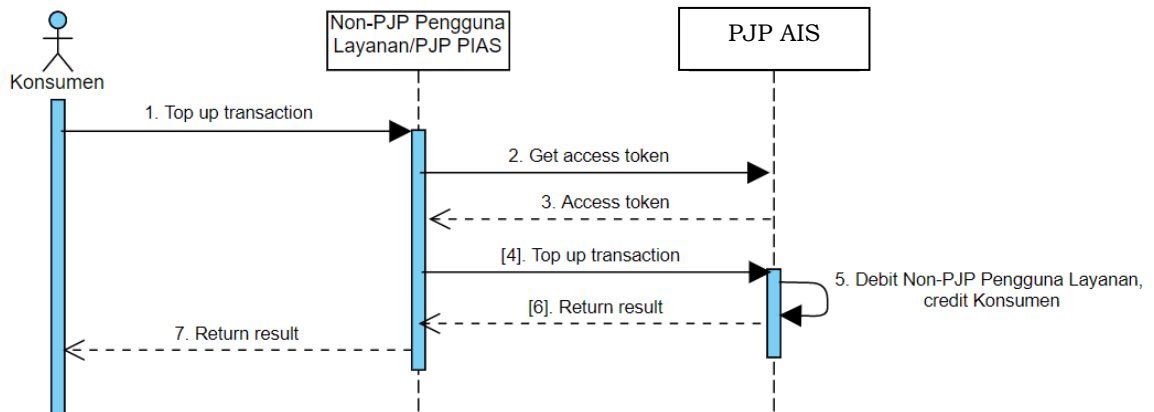

Sequence Diagram API Customer Top Up

### Informasi Umum

<b>Service Code</b>	38
<b>Name</b>	API Customer Top Up
<b>Version</b>	1.0
<b>HTTP Method</b>	POST
<b>Path</b>	.../{version}/emoney/topup

### Request Body

<b>Parameter</b>	<b>Data Type</b>	<b>Mandatory</b>	<b>Length</b>	<b>Description</b>	<b>Example</b>
partnerReferenceNo	String	M	64	Transaction identifier on service consumer system	20201029000000000001
customerNumber	String	O	32	Customer Account number	6281773628883



<b>Parameter</b>	<b>Data Type</b>	<b>Mandatory</b>	<b>Length</b>	<b>Description</b>	<b>Example</b>
customerName	String	O	255	Customer Account name	John Doe
amount	Object	O			
value	String	M	16,2	Net amount of the transaction. If it's IDR then value includes 2 decimal digits. e.g. IDR 10.000,- will be placed with 10000.00	12345678.00
currency	String	M	3	Currency (ISO 4217)	IDR
feeAmount	Object	O			
value	String	M	16,2	Transaction fee	12345678.00
currency	String	M	3	Currency (ISO 4217)	IDR
transactionDate	String	O	25	Format Transaction date: (ISO 8601) YYYY-MM-DDThh:mm:ss	2020-12-21T17:01:11+07:00
sessionId	String	O	25	Invoice transaction ID	883737GHY8839
categoryId	Number	O	10	Category ID	6
notes	string	O	255	Transaction noted	Notes test
additionalInfo	Object	O	N/A	Additional information for	{"deviceId": "12345679237"}

<b>Parameter</b>	<b>Data Type</b>	<b>Mandatory</b>	<b>Length</b>	<b>Description</b>	<b>Example</b>
				custom use that are not provided by SNAP	, "channel": "mobilephone"};

### Response Body

<b>Parameter</b>	<b>Data Type</b>	<b>Mandatory</b>	<b>Length</b>	<b>Description</b>	<b>Example</b>
responseCode	String	M	7	Response code	2003800
responseMessage	String	M	150	Response description	Successful
referenceNo	String	C	64	Transaction identifier on service provider system.  Must be filled upon successful transaction	2020102977 7700000000 09
partnerReferenceNo	String	O	64	Transaction identifier on service consumer system	2020102900 0000000000 01
sessionId	String	O	25	Transaction invoice ID	883737GHY8 839
customerNumber	String	O	64	Customer account number	6281873663 63
amount	Object	O			

<b>Parameter</b>	<b>Data Type</b>	<b>Mandatory</b>	<b>Length</b>	<b>Description</b>	<b>Example</b>
value	String	M	16,2	Net amount of the transaction. If it's IDR then value includes 2 decimal digits. e.g. IDR 10.000,- will be placed with 10000.00	12345678.00
currency	String	M	3	Currency (ISO 4217)	IDR
additionalInfo	Object	O	N/A	Additional information for custom use that are not provided by SNAP	{"deviceId": "12345679237", "channel": "mobilephone"}

### Contoh Request

```

POST .../v1.0/emoney/topup HTTP/1.2
Content-type: application/json
Authorization: Bearer
gp9HjjEj813Y9JGoqwOeOPWbnt4CUpvIJbU1mMU4a11MNDZ7Sg5u9a"
Authorization-Customer: Bearer
fa8sjjEj813Y9JGoqwOeOPWbnt4CUpvIJbU1mMU4a11MNDZ7Sg5u9a"
X-TIMESTAMP: 2020-12-21T17:07:11+07:00
X-SIGNATURE:
85be817c55b2c135157c7e89f52499bf0c25ad6eebe04a986e8c862561b19a5
ORIGIN: www.hostname.com
X-PARTNER-ID: 82150823919040624621823174737537
X-EXTERNAL-ID: 41807553358950093184162180797837
X-IP-ADDRESS: 172.24.281.24
X-DEVICE-ID: 09864ADCASA
X-LATITUDE: -6.1617169
X-LONGITUDE: 106.6643946
CHANNEL-ID: 95221

```

```
{
```

```
"partnerReferenceNo": "202010290000000000000001",
"customerNumber": "6281773628883",
"customerName": "John Doe",
"amount": {
  "value": "12345678.00",
  "currency": "IDR"
},
"feeAmount": {
  "value": "12345678.00",
  "currency": "IDR"
},
"transactionDate": "2020-12-21T17:01:11+07:00",
"sessionId": "883737GHY8839",
"categoryId": "6",
"notes": "notes test",
"additionalInfo": {
  "deviceId": "12345679237",
  "channel": "mobilephone"
}
}
```

### Contoh Response

Content-type: application/json  
X-TIMESTAMP: 2020-12-21T14:36:19+07:00

```
{
  "responseCode": "2003800",
  "responseMessage": "Successful",
  "referenceNo": "202010297777000000000009",
  "partnerReferenceNo": "202010290000000000000001",
  "sessionId": "883737GHY8839",
  "customerNumber": "628187366363",
  "amount": {
    "value": "12345678.00",
    "currency": "IDR"
  },
  "additionalInfo": {
    "deviceId": "12345679237",
    "channel": "mobilephone"
  }
}
```

### c. Customer Top Up Inquiry Status

#### Sequence Diagram

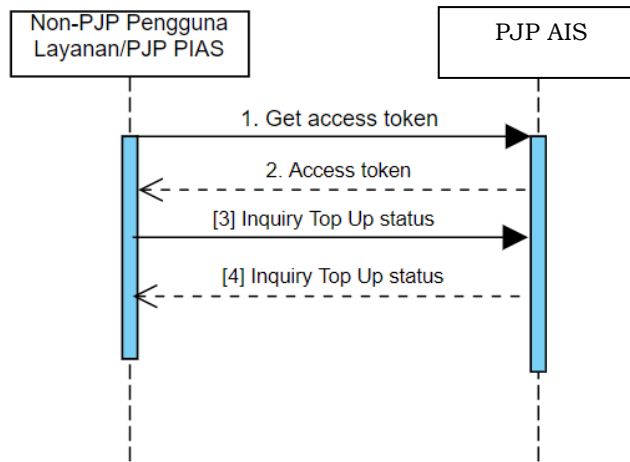

Sequence Diagram API Customer Top Up Inquiry Status

#### Informasi Umum

<b>Service Code</b>	39
<b>Name</b>	API Customer Top Up Inquiry Status
<b>Version</b>	1.0
<b>HTTP Method</b>	POST
<b>Path</b>	.../{version}/emoney/topup-status

#### Request Body

<b>Parameter</b>	<b>Data Type</b>	<b>Mandatory</b>	<b>Length</b>	<b>Description</b>	<b>Example</b>
originalPartnerReferenceNo	String	O	64	Transaction identifier/reference generated by partner.	2021072342 3580894758 92734
originalReferenceNo	String	O	64	Transaction identifier/reference generated	2021072342 3580894758 92091

<b>Parameter</b>	<b>Data Type</b>	<b>Mandatory</b>	<b>Length</b>	<b>Description</b>	<b>Example</b>
				by PJP AIS Selain Bank.	
originalExternal Id	String	O	64	Original X- EXTERNAL-ID from top up request.	2ads-2da- d23dasd- 21dadjoiq- 23ij4oinfoen
serviceCode	String	M	2	Transaction type indicator. Service code of the transaction that needs to be checked (original transaction).	38
additionalInfo	Object	O	N/A	Additional information for custom use that are not provided by SNAP	{"deviceId": "12345679237", "channel": "mobilephone"}

### Response Body

<b>Parameter</b>	<b>Data Type</b>	<b>Mandatory</b>	<b>Length</b>	<b>Description</b>	<b>Example</b>
responseCode	String	M	7	Response code	2003900
responseMessage	String	M	150	Response description	Successful
originalPartner ReferenceNo	String	O	64	Transaction identifier/refere	20210723423 58089475892 734

<b>Parameter</b>	<b>Data Type</b>	<b>Mandatory</b>	<b>Length</b>	<b>Description</b>	<b>Example</b>
				nce generated by partner.	
originalReferenceNo	String	O	64	Transaction identifier/reference generated by PJP AIS Selain Bank.	20210723423 58089475892 091
originalExternalId	String	O	64	Original X-EXTERNAL-ID from top up request.	2ads-2da- d23dasd- 21dadjoiq- 23ij4oinfoen
serviceCode	String	M	2	Transaction type indicator. Service code of the transaction that needs to be checked (original transaction).	38
amount	Object	O			
value	String	M	16,2	Net amount of the transaction. If it's IDR then value includes 2 decimal digits. e.g. IDR 10.000,- will be placed with 10000.00	12345678.00
currency	String	M	3	Currency	IDR

<b>Parameter</b>	<b>Data Type</b>	<b>Mandatory</b>	<b>Length</b>	<b>Description</b>	<b>Example</b>
				(ISO 4217)	
latestTransactionStatus	String	M	2	<b>00</b> = Success <b>01</b> = Initiated <b>02</b> = Paying <b>03</b> = Pending <b>04</b> = Refunded <b>05</b> = Canceled <b>06</b> = Failed <b>07</b> = Not found	00
transactionStatusDesc	String	O	50	Description status transaction	Success
additionalInfo	Object	O	N/A	Additional information for custom use that are not provided by SNAP	{ "deviceId": "12345679237", "channel": "mobilephone"}

### Contoh Request

```

POST .../v1.0/emoney/topup-status HTTP/1.2
Content-type: application/json
Authorization: Bearer
gp9HjjEj813Y9JGoqwOeOPWbnt4CUpvIJbU1mMU4a11MNDZ7Sg5u9a"
Authorization-Customer: Bearer
fa8sjjEj813Y9JGoqwOeOPWbnt4CUpvIJbU1mMU4a11MNDZ7Sg5u9a"
X-TIMESTAMP: 2020-12-21T17:07:11+07:00
X-SIGNATURE:
85be817c55b2c135157c7e89f52499bf0c25ad6eebe04a986e8c862561b19a5
ORIGIN: www.hostname.com
X-PARTNER-ID: 82150823919040624621823174737537
X-EXTERNAL-ID: 41807553358950093184162180797837
X-IP-ADDRESS: 172.24.281.24
X-DEVICE-ID: 09864ADCASA
X-LATITUDE: -6.1617169

```



X-LONGITUDE: 106.6643946  
CHANNEL-ID: 95221

```
{
  "originalPartnerReferenceNo": "2021072342358089475892734",
  "originalReferenceNo": "2021072342358089475892091",
  "originalExternalId": "2ads-2da-d23dasd-21dadjoiq-
23ij4oinfoen",
  "serviceCode": "38",
  "additionalInfo": {
    "deviceId": "12345679237",
    "channel": "mobilephone"
  }
}
```

### Contoh Response

Content-type: application/json  
X-TIMESTAMP: 2020-12-21T14:36:19+07:00

```
{
  "responseCode": "2003900",
  "responseMessage": "Successful",
  "originalPartnerReferenceNo": "2021072342358089475892734",
  "originalReferenceNo": "2021072342358089475892091",
  "originalExternalId": "2ads-2da-d23dasd-21dadjoiq-
23ij4oinfoen",
  "serviceCode": "38",
  "amount": {
    "value": 12345678.00",
    "currency": "IDR"
  },
  "latestTransactionStatus": "00"
  "transactionStatusDesc": "success",
  "additionalInfo": {
    "deviceId": "12345679237",
    "channel": "mobilephone"
  }
}
```

### 4.3.2. API Bulk Cash In

#### a. Submit Bulk

#### Sequence Diagram

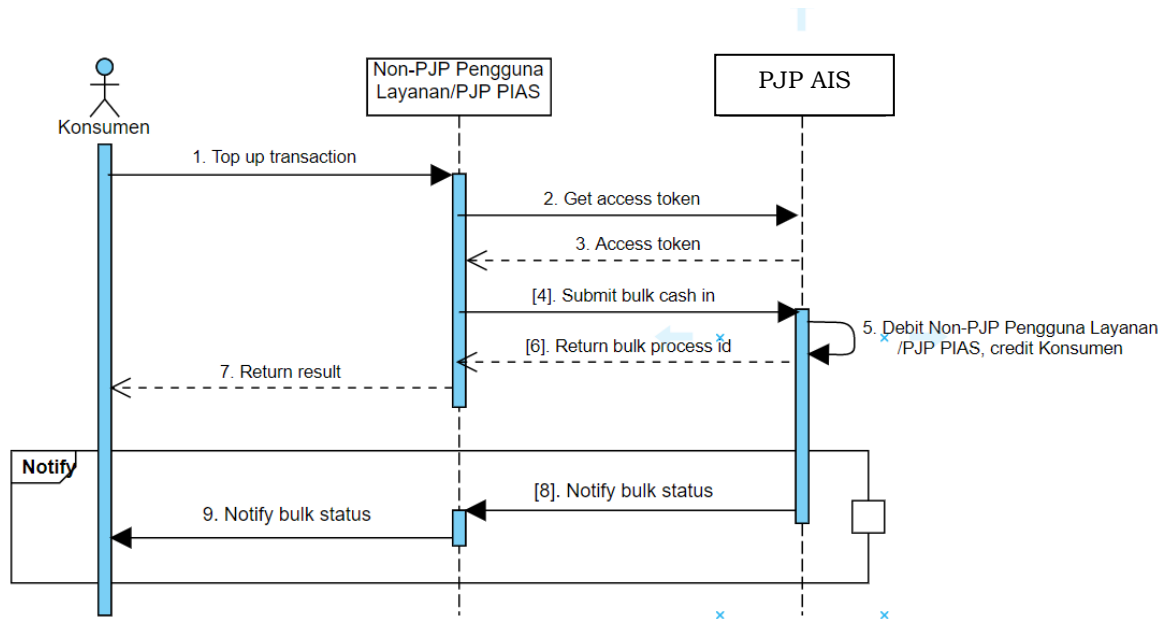

Sequence Diagram API Submit Bulk Cash In

#### Informasi Umum

<b>Service Code</b>	40
<b>Name</b>	API Submit Bulk Cash In
<b>Version</b>	1.0
<b>HTTP Method</b>	POST
<b>Path</b>	.../{version}/emoney/bulk-cashin-payment

#### Request Body

<b>Parameter</b>	<b>Data Type</b>	<b>Mandatory</b>	<b>Length</b>	<b>Description</b>	<b>Example</b>
partnerBulkId	String	0	64	Bulk transaction identifier on service consumer (bulk transaction sender) system	2020102900 0000000000 01

<b>Parameter</b>	<b>Data Type</b>	<b>Mandatory</b>	<b>Length</b>	<b>Description</b>	<b>Example</b>
transactionDate	String	M	25	Format transaction date : (ISO 8601) YYYY-MM-DDThh:mm:ss	2019-07-03T12:08:56+07:00
currency	String	O	3	Currency	IDR
bulkObject	Array of Object				
accountNumber	String	M	64	Customer Account Number	6281388370001
accountName	String	O	30	Customer Name	Kades
amount	Object	O			
value	String	M	16,2	Net amount of the transaction. If it's IDR then value includes 2 decimal digits. e.g. IDR 10.000,- will be placed with 10000.00	12345678.00
currency	String	M	3	Currency (ISO 4217)	IDR

<i>Parameter</i>	<i>Data Type</i>	<i>Mandatory</i>	<i>Length</i>	<i>Description</i>	<i>Example</i>
partnerReferenceNo	String	M	64	Individual transaction identifier on service consumer (bulk transaction sender) system	2020102900 0000000009 90
additionalInfo	Object	O	N/A	Additional information	{"deviceId": "12345679237", "channel": "mobilephone"}
feeType	String	O	25	To whom the fee will be charged  <b>OUR</b> = Fee is charged to the sender (default) <b>BEN</b> = Fee is charged to the recipient <b>SHA   1000</b> = Fee is shared between sender and recipient, with sender is charged Rp 1.000,00 and the recipient	OUR

<b>Parameter</b>	<b>Data Type</b>	<b>Mandatory</b>	<b>Length</b>	<b>Description</b>	<b>Example</b>
				will be charged the rest	
additionalInfo	Object	O	N/A	Additional information for custom use that are not provided by SNAP	{"deviceId": "12345679237", "channel": "mobilephone"}

### Response Body

<b>Parameter</b>	<b>Data Type</b>	<b>Mandatory</b>	<b>Length</b>	<b>Description</b>	<b>Example</b>
responseCode	String	M	7	Response code	2004000
responseMessage	String	M	150	Response description	Successful
bulkId	String	M	64	Transaction identifier on service provider (Bulk transaction processing) system	2020102977 7700000000 09
partnerBulkId	String	O	64	Transaction identifier on service consumer (Bulk transaction sender) system	2020102900 0000000000 01
additionalInfo	Object	O	N/A	Additional information for custom use that are not provided by SNAP	{"deviceId": "12345679237", "channel": "mobilephone"}

## Contoh Request

```
POST .../v1.0/emoney/bulk-cashin-payment HTTP/1.2
Content-type: application/json
Authorization: Bearer
gp9HjjEj813Y9JGoqwOeOPWbnt4CUpvIJbU1mMU4a11MNDZ7Sg5u9a"
Authorization-Customer: Bearer
fa8sjjEj813Y9JGoqwOeOPWbnt4CUpvIJbU1mMU4a11MNDZ7Sg5u9a"
X-TIMESTAMP: 2020-12-21T17:01:11+07:00
X-SIGNATURE:
85be817c55b2c135157c7e89f52499bf0c25ad6eebe04a986e8c862561b19a5
ORIGIN: www.hostname.com
X-PARTNER-ID: 82150823919040624621823174737537
X-EXTERNAL-ID: 41807553358950093184162180797837
X-IP-ADDRESS: 172.24.281.24
X-DEVICE-ID: 09864ADCASA
X-LATITUDE: -6.1617169
X-LONGITUDE: 106.6643946
CHANNEL-ID: 95221
```

```
{
  "partnerBulkId": "2020102900000000000001",
  "transactionDate": "2019-07-03T12:08:56-07:00",
  "currency": "IDR",
  "bulkObject" : {
    "accountNumber": "6281388370001",
    "accountName": "Kades",
    "amount": {
      "value": "12345678.00",
      "currency": "IDR"
    },
    "partnerReferenceNo": "2020102900000000000990",
    "additionalInfo": {
      "deviceId": "12345679237",
      "channel": "mobilephone"
    }
  },
  "feeType": "OUR",
  "additionalInfo": {
    "deviceId": "12345679237",
    "channel": "mobilephone"
  }
}
```

## Contoh Response

```
Content-type: application/json
X-TIMESTAMP: 2020-12-21T17:01:17+07:00
```

```
{
  "responseCode": "2004000",
  "responseMessage": "Successful",
  "bulkId": "20201029777700000000009",
  "partnerBulkId ": "20201029000000000000001",
  "additionalInfo": {
    "deviceId": "12345679237",
    "channel": "mobilephone"
  }
}
```

## b. Notify Bulk

### Informasi Umum

<b>Service Code</b>	41
<b>Name</b>	API Bulk Cash In Notification
<b>Version</b>	1.0
<b>HTTP Method</b>	POST
<b>Path</b>	.../{version}/emoney/bulk-cashin-notify

### Request Body

<i>Parameter</i>	<i>Data Type</i>	<i>Mandatory</i>	<i>Length</i>	<i>Description</i>	<i>Example</i>
bulkId	String	M	64	Transaction identifier on bulk transaction processing system	2020102977 7700000000 09
partnerBulkId	String	M	64	Transaction identifier on bulk transaction sender system	2020102900 0000000000 01
bulkObject	Array of Objects				
customerNumber	String	M	64	Customer Account Number	6281388370 001
customerName	String	O	30	Customer Name	Kades
amount	Object	O			



<b>Parameter</b>	<b>Data Type</b>	<b>Mandatory</b>	<b>Length</b>	<b>Description</b>	<b>Example</b>
value	String	M	16,2	Net amount of the transaction. If it's IDR then value includes 2 decimal digits. e.g. IDR 10.000,- will be placed with 10000.00	12345678.00
currency	String	M	3	Currency (ISO 4217)	IDR
referenceNo	String	M	64	Individual transaction identifier on bulk transaction processing system	2020102977 7700000000 09
partnerReferenceNo	String	M	64	Individual transaction identifier on bulk transaction sender system	2020102900 0000000009 90
responseCode	String	M	7	Response Code	2004000
responseMessage	String	M	150	Response description	Successful

<b>Parameter</b>	<b>Data Type</b>	<b>Mandatory</b>	<b>Length</b>	<b>Description</b>	<b>Example</b>
additionalInfo	Object	O	N/A	Additional information for custom use on each bulk object	<pre>{"deviceId": "12345679237", "channel": "mobilephone"}</pre>
additionalInfo	Object	O	N/A	Additional information for custom use that are not provided by SNAP	<pre>{ "deviceId": "12345679237", "channel": "mobilephone" }</pre>

### Response Body

<b>Parameter</b>	<b>Data Type</b>	<b>Mandatory</b>	<b>Length</b>	<b>Description</b>	<b>Example</b>
responseCode	String	M	7	Response code	2004100
responseMessage	String	M	150	Response description	Successful
bulkId	String	M	64	Transaction identifier on bulk transaction processing system	2020102977 7700000000 09
partnerBulkId	String	M	64	Transaction identifier on bulk transaction sender system	2020102900 0000000000 01

<b>Parameter</b>	<b>Data Type</b>	<b>Mandatory</b>	<b>Length</b>	<b>Description</b>	<b>Example</b>
additionalInfo	Object	O	N/A	Additional information for custom use that are not provided by SNAP	{ "deviceId": "12345679237", "channel": "mobilephone"}

### Contoh Request

```
POST .../v1.0/emoney/bulk-cashin-notify HTTP/1.2
Content-type: application/json
Authorization: Bearer
gp9HjjEj813Y9JGoqwOeOPWbnt4CUpvIJbU1mMU4a11MNDZ7Sg5u9a"
Authorization-Customer: Bearer
fa8sjjEj813Y9JGoqwOeOPWbnt4CUpvIJbU1mMU4a11MNDZ7Sg5u9a"
X-TIMESTAMP: 2020-12-21T17:07:11+07:00
X-SIGNATURE:
85be817c55b2c135157c7e89f52499bf0c25ad6eebe04a986e8c862561b19a5
ORIGIN: www.hostname.com
X-PARTNER-ID: 82150823919040624621823174737537
X-EXTERNAL-ID: 41807553358950093184162180797837
X-IP-ADDRESS: 172.24.281.24
X-DEVICE-ID: 09864ADCASA
X-LATITUDE: -6.1617169
X-LONGITUDE: 106.6643946
CHANNEL-ID: 95221
```

```
{
  "bulkId": "2020102977770000000009",
  "partnerBulkId": "2020102900000000000001",
  "bulkObject": {
    "customerNumber": "6281388370001",
    "customerName": "Kades",
    "amount": {
      "value": "12345678.00",
      "currency": "IDR"
    },
  },
  "additionalInfo": {
    "deviceId": "12345679237",
    "channel": "mobilephone"
  }
  "referenceNo": "2020102977770000000009",
```

```
        "partnerReferenceNo": "2020102900000000000990",
        "responseCode": "2004100",
        "responseMessage": "Successful"
    },
    "additionalInfo": {
        "deviceId": "12345679237",
        "channel": "mobilephone"
    }
}
```

### Contoh Response

Content-type: application/json  
X-TIMESTAMP: 2020-12-21T17:07:18+07:00

```
{
    "responseCode": "2004100",
    "responseMessage": "Successful",
    "bulkId": "20201029777700000000009",
    "partnerBulkId": "20201029000000000000001",
    "additionalInfo": {
        "deviceId": "12345679237",
        "channel": "mobilephone"
    }
}
```

### 4.3.3. API Transfer to Bank

#### a. Account Inquiry

#### Sequence Diagram

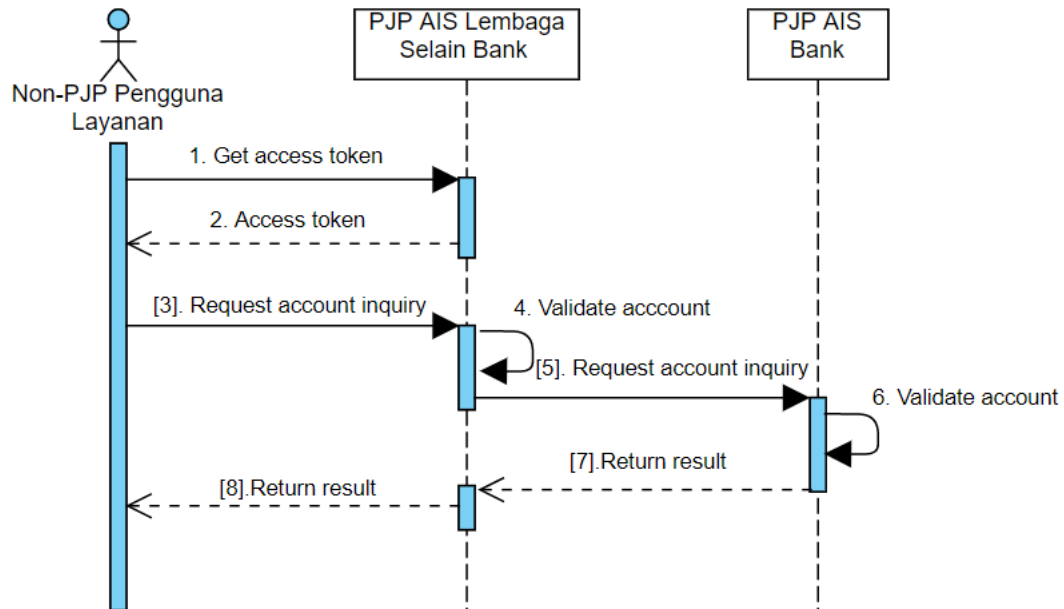

Sequence Diagram API Transfer to Bank-Account Inquiry

#### Informasi Umum

<b>Service Code</b>	42
<b>Name</b>	API Transfer to Bank-Account Inquiry
<b>Version</b>	1.0
<b>HTTP Method</b>	POST
<b>Path</b>	.../{version}/emoney/bank-account-inquiry

#### Request Body

<i>Parameter</i>	<i>Data Type</i>	<i>Mandatory</i>	<i>Length</i>	<i>Description</i>	<i>Example</i>
partnerReferenceNo	String	O	64	Transaction identifier on service consumer system	20201029000000000001

<b>Parameter</b>	<b>Data Type</b>	<b>Mandatory</b>	<b>Length</b>	<b>Description</b>	<b>Example</b>
customerNumber	String	M	32	Customer Account Number	6281388370001
amount	Object	M			
value	String	M	16,2	Net amount of the transaction. If it's IDR then value includes 2 decimal digits. e.g. IDR 10.000,- will be placed with 10000.00	10000.00
currency	String	M	3	Currency (ISO 4217)	IDR
beneficiaryAccountNumber	string	O	32	Destination account number	8377388292
additionalInfo	Object	O	N/A	Additional information for custom use that are not provided by SNAP	{"deviceId": "12345679237", "channel": "mobilephone"}

## Response Body

<b>Parameter</b>	<b>Data Type</b>	<b>Mandatory</b>	<b>Length</b>	<b>Description</b>	<b>Example</b>
responseCode	String	M	7	Response code	2004200
responseMessage	String	M	150	Response description	Successful
referenceNo	String	C	64	Transaction identifier on service provider system.  Must be filled upon successful transaction	2020102977 7700000000 09
partnerReferenceNo	String	O	64	Transaction identifier on service consumer system	2020102900 0000000000 01
accountType	String	O	25	Account type	tabungan
beneficiaryAccountNumber	String	M	32	Beneficiary account number	2452451341
beneficiaryAccountName	String	M	64	Beneficiary account name	John Doe
beneficiaryBankCode	String	O	8	Bank code	003
beneficiaryBankShortName	String	O	25	Bank short	BMRI

<b>Parameter</b>	<b>Data Type</b>	<b>Mandatory</b>	<b>Length</b>	<b>Description</b>	<b>Example</b>
				name	
beneficiaryBank Name	String	O	25	Bank name	Mandiri
amount	Object	M			
value	String	M	16,2	Net amount of the transaction. If it's IDR then value includes 2 decimal digits. e.g. IDR 10.000,- will be placed with 10000.00	10000.00
currency	String	M	3	Currency (ISO 4217)	IDR
sessionId	String	O	25	Session ID	0UYEB77329 002HY
additionalInfo	Object	O	N/A	Additional information for custom use that are not provided by SNAP	{"deviceId": "12345679237", "channel": "mobilephone"}

### Contoh Request

```
POST .../v1.0/emoney/bank-account-inquiry HTTP/1.2
Content-type: application/json
Authorization: Bearer
gp9HjjEj813Y9JGoqwOeOPWbnt4CUpvIJbU1mMU4a11MNDZ7Sg5u9a"
Authorization-Customer: Bearer
fa8sjjEj813Y9JGoqwOeOPWbnt4CUpvIJbU1mMU4a11MNDZ7Sg5u9a"
X-TIMESTAMP: 2020-12-21T17:21:41+07:00
```



X-SIGNATURE:  
85be817c55b2c135157c7e89f52499bf0c25ad6eebe04a986e8c862561b19a5  
ORIGIN: www.hostname.com  
X-PARTNER-ID: 82150823919040624621823174737537  
X-EXTERNAL-ID: 41807553358950093184162180797837  
X-IP-ADDRESS: 172.24.281.24  
X-DEVICE-ID: 09864ADCASA  
X-LATITUDE: -6.1617169  
X-LONGITUDE: 106.6643946  
CHANNEL-ID: 95221

```
{
  "partnerReferenceNo": "2020102900000000000001",
  "customerNumber": "6281388370001",
  "amount": {
    "value": "10000.00",
    "currency": "IDR"
  },
  "beneficiaryAccountNumber": "8377388292",
  "additionalInfo": {
    "deviceId": "12345679237",
    "channel": "mobilephone"
  }
}
```

## Contoh Response

Content-type: application/json  
X-TIMESTAMP: 2020-12-21T17:07:18+07:00

```
{
  "responseCode": "2004200",
  "responseMessage": "Successful",
  "referenceNo": "20201029777700000000009",
  "partnerReferenceNo": "2020102900000000000001",
  "accountType": "tabungan",
  "beneficiaryAccountNumber": "2452451341",
  "beneficiaryAccountName": "John Doe",
  "beneficiaryBankCode": "003",
  "beneficiaryBankShortName": "BMRI",
  "beneficiaryBankName": "Mandiri",
  "amount": {
    "value": "10000.00",
    "currency": "IDR"
  },
  "sessionId": "0UYEB77329002HY",
  "additionalInfo": {
    "deviceId": "12345679237",
  }
}
```

```
    "channel": "mobilephone"  
  }  
}
```

## b. Payment Transaction

### Sequence Diagram

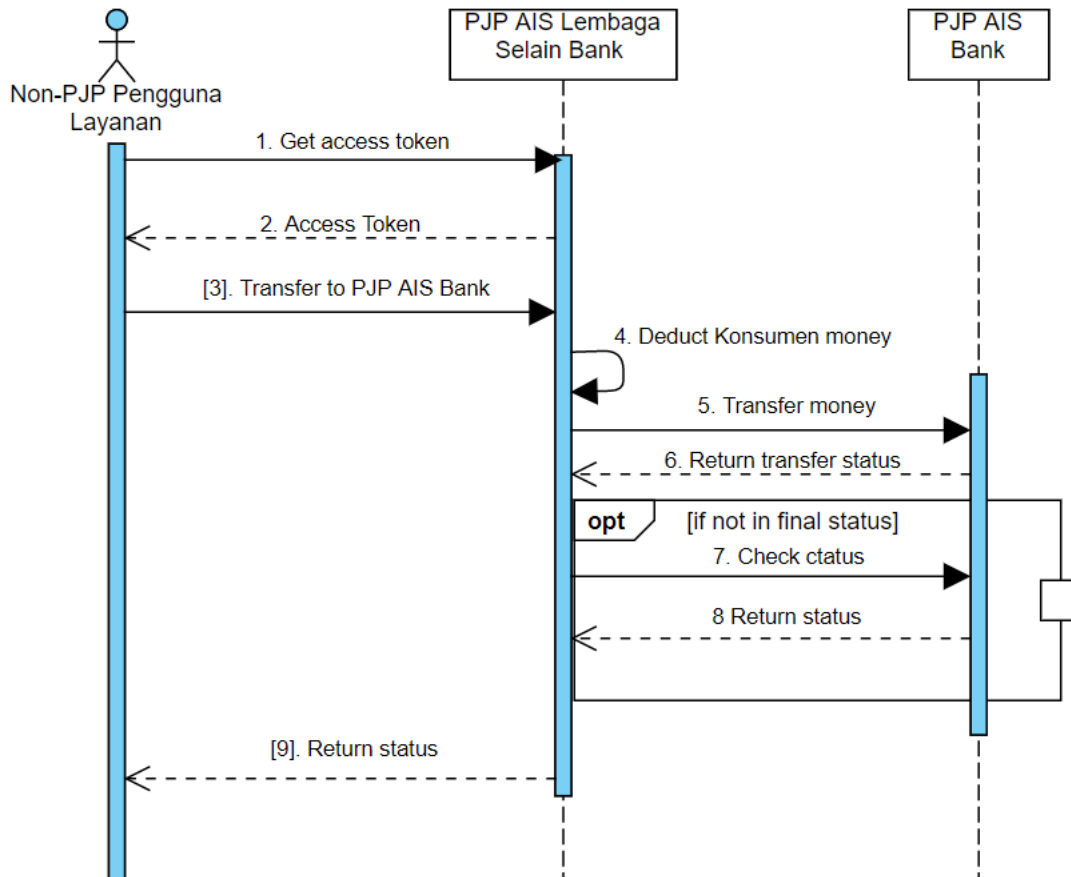

Sequence Diagram API Transfer to Bank-Payment Transaction

### Informasi Umum

<b>Service Code</b>	43
<b>Name</b>	API Transfer to Bank-Payment Transaction
<b>Version</b>	1.0
<b>HTTP Method</b>	POST
<b>Path</b>	.../{version}/emoney/transfer-bank

## Request Body

<i>Parameter</i>	<i>Data Type</i>	<i>Mandatory</i>	<i>Length</i>	<i>Description</i>	<i>Example</i>
partnerReferenceNo	String	M	64	Transaction identifier on service consumer system	20201029000000000001
customerNumber	String	M	32	Customer Account Number	6281388370001
accountType	String	O	25	Account type	tabungan
beneficiaryAccountNumber	String	M	32	Destination account number	8377388292
beneficiaryBankCode	String	O	8	Bank code	002
amount	Object	M			
value	String	M	16,2	Net amount of the transaction. If it's IDR then value includes 2 decimal digits. e.g. IDR 10.000,- will be placed with 10000.00	10000.00
currency	String	M	3	Currency (ISO 4217)	IDR

<b>Parameter</b>	<b>Data Type</b>	<b>Mandatory</b>	<b>Length</b>	<b>Description</b>	<b>Example</b>
sessionId	String	O	25	Session ID	OUYEB77329 002HY
feeType	String	O	25	To whom the fee will be charged  <b>OUR</b> = Fee is charged to the sender (default) <b>BEN</b> = Fee is charged to the recipient <b>SHA   1000</b> = Fee is shared between sender and recipient, with sender is charged Rp 1.000,00 and the recipient will be charged the rest	OUR
additionalInfo	Object	O	N/A	Additional information for custom use that are not provided by SNAP	{"deviceId": "12345679237", "channel": "mobilephone"}

## Response Body

<b>Parameter</b>	<b>Data Type</b>	<b>Mandatory</b>	<b>Length</b>	<b>Description</b>	<b>Example</b>
responseCode	String	M	7	Response code	2004300
responseMessage	String	M	150	Response description	Successful
referenceNo	String	C	64	Transaction identifier on service provider system.  Must be filled upon successful transaction	2020102977 7700000000 09
partnerReferenceNo	String	O	64	Transaction identifier on service consumer system	2020102900 0000000000 01
transactionDate	String	O	25	Format transaction date : (ISO 8601) YYYY-MM-DDThh:mm:ss	2020-12-21T17:48:41+07:00
referenceNumber	String	M	64	Reference number	REF993883
additionalInfo	Object	O	N/A	Additional information for custom use that are not provided by SNAP	{"deviceId": "12345679237", "channel": "mobilephone"}

## Contoh Request

```
POST .../v1.0/emoney/transfer-bank HTTP/1.2
Content-type: application/json
Authorization: Bearer
gp9HjjEj813Y9JGoqwOeOPWbnt4CUpvIJbU1mMU4a11MNDZ7Sg5u9a"
Authorization-Customer: Bearer
fa8sjjEj813Y9JGoqwOeOPWbnt4CUpvIJbU1mMU4a11MNDZ7Sg5u9a"
X-TIMESTAMP: 2020-12-21T17:48:41+07:00
X-SIGNATURE:
85be817c55b2c135157c7e89f52499bf0c25ad6eebe04a986e8c862561b19a5
ORIGIN: www.hostname.com
X-PARTNER-ID: 82150823919040624621823174737537
X-EXTERNAL-ID: 41807553358950093184162180797837
X-IP-ADDRESS: 172.24.281.24
X-DEVICE-ID: 09864ADCASA
X-LATITUDE: -6.1617169
X-LONGITUDE: 106.6643946
CHANNEL-ID: 95221
```

```
{
  "partnerReferenceNo": "202010290000000000000001",
  "customerNumber": "6281388370001",
  "accountType": "tabungan",
  "beneficiaryAccountNumber": "8377388292",
  "beneficiaryBankCode": "002",
  "amount": {
    "value": "10000.00",
    "currency": "IDR"
  },
  "sessionId": "0UYEB77329002HY",
  "additionalInfo": {
    "deviceId": "12345679237",
    "channel": "mobilephone"
  }
}
```

## Contoh Response

```
Content-type: application/json
X-TIMESTAMP: 2020-12-21T17:48:45+07:00
```

```
{
  "responseCode": "2004300",
  "responseMessage": "Successful",
  "referenceNo": "202010297777000000000009",
  "partnerReferenceNo": "202010290000000000000001",
  "transactionDate": "2020-12-21T17:48:41+07:00",
```

```
"referenceNumber": "REF993883",  
"additionalInfo": {  
  "deviceId": "12345679237",  
  "channel": "mobilephone"  
}  
}
```



### 4.3.4. API Transfer to OTC

#### Sequence Diagram

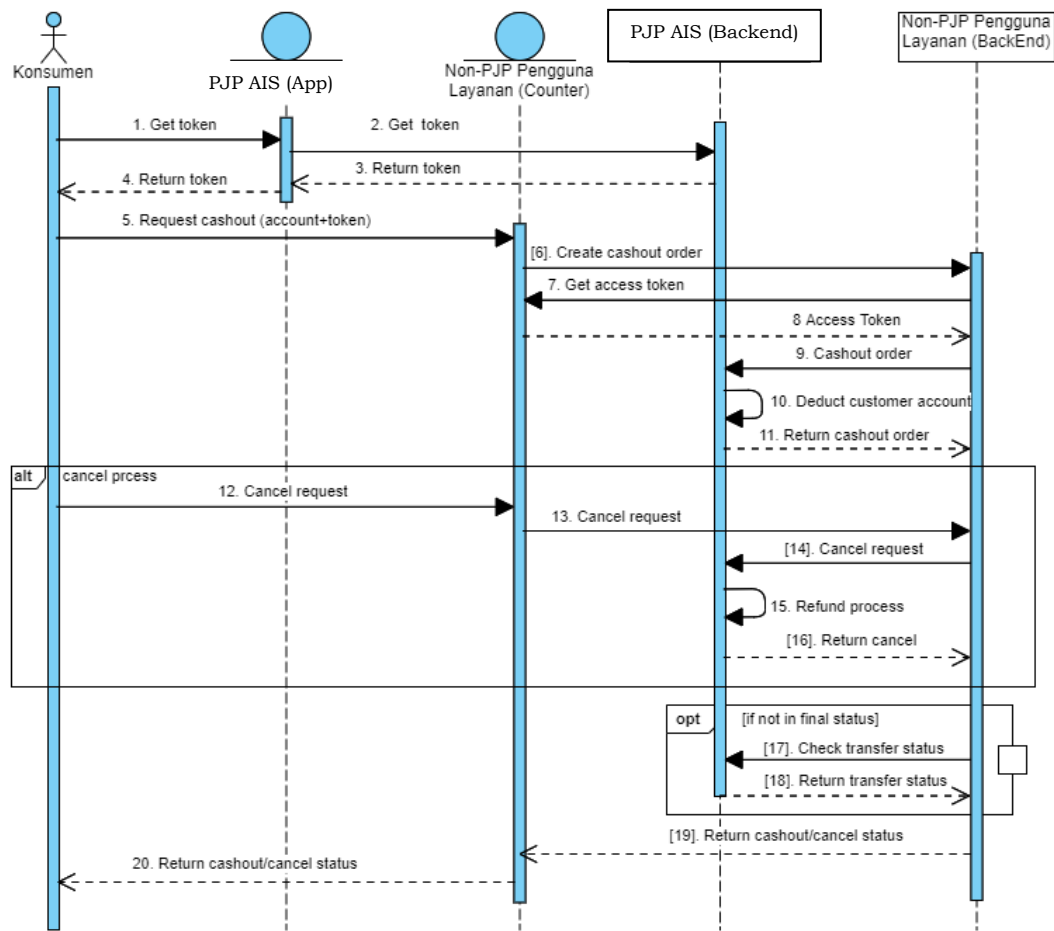

Sequence Diagram API Transfer to OTC

#### a. Create Payment

##### Informasi Umum

<b>Service Code</b>	44
<b>Name</b>	API Transfer to OTC – Create Payment
<b>Version</b>	1.0
<b>HTTP Method</b>	POST
<b>Path</b>	.../{version}/emoney/otc-cashout

## Request Body

<i>Parameter</i>	<i>Data Type</i>	<i>Mandatory</i>	<i>Length</i>	<i>Description</i>	<i>Example</i>
partnerReferenceNo	String	M	64	Transaction identifier on service consumer system	202010290000000000001
customerNumber	String	M	32	Customer Account Number	6281388370001
otp	String	M	8	otp	12345678
amount	Object	M			
value	String	M	16,2	Net amount of the transaction. If it's IDR then value includes 2 decimal digits. e.g. IDR 10.000,- will be placed with 10000.00	10000.00
currency	String	M	3	Currency (ISO 4217)	IDR
feeType	String	O	25	To whom the fee will be charged	OUR

<i>Parameter</i>	<i>Data Type</i>	<i>Mandatory</i>	<i>Length</i>	<i>Description</i>	<i>Example</i>
				<p><b>OUR</b> = Fee is charged to the sender (default)</p> <p><b>BEN</b> = Fee is charged to the recipient</p> <p><b>SHA   1000</b> = Fee is shared between sender and recipient, with sender is charged Rp 1.000,00 and the recipient will be charged the rest</p>	
additionalInfo	Object	O	N/A	Additional information for custom use that are not provided by SNAP	<pre>{   "deviceId":   "12345679237",   "channel":   "mobilephone"} </pre>

### Response Body

<i>Parameter</i>	<i>Data Type</i>	<i>Mandatory</i>	<i>Length</i>	<i>Description</i>	<i>Example</i>
responseCode	String	M	7	Response code	2004400
responseMessage	String	M	150	Response description	Successful

<b>Parameter</b>	<b>Data Type</b>	<b>Mandatory</b>	<b>Length</b>	<b>Description</b>	<b>Example</b>
referenceNo	String	C	64	Transaction identifier on service provider system.  Must be filled upon successful transaction	2020102977 7700000000 09
partnerReferenceNo	String	O	64	Transaction identifier on service consumer system	2020102900 0000000000 01
transactionDate	String	O	25	transaction date : ISO 8601 YYYY-MM-DDThh:mm:ss	2020-12- 21T17:55:11 +07:00
additionalInfo	Object	O	N/A	Additional information for custom use that are not provided by SNAP	{"deviceId": "12345679237", "channel": "mobilephone"}

### Contoh Request

```
POST .../v1.0/emoney/otc-cashout HTTP/1.2
Content-type: application/json
Authorization: Bearer
gp9HjjEj813Y9JGoqwOeOPWbnt4CUpvIJbU1mMU4a11MNDZ7Sg5u9a"
```

Authorization-Customer: Bearer  
fa8sjjEj813Y9JGoqwOeOPWbnt4CUpvIJbU1mMU4a11MNDZ7Sg5u9a"  
X-TIMESTAMP: 2020-12-21T17:55:11+07:00  
X-SIGNATURE:  
85be817c55b2c135157c7e89f52499bf0c25ad6eebe04a986e8c862561b19a5  
ORIGIN: www.hostname.com  
X-PARTNER-ID: 82150823919040624621823174737537  
X-EXTERNAL-ID: 41807553358950093184162180797837  
X-IP-ADDRESS: 172.24.281.24  
X-DEVICE-ID: 09864ADCASA  
X-LATITUDE: -6.1617169  
X-LONGITUDE: 106.6643946  
CHANNEL-ID: 95221

```
{
  "partnerReferenceNo": "2020102900000000000001",
  "customerNumber": "6281388370001",
  "otp": "12345678",
  "amount": {
    "value": "10000.00",
    "currency": "IDR"
  },
  "additionalInfo": {
    "deviceId": "12345679237",
    "channel": "mobilephone"
  }
}
```

### Contoh Response

Content-type: application/json  
X-TIMESTAMP: 2020-12-21T17:55:21+07:00

```
{
  "responseCode": "2004400",
  "responseMessage": "Successful",
  "referenceNo": "202010297777000000000009",
  "partnerReferenceNo": "2020102900000000000001",
  "transactionDate": "2020-12-21T17:55:11+07:00",
  "additionalInfo": {
    "deviceId": "12345679237",
    "channel": "mobilephone"
  }
}
```

## b. Transfer Status

### Informasi Umum

<b>Service Code</b>	45
<b>Name</b>	API Transfer to OTC – Transfer Status
<b>Version</b>	1.0
<b>HTTP Method</b>	POST
<b>Path</b>	.../{version}/emoney/otc-status

### Request Body

<i>Parameter</i>	<i>Data Type</i>	<i>Mandatory</i>	<i>Length</i>	<i>Description</i>	<i>Example</i>
originalPartnerReferenceNo	String	M	64	Original transaction identifier on service consumer system	20201029000000000001
originalReferenceNo	String	O	64	Original transaction identifier on service provider system	2020102977770000000009
originalExternalId	String	O	32	Original External-ID on header message	30443786930722726463280097920912
serviceCode	String	M	2	Transaction type indicator. Service code of the transaction that needs to be checked (original transaction).	44

<b>Parameter</b>	<b>Data Type</b>	<b>Mandatory</b>	<b>Length</b>	<b>Description</b>	<b>Example</b>
customerNumber	String	M	32	Customer Account Number	6281388370001
transactionDate	String	O	25	Format transaction date : (ISO 8601) YYYY-MM-DDThh:mm:ss	2020-12-21T14:56:11+07:00
amount	Object	M			
value	String	M	16,2	Net amount of the transaction. If it's IDR then value includes 2 decimal digits. e.g. IDR 10.000,- will be placed with 10000.00	10000.00
currency	String	M	3	Currency (ISO 4217)	IDR
additionalInfo	Object	O	N/A	Additional information for custom use that are not provided by SNAP	{"deviceId": "12345679237", "channel": "mobilephone"}

## Response Body

<b>Parameter</b>	<b>Data Type</b>	<b>Mandatory</b>	<b>Length</b>	<b>Description</b>	<b>Example</b>
responseCode	String	M	7	Response code	2004500
responseMessage	String	M	150	Response description	Successful
originalReferenceNo	String	C	64	Original transaction identifier on service provider system.  Must be filled upon successful original transaction	2020102977 7700000000 09
originalPartnerReferenceNo	String	O	64	Original transaction identifier on service consumer system	2020102900 0000000000 01
originalExternalId	String	O	32	Original External-ID on header message	3044378693 0722726463 2800979209 12
serviceCode	String	M	2	Transaction type indicator. Service code of the transaction that needs to be	44



<b>Parameter</b>	<b>Data Type</b>	<b>Mandatory</b>	<b>Length</b>	<b>Description</b>	<b>Example</b>
				checked (original transaction).	
latestTransactionStatus	String	M	2	<b>00</b> = Success <b>01</b> = Initiated <b>02</b> = Paying <b>03</b> = Pending <b>04</b> = Refunded <b>05</b> = Canceled <b>06</b> = Failed <b>07</b> = Not found	00
transactionStatusDesc	String	O	50	Description of latest transaction status	Success
transactionDate	String	O	25	Format transaction date: (ISO 8601) YYYY-MM-DDThh:mm:ss	2020-12-21T17:55:11+07:00
amount	Object	O			
value	String	M	16,2	Net amount of the transaction. If it's IDR then value includes 2 decimal digits. e.g. IDR 10.000,- will be placed with 10000.00	10000.00

<b>Parameter</b>	<b>Data Type</b>	<b>Mandatory</b>	<b>Length</b>	<b>Description</b>	<b>Example</b>
currency	String	M	3	Currency (ISO 4217)	IDR
additionalInfo	Object	O	N/A	Additional information for custom use that are not provided by SNAP	{ "deviceId": "12345679237", "channel": "mobilephone"}

### Contoh Request

```

POST .../v1.0/emoney/otc-status HTTP/1.2
Content-type: application/json
Authorization: Bearer
gp9HjjEj813Y9JGoqwOeOPWbnt4CUpvIJbU1mMU4a11MNDZ7Sg5u9a"
Authorization-Customer: Bearer
fa8sjjEj813Y9JGoqwOeOPWbnt4CUpvIJbU1mMU4a11MNDZ7Sg5u9a"
X-TIMESTAMP: 2020-12-21T17:55:11+07:00
X-SIGNATURE:
85be817c55b2c135157c7e89f52499bf0c25ad6eebe04a986e8c862561b19a5
ORIGIN: www.hostname.com
X-PARTNER-ID: 82150823919040624621823174737537
X-EXTERNAL-ID: 41807553358950093184162180797837
X-IP-ADDRESS: 172.24.281.24
X-DEVICE-ID: 09864ADCASA
X-LATITUDE: -6.1617169
X-LONGITUDE: 106.6643946
CHANNEL-ID: 95221

```

```

{
  "originalPartnerReferenceNo": "2020102900000000000001",
  "originalReferenceNo": "2020102977770000000009",
  "originalExternalId": "30443786930722726463280097920912",
  "serviceCode": "44",
  "customerNumber": "6281388370001",
  "transactionDate": "2020-12-21T14:56:11+07:00",
  "amount": {
    "value": "10000.00",
    "currency": "IDR"
  },
  "additionalInfo": {
    "deviceId": "12345679237",

```

```
        "channel": "mobilephone"
    }
}
```

### Contoh Response

Content-type: application/json  
X-TIMESTAMP: 2020-12-21T17:55:21+07:00

```
{
  "responseCode": "2004500",
  "responseMessage": "Successful",
  "originalReferenceNo": "20201029777700000000009",
  "originalPartnerReferenceNo": "20201029000000000000001",
  "originalExternalId": "30443786930722726463280097920912",
  "serviceCode": "44",
  "latestTransactionStatus": "00",
  "transactionStatusDesc": "Success",
  "transactionDate": "2020-12-21T17:55:11+07:00",
  "amount": {
    "value": "10000.00",
    "currency": "IDR"
  },
  "additionalInfo": {
    "deviceId": "12345679237",
    "channel": "mobilephone"
  }
}
```

### c. Cancel Payment

#### Informasi Umum

<b>Service Code</b>	46
<b>Name</b>	API Transfer to OTC – Cancel Payment
<b>Version</b>	1.0
<b>HTTP Method</b>	POST
<b>Path</b>	.../{version}/emoney/otc-cancel

#### Request Body

<i>Parameter</i>	<i>Data Type</i>	<i>Mandatory</i>	<i>Length</i>	<i>Description</i>	<i>Example</i>
originalReferenceNo	String	C	64	Original transaction identifier on service provider system to be cancelled.  Must be filled upon successful original transaction	2020102977 7700000000 09
originalPartnerReferenceNo	String	M	64	Original transaction identifier on service consumer system to be cancelled	2020102900 0000000000 01
originalExternalId	String	O	32	Original External-ID on header message	3044378693 0722726463 2800979209 12

<b>Parameter</b>	<b>Data Type</b>	<b>Mandatory</b>	<b>Length</b>	<b>Description</b>	<b>Example</b>
customerNumber	String	M	32	Customer Account Number	6281388370001
reason	String	M	512	Cancellation reason	Cancel reason
additionalInfo	Object	O	N/A	Additional information for custom use that are not provided by SNAP	{"deviceId": "12345679237", "channel": "mobilephone"}

### Response Body

<b>Parameter</b>	<b>Data Type</b>	<b>Mandatory</b>	<b>Length</b>	<b>Description</b>	<b>Example</b>
responseCode	String	M	7	Response code	2004600
responseMessage	String	M	150	Response description	Successful
originalReferenceNo	String	M	64	Original transaction identifier on service provider system to be cancelled	2020102977770000000009
originalPartnerReferenceNo	String	O	64	Original transaction identifier on service consumer	20201029000000000001

<b>Parameter</b>	<b>Data Type</b>	<b>Mandatory</b>	<b>Length</b>	<b>Description</b>	<b>Example</b>
				system to be cancelled	
originalExternalId	String	O	32	Original External-ID on header message	3044378693 0722726463 2800979209 12
cancelTime	String	C	25	Cancel time  Format cancel time: (ISO 8601) YYYY-MM-DDThh:mm:ss  Must be filled upon successful cancel transaction	2020-12-21T17:07:25+07:00
transactionDate	String	O	25	Format transaction date : (ISO 8601) YYYY-MM-DDThh:mm:ss	2020-12-21T17:07:25+07:00
additionalInfo	Object	O	N/A	Additional information for custom use that are not provided by SNAP	{"deviceId": "12345679237", "channel": "mobilephone"}

### Contoh Request

```
POST .../v1.0/otc/emoney/otc-cancel HTTP/1.2
Content-type: application/json
```

Authorization: Bearer  
gp9HjjEj813Y9JGoqwOeOPWbnt4CUpvIJbU1mMU4a11MNDZ7Sg5u9a"  
Authorization-Customer: Bearer  
fa8sjjEj813Y9JGoqwOeOPWbnt4CUpvIJbU1mMU4a11MNDZ7Sg5u9a"  
X-TIMESTAMP: 2020-12-21T17:55:11+07:00  
X-SIGNATURE:  
85be817c55b2c135157c7e89f52499bf0c25ad6eeeb04a986e8c862561b19a5  
ORIGIN: www.hostname.com  
X-PARTNER-ID: 82150823919040624621823174737537  
X-EXTERNAL-ID: 41807553358950093184162180797837  
X-IP-ADDRESS: 172.24.281.24  
X-DEVICE-ID: 09864ADCASA  
X-LATITUDE: -6.1617169  
X-LONGITUDE: 106.6643946  
CHANNEL-ID: 95221

```
{
  "originalReferenceNo": "2020102977770000000009",
  "originalPartnerReferenceNo": "2020102900000000000001",
  "originalExternalId": "30443786930722726463280097920912",
  "customerNumber": "6281388370001",
  "reason": "timeout",
  "additionalInfo": {
    "deviceId": "12345679237",
    "channel": "mobilephone"
  }
}
```

### Contoh Response

Content-type: application/json  
X-TIMESTAMP: 2020-12-21T17:55:21+07:00

```
{
  "responseCode": "2004600",
  "responseMessage": "Successful",
  "originalReferenceNo": "2020102977770000000009",
  "originalPartnerReferenceNo": "2020102900000000000001",
  "originalExternalId": "30443786930722726463280097920912",
  "cancelTime": "2020-12-21T17:07:25+07:00",
  "transactionDate": "2020-12-21T17:55:11+07:00",
  "additionalInfo": {
    "deviceId": "12345679237",
    "channel": "mobilephone"
  }
}
```

### 4.3.5. API QR MPM

### Sequence Diagram

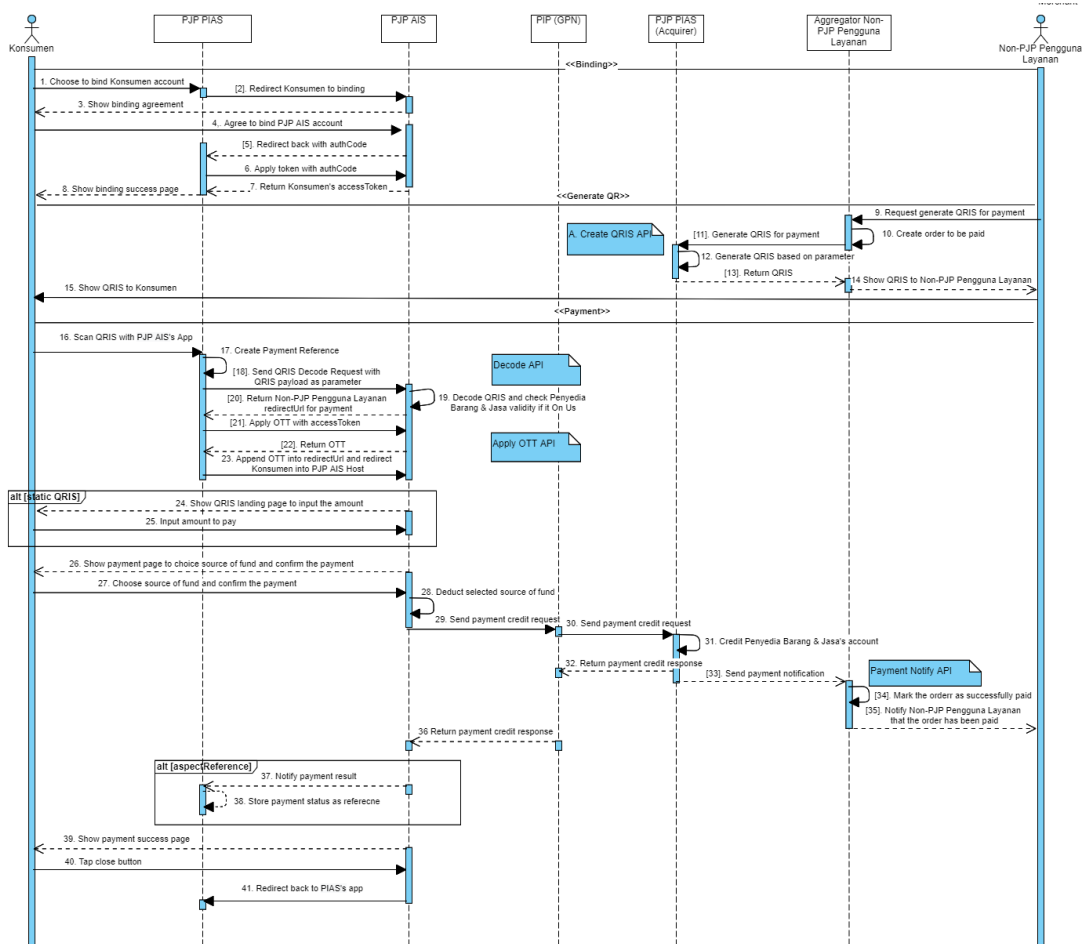

Sequence Diagram API QR MPM - Payment Redirect



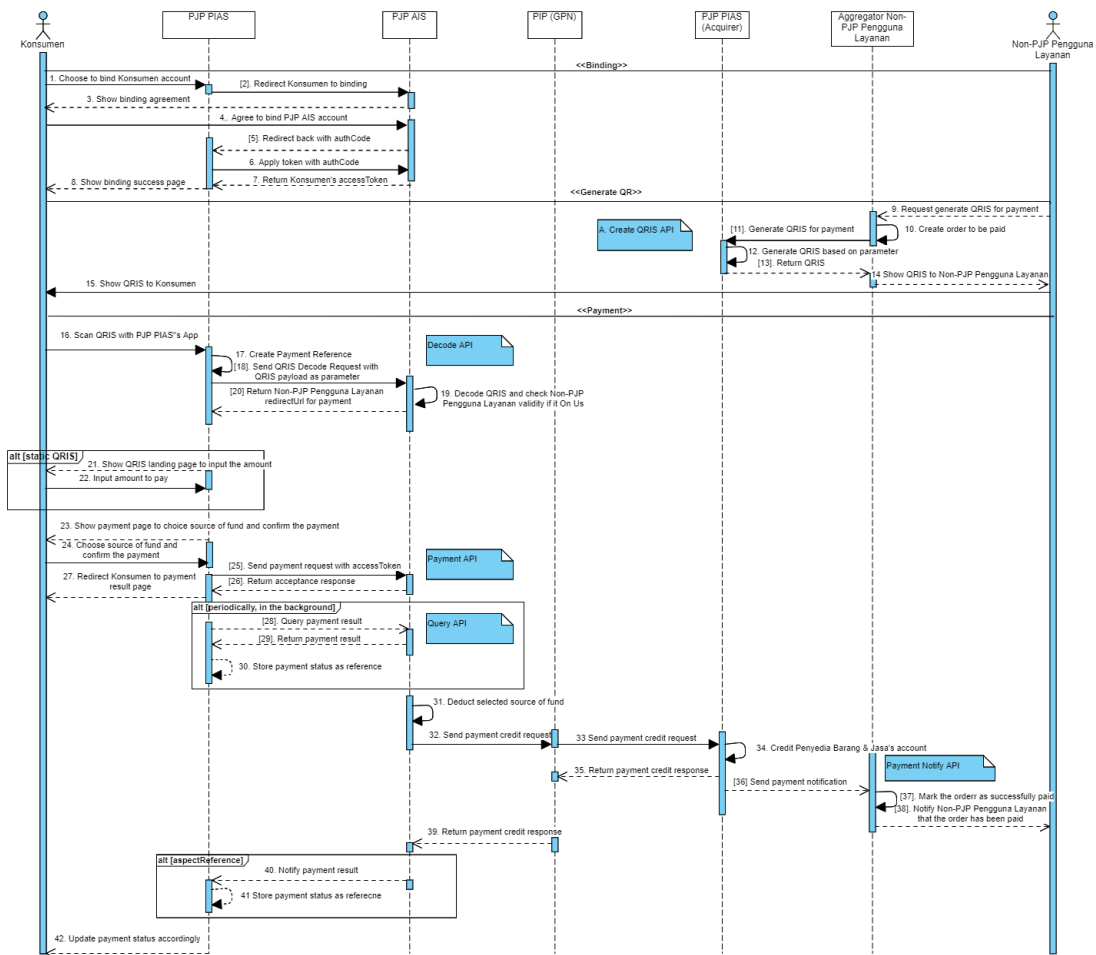

Sequence Diagram API QR MPM – Host to Host

**a. Generate QR**  
**Informasi Umum**

<b>Service Code</b>	47
<b>Name</b>	API Generate QR MPM
<b>Version</b>	1.0
<b>HTTP Method</b>	POST
<b>Path</b>	.../{version}/qr/qr-mpm-generate

## Request Body

<b>Parameter</b>	<b>Data Type</b>	<b>Mandatory</b>	<b>Length</b>	<b>Description</b>	<b>Example</b>
partnerReferenceNo	String	O	64	Transaction identifier on service consumer system	202010290000000000001
amount	Object	O			
value	String	M	16,2	Net amount of the transaction. If it's IDR then value includes 2 decimal digits. e.g. IDR 10.000,- will be placed with 10000.00 with 2 decimal	12345678.00
currency	String	M	3	Currency (ISO 4217)	IDR
feeAmount	Object	O			
value	String	M	16,2	Transaction fee	12345678.00
currency	String	M	3	Currency (ISO 4217)	IDR
merchantId	String	O	64	Merchant identifier that is unique per each merchant	00007100010926
subMerchantId	String	O	32	Sub merchant ID	310928924949487
storeId	String	O	64	Unique shop id in merchant side.	abcd

<b>Parameter</b>	<b>Data Type</b>	<b>Mandatory</b>	<b>Length</b>	<b>Description</b>	<b>Example</b>
terminalId	String	O	16	Terminal Identification	213141251124
validityPeriod	String	O	25	The time when the QRIS valid  Format validity period: (ISO 8601) YYYY-MM-DDThh:mm:ss	2009-07-03T12:08:56+07:00
additionalInfo	Object	O	N/A	Additional information for custom use that are not provided by SNAP	{"deviceId": "12345679237", "channel": "mobilephone"}

### Response Body

<b>Parameter</b>	<b>Data Type</b>	<b>Mandatory</b>	<b>Length</b>	<b>Description</b>	<b>Example</b>
responseCode	String	M	7	Response code	2004700
responseMessage	String	M	150	Response description	Successful
referenceNo	String	O	64	Transaction identifier on service provider system.	2020102977770000000009
partnerReferenceNo	String	O	64	Transaction identifier on service consumer system	202010290000000000001

<b>Parameter</b>	<b>Data Type</b>	<b>Mandatory</b>	<b>Length</b>	<b>Description</b>	<b>Example</b>
qrContent	String	C	512	QR String MPM. Must be filled if both qrUrl and qrImage are null	xxxxxxxxxxxxx x
qrUrl	String	O	256	QR URL for download QR Image	<a href="https://qrurl?img=12345">https://qrurl?img=12345</a>
qrImage	String	O	N/A	base64 from image QRIS. Max length is unlimited.	TWFuIGlzlIGR pc3Rpbmd1a XNoZWQsIG5 vdCBvbmx5I GJ5IGhpcyB yZWZzb24sI GJ1dCAuLi4=
redirectUrl	String	O	512	Redirect URL to go to PJSP page to process the payment.	https://test. psjp.id/redire ct/qrisk? x=238490324 092
merchantName	String	O	25	Reference number	Baso Malang
storeId	String	O	64	Unique shop id in merchant side.	abcd
terminalId	String	O	16	Terminal Identification	2131412511 24
additionalInfo	Object	O	N/A	Additional information for custom use that	{"deviceId": "12345679237",

<b>Parameter</b>	<b>Data Type</b>	<b>Mandatory</b>	<b>Length</b>	<b>Description</b>	<b>Example</b>
				are not provided by SNAP	"channel": "mobilephone"}

### Contoh Request

```
POST .../v1.0/qr/qr-mpm-generate HTTP/1.2
Content-type: application/json
Authorization: Bearer
gp9HjjEj813Y9JGoqwOeOPWbnt4CUpvIJbU1mMU4a11MNDZ7Sg5u9a"
Authorization-Customer: Bearer
fa8sjjEj813Y9JGoqwOeOPWbnt4CUpvIJbU1mMU4a11MNDZ7Sg5u9a"
X-TIMESTAMP: 2020-01-15T17:01:11+07:00
X-SIGNATURE:
85be817c55b2c135157c7e89f52499bf0c25ad6eeeb04a986e8c862561b19a5
ORIGIN: www.hostname.com
X-PARTNER-ID: 82150823919040624621823174737537
X-EXTERNAL-ID: 41807553358950093184162180797837
X-IP-ADDRESS: 172.24.281.24
X-DEVICE-ID: 09864ADCASA
X-LATITUDE: -6.108841
X-LONGITUDE: 106.7782137
CHANNEL-ID: 95221
```

```
{
  "partnerReferenceNo": "202010290000000000000001",
  "amount": {
    "value": "12345678.00",
    "currency": "IDR"
  },
  "feeAmount": {
    "value": "12345678.00",
    "currency": "IDR"
  },
  "merchantId": "00007100010926",
  "subMerchantId": "310928924949487",
  "storeId": "abcd",
  "terminalId": "213141251124",
  "validityPeriod": "2009-07-03T12:08:56+07:00",
  "additionalInfo": {
    "deviceId": "12345679237",
    "channel": "mobilephone"
  }
}
```

## Contoh Response

Content-type: application/json  
X-TIMESTAMP: 2020-01-15T17:01:18+07:00

```
{
  "responseCode": "2004700",
  "responseMessage": "Successful",
  "referenceNo": "2020102977770000000009",
  "partnerReferenceNo": "2020102900000000000001",
  "qrContent": "xxxxxxxxxxxxxxxxxx",
  "qrUrl": https://qrurl?img=12345,
  "qrImage": "TWFuIGlzIGRpc3Rpbmd1aXNoZWQsIG5vdCBvbmx5IGJ5IGhpcy  
ByZWZzb24sIGJldCAuLi4=",
  "redirectUrl": "https://test.psjp.id/redirect/qr?  
x=238490324092",
  "merchantName": "Baso Malang",
  "storeId": "abcd",
  "terminalId": "213141251124",
  "additionalInfo": {
    "deviceId": "12345679237",
    "channel": "mobilephone"
  }
}
```

## b. Decode QR

### Informasi Umum

<b>Service Code</b>	48
<b>Name</b>	API Decode QR MPM
<b>Version</b>	1.0
<b>HTTP Method</b>	POST
<b>Path</b>	.../{version}/qr/qr-mpm-decode

### Request Body

<i>Parameter</i>	<i>Data Type</i>	<i>Mandatory</i>	<i>Length</i>	<i>Description</i>	<i>Example</i>
partnerReferenceNo	String	O	64	Transaction identifier on service consumer system	2020102900 0000000000 01
qrContent	String	M	512	QR String MPM	00020101....
amount	Object	O			
value	String	M	16,2	Net amount of the transaction. If it's IDR then value includes 2 decimal digits. e.g. IDR 10.000,- will be placed with 10000.00	10000.00
currency	String	M	3	Currency (ISO 4217)	IDR
merchantId	String	O	64	Merchant identifier that is	2348918230 3312

<b>Parameter</b>	<b>Data Type</b>	<b>Mandatory</b>	<b>Length</b>	<b>Description</b>	<b>Example</b>
				unique per each merchant	
subMerchantId	String	O	32	Sub merchant ID	23489182303312
scanTime	String	M	25	The time when the QRIS scanned by the User  Format scan time: (ISO 8601) YYYY-MM-DDThh:mm:ss	2020-12-23T08:27:11+07:00
additionalInfo	Object	O	N/A	Additional information for custom use that are not provided by SNAP	{"deviceId": "12345679237", "channel": "mobilephone"}

### Response Body

<b>Parameter</b>	<b>Data Type</b>	<b>Mandatory</b>	<b>Length</b>	<b>Description</b>	<b>Example</b>
responseCode	String	M	7	Response code	2004800
responseMessage	String	M	150	Response description	Successful
referenceNo	String	C	64	Transaction identifier on service provider system.	2020102977770000000009



<b>Parameter</b>	<b>Data Type</b>	<b>Mandatory</b>	<b>Length</b>	<b>Description</b>	<b>Example</b>
				Must be filled upon successful transaction	
partnerReferenceNo	String	O	64	Transaction identifier on service consumer system	2020102900 0000000000 01
redirectUrl	String	C	512	Redirect URL to go to PJSP page to process the payment.  Mandatory if using redirect mode for transaction	https://test.psjp.id/redirect/qris?x=238490324092
merchantName	String	C	25	Merchant Name.  Mandatory if using Host to Host mode for transaction	Baso Malang
merchantCategory	String	C	32	Merchant category.  Mandatory if using Host to Host mode for transaction	Food & Beverage
merchantLocation	String	C	25	Merchant location.  Mandatory if using Host to Host mode for transaction	Jakarta
merchantInfos	Array	M		Merchant account	

<b>Parameter</b>	<b>Data Type</b>	<b>Mandatory</b>	<b>Length</b>	<b>Description</b>	<b>Example</b>
	<i>of Objects</i>			information	
merchantPAN	<i>Numeric</i>	M	19	Merchant PAN Mandatory if using Host to Host mode for transaction	9360001410 000000009
acquirerName	<i>String</i>	M	50	Acquirer Name Mandatory if using Host to Host mode for transaction	BCA
transactionAmount	<i>Object</i>	O			
value	<i>String</i>	M	16,2	Net amount of the transaction. If it's IDR then value includes 2 decimal digits. e.g. IDR 10.000,- will be placed with 10000.00	12345678.00
currency	<i>String</i>	M	3	Currency (ISO 4217)	IDR
feeAmount	<i>Object</i>	O			
value	<i>String</i>	M	16,2	Net amount of the transaction.	12345678.00

<b>Parameter</b>	<b>Data Type</b>	<b>Mandatory</b>	<b>Length</b>	<b>Description</b>	<b>Example</b>
				If it's IDR then value includes 2 decimal digits. e.g. IDR 10.000,- will be placed with 10000.00	
currency	String	M	3	Currency (ISO 4217)	IDR
additionalInfo	Object	O	N/A	Additional information for custom use that are not provided by SNAP	{ "deviceId": "12345679237", "channel": "mobilephone"}

### Contoh Request

```

POST .../v1.0/qr/qr-mpm-decode HTTP/1.2
Content-type: application/json
Authorization: Bearer
gp9HjjEj813Y9JGoqwOeOPWbnt4CUpvIJbU1mMU4a11MNDZ7Sg5u9a"
Authorization-Customer: Bearer
fa8sjjEj813Y9JGoqwOeOPWbnt4CUpvIJbU1mMU4a11MNDZ7Sg5u9a"
X-TIMESTAMP: 2020-12-23T08:27:11+07:00
X-SIGNATURE:
85be817c55b2c135157c7e89f52499bf0c25ad6eebe04a986e8c862561b19a5
ORIGIN: www.hostname.com
X-PARTNER-ID: 82150823919040624621823174737537
X-EXTERNAL-ID: 41807553358950093184162180797837
X-IP-ADDRESS: 172.24.281.24
X-DEVICE-ID: 09864ADCASA
X-LATITUDE: -6.108841
X-LONGITUDE: 106.7782137
CHANNEL-ID: 95221

{
  "partnerReferenceNo": "202010290000000000000001",
  "qrContent": "00020101....",
  "amount": {

```

```

        "value": "10000.00",
        "currency": "IDR"
    },
    "merchantId": "23489182303312",
    "subMerchantId": "23489182303312",
    "scanTime": "2020-12-23T08:27:11+07:00",
    "additionalInfo": {
        "deviceId": "12345679237",
        "channel": "mobilephone"
    }
}

```

## Contoh Response

Content-type: application/json  
X-TIMESTAMP: 2020-12-23T08:27:18+07:00

```

{
    "responseCode": "2004800",
    "responseMessage": "Successful",
    "referenceNo": "2020102977770000000009",
    "partnerReferenceNo": "2020102900000000000001",
    "redirectUrl": "https://test.psjp.id/redirect/gris?x=238490324092",
    "merchantName": "Baso Malang",
    "merchantCategory": "Food & Beverage",
    "merchantLocation": "Jakarta",
    "merchantInfos": [
        {
            "merchantPAN": "9360001410000000009",
            "acquirerName": "BCA"
        },
        {
            "merchantPAN": "9360001310000000001",
            "acquirerName": "PERMATA"
        }
    ],
    "transactionAmount": {
        "value": "12345678.00",
        "currency": "IDR"
    },
    "feeAmount": {
        "value": "12345678.00",
        "currency": "IDR"
    },
    "additionalInfo": {
        "deviceId": "12345679237",

```

```
    "channel": "mobilephone"  
  }  
}
```

### c. Payment Redirect – Apply OTT

#### Informasi Umum

<b>Service Code</b>	49
<b>Name</b>	API Payment Redirect
<b>Version</b>	1.0
<b>HTTP Method</b>	POST
<b>Path</b>	.../{version}/qr/apply-ott

#### Request Body

<b>Parameter</b>	<b>Data Type</b>	<b>Mandatory</b>	<b>Length</b>	<b>Description</b>	<b>Example</b>
userResources	Array of Strings	M	64	One time token	["OTT"]
additionalInfo	Object	O	N/A	Additional information for custom use that are not provided by SNAP	{ "deviceId": "12345679237", "channel": "mobilephone"}

#### Response Body

<b>Parameter</b>	<b>Data Type</b>	<b>Mandatory</b>	<b>Length</b>	<b>Description</b>	<b>Example</b>
responseCode	String	M	7	Response code	2004900
responseMessage	String	M	150	Response description	Successful
userResources	Array of Objects	M			
resourceType	String	M	32	Resource retrieved.	OTT
value	String	M	64	Value of	jadoijasod98

<b>Parameter</b>	<b>Data Type</b>	<b>Mandatory</b>	<b>Length</b>	<b>Description</b>	<b>Example</b>
				resource from resourceType parameter	7984712094 7201ifh0afhq 08hd1038
additionalInfo	Object	O	N/A	Additional information for custom use that are not provided by SNAP	{"deviceId": "12345679237", "channel": "mobilephone"}

### Contoh Request

```

POST .../v1.0/qr/apply-ott HTTP/1.2
Content-type: application/json
Authorization: Bearer
gp9HjjEj813Y9JGoqwOeOPWbnt4CUpvIJbU1mMU4a11MNDZ7Sg5u9a"
Authorization-Customer: Bearer
fa8sjjEj813Y9JGoqwOeOPWbnt4CUpvIJbU1mMU4a11MNDZ7Sg5u9a"
X-TIMESTAMP: 2020-12-23T08:31:11+07:00
X-SIGNATURE:
85be817c55b2c135157c7e89f52499bf0c25ad6eebe04a986e8c862561b19a5
ORIGIN: www.hostname.com
X-PARTNER-ID: 82150823919040624621823174737537
X-EXTERNAL-ID: 41807553358950093184162180797837
X-IP-ADDRESS: 172.24.281.24
X-DEVICE-ID: 09864ADCASA
X-LATITUDE: -6.108841
X-LONGITUDE: 106.7782137
CHANNEL-ID: 95221

{
  "userResources":["OTT"],
  "additionalInfo":{
    "deviceId":"12345679237",
    "channel":"mobilephone"
  }
}

```

### Contoh Response

```

Content-type: application/json
X-TIMESTAMP: 2020-12-23T08:31:18+07:00

```

```
{
  "responseCode": "2004900",
  "responseMessage": "Successful",
  "userResources": [{
    "resourceType": "OTT",
    "value": "jadoijasod9879847120947201ifh0afhq08hd1038"
  }]
  "additionalInfo": {
    "deviceId": "12345679237",
    "channel": "mobilephone"
  }
}
```



#### d. Payment – Host to Host

##### Informasi Umum

<b>Service Code</b>	50
<b>Name</b>	API Payment – Host to Host
<b>Version</b>	1.0
<b>HTTP Method</b>	POST
<b>Path</b>	.../{version}/qr/qr-mpm-payment

##### Request Body

<i>Parameter</i>	<i>Data Type</i>	<i>Mandatory</i>	<i>Length</i>	<i>Description</i>	<i>Example</i>
partnerReferenceNo	String	M	64	Transaction identifier on service consumer system	2020102900 0000000000 01
merchantId	String	O	64	Merchant identifier that is unique per each merchant	0000710001 0926
subMerchantId	String	O	32	Sub merchant ID	3109289249 49487
amount	Object	O			
value	String	M	16,2	Net amount of the transaction. If it's IDR then value includes 2 decimal digits. e.g. IDR 10.000,- will be	12345678.00

<b>Parameter</b>	<b>Data Type</b>	<b>Mandatory</b>	<b>Length</b>	<b>Description</b>	<b>Example</b>
				placed with 10000.00	
currency	String	M	3	Currency (ISO 4217)	IDR
feeAmount	Object	O			
value	String	M	16,2	Net amount of the transaction. If it's IDR then value includes 2 decimal digits. e.g. IDR 10.000,- will be placed with 10000.00	12345678.00
currency	String	M	3	Currency (ISO 4217)	IDR
otp	String	O	8	One-time password	12345678
verificationId	String	O	32	To accomodate verification OTP transaction	3109289249 49487
additionalInfo	Object	O	N/A	Additional information for custom use that are not provided by SNAP	{"deviceId": "12345679237", "channel": "mobilephone"}

## Response Body

<b>Parameter</b>	<b>Data Type</b>	<b>Mandatory</b>	<b>Length</b>	<b>Description</b>	<b>Example</b>
responseCode	String	M	7	Response code	2005000
responseMessage	String	M	150	Response description	Successful
referenceNo	String	C	64	Transaction identifier on service provider system.  Must be filled upon successful transaction	2020102977 7700000000 09
partnerReferenceNo	String	O	64	Transaction identifier on service consumer system	2020102900 0000000000 01
transactionDate	String	O	25	Format transaction date : (ISO 8601) YYYY-MM-DDThh:mm:ss	2020-12- 23T08:37:11 +07:00
amount	Object	O			
value	String	M	16,2	Net amount of the transaction. If it's IDR then value includes 2 decimal digits. e.g. IDR 10.000,- will be	12345678.00

<b>Parameter</b>	<b>Data Type</b>	<b>Mandatory</b>	<b>Length</b>	<b>Description</b>	<b>Example</b>
				placed with 10000.00	
currency	String	M	3	Currency (ISO 4217)	IDR
feeAmount	Object	O			
value	String	M	16,2	Net amount of the transaction. If it's IDR then value includes 2 decimal digits. e.g. IDR 10.000,- will be placed with 10000.00	12345678.00
currency	String	M	3	Currency (ISO 4217)	IDR
verificationId	String	O	64	Verification identifier, if verification is required	8921840jfas0 dfjasd09dj11 29jd0921d
additionalInfo	Object	O	N/A	Additional information for custom use that are not provided by SNAP	{"deviceId": "12345679237", "channel": "mobilephone"}

## Contoh Request

```
POST .../v1.0/qr/qr-mpm-payment HTTP/1.2
Content-type: application/json
Authorization: Bearer
gp9HjjEj813Y9JGoqwOeOPWbnt4CUpvIJbU1mMU4a11MNDZ7Sg5u9a"
Authorization-Customer: Bearer
fa8sjjEj813Y9JGoqwOeOPWbnt4CUpvIJbU1mMU4a11MNDZ7Sg5u9a"
X-TIMESTAMP: 2020-12-23T08:37:11+07:00
X-SIGNATURE:
85be817c55b2c135157c7e89f52499bf0c25ad6eeeb04a986e8c862561b19a5
ORIGIN: www.hostname.com
X-PARTNER-ID: 82150823919040624621823174737537
X-EXTERNAL-ID: 41807553358950093184162180797837
X-IP-ADDRESS: 172.24.281.24
X-DEVICE-ID: 09864ADCASA
X-LATITUDE: -6.108841
X-LONGITUDE: 106.7782137
CHANNEL-ID: 95221
```

```
{
  "partnerReferenceNo": "2020102900000000000001",
  "merchantId": "00007100010926",
  "subMerchantId": "310928924949487",
  "amount": {
    "value": "12345678.00",
    "currency": "IDR"
  },
  "feeAmount": {
    "value": "12345678.00",
    "currency": "IDR"
  },
  "otp": "12345678",
  "verificationId": "310928924949487",
  "additionalInfo": {
    "deviceId": "12345679237",
    "channel": "mobilephone"
  }
}
```

## Contoh Response

```
Content-type: application/json
X-TIMESTAMP: 2020-12-23T08:37:21+07:00
```

```
{
  "responseCode": "2005000",
  "responseMessage": "Successful",
  "referenceNo": "2020102977770000000009",
  "partnerReferenceNo": "2020102900000000000001",
```

```
"transactionDate":"2020-12-23T08:37:11+07:00",
"amount":{
  "value":"12345678.00",
  "currency":"IDR"
},
"feeAmount":{
  "value":"12345678.00",
  "currency":"IDR"
},
"verificationId":"8921840jfas0dfjasd09dj1129jd0921d",
"additionalInfo":{
  "deviceId":"12345679237",
  "channel":"mobilephone"
}
}
```

## e. Query Payment

### Informasi Umum

<b>Service Code</b>	51
<b>Name</b>	API Query Payment
<b>Version</b>	1.0
<b>HTTP Method</b>	POST
<b>Path</b>	.../{version}/qr/qr-mpm-query

### Request Body

<i>Parameter</i>	<i>Data Type</i>	<i>Mandatory</i>	<i>Length</i>	<i>Description</i>	<i>Example</i>
originalReferenceNo	String	O	64	Original transaction identifier on service provider system	2020102977 7700000000 09
originalPartnerReferenceNo	String	O	64	Original transaction identifier on service consumer system	2020102900 0000000000 01
originalExternalId	String	O	32	Original External-ID on header message	3044378693 0722726463 2800979209 12
serviceCode	String	M	2	Transaction type indicator. Service code of the transaction that needs to be checked (original transaction).	47/49/50

<b>Parameter</b>	<b>Data Type</b>	<b>Mandatory</b>	<b>Length</b>	<b>Description</b>	<b>Example</b>
merchantId	String	O	64	Merchant identifier that is unique per each merchant	00007100010926
subMerchantId	String	O	32	Sub merchant Id	310928924949487
externalStoreId	String	O	64	External Store Id	124928924949487
additionalInfo	Object	O	N/A	Additional information for custom use that are not provided by SNAP	{"deviceId": "12345679237", "channel": "mobilephone"}

### Response Body

<b>Parameter</b>	<b>Data Type</b>	<b>Mandatory</b>	<b>Length</b>	<b>Description</b>	<b>Example</b>
responseCode	String	M	7	Response code	2005100
responseMessage	String	M	150	Response description	Successful
originalReferenceNo	String	C	64	Original transaction identifier on service provider system. Must be filled upon successful original transaction	2020102977770000000009



<b>Parameter</b>	<b>Data Type</b>	<b>Mandatory</b>	<b>Length</b>	<b>Description</b>	<b>Example</b>
originalPartnerReferenceNo	String	O	64	Original transaction identifier on service consumer system	2020102900 0000000000 01
originalExternalId	String	O	32	Original External-ID on header message	3044378693 0722726463 2800979209 12
serviceCode	String	M	2	Transaction type indicator. Service code of the transaction that needs to be checked (original transaction).	47/49/50
latestTransactionStatus	String	M	2	<b>00</b> = Success <b>01</b> = Initiated <b>02</b> = Paying <b>03</b> = Pending <b>04</b> = Refunded <b>05</b> = Canceled <b>06</b> = Failed <b>07</b> = Not found	00
transactionStatusDesc	String	O	50	Description status transaction	Success
paidTime	String	C	25	Transaction date : ISO 8601	2020-10- 20T17:56:57

<b>Parameter</b>	<b>Data Type</b>	<b>Mandatory</b>	<b>Length</b>	<b>Description</b>	<b>Example</b>
				YYYY-MM-DDThh:mm:ss  Must be filled upon successful original transaction.	+07:00
amount	<i>Object</i>	O			
value	<i>String</i>	M	16,2	Net amount of the transaction. If it's IDR then value includes 2 decimal digits. e.g. IDR 10.000,- will be placed with 10000.00	12345678.00
currency	<i>String</i>	M	3	Currency (ISO 4217)	IDR
feeAmount	<i>Object</i>	O			
value	<i>String</i>	M	16,2	Net amount of the transaction. If it's IDR then value includes 2 decimal digits.	12345678.00

<b>Parameter</b>	<b>Data Type</b>	<b>Mandatory</b>	<b>Length</b>	<b>Description</b>	<b>Example</b>
				e.g. IDR 10.000,- will be placed	
currency	String	M	3	Currency (ISO 4217)	IDR
terminalId	String	O	16	Terminal Identification	2131412511 24
additionalInfo	Object	O	N/A	Additional information for custom use that are not provided by SNAP	{"deviceId": "12345679237", "channel": "mobilephone"}

### Contoh Request

```

POST .../v1.0/qr/qr-mpm-query HTTP/1.2
Content-type: application/json
Authorization: Bearer
gp9HjjEj813Y9JGoqwOeOPWbnt4CUpvIJbU1mMU4a11MNDZ7Sg5u9a"
Authorization-Customer: Bearer
fa8sJJjEj813Y9JGoqwOeOPWbnt4CUpvIJbU1mMU4a11MNDZ7Sg5u9a"
X-TIMESTAMP: 2020-12-23T08:43:11+07:00
X-SIGNATURE:
85be817c55b2c135157c7e89f52499bf0c25ad6eebe04a986e8c862561b19a5
ORIGIN: www.hostname.com
X-PARTNER-ID: 82150823919040624621823174737537
X-EXTERNAL-ID: 41807553358950093184162180797837
X-IP-ADDRESS: 172.24.281.24
X-DEVICE-ID: 09864ADCASA
X-LATITUDE: -6.108841
X-LONGITUDE: 106.7782137
CHANNEL-ID: 95221
{
  "originalReferenceNo": "2020102977770000000009",
  "originalPartnerReferenceNo": "2020102900000000000001",
  "originalExternalId": "30443786930722726463097920912",
  "serviceCode": "47",
  "merchantId": "00007100010926",
  "subMerchantId": "310928924949487",

```

```
    "externalStoreId": "124928924949487",
    "additionalInfo": {
      "deviceId": "12345679237",
      "channel": "mobilephone"
    }
  }
}
```

### Contoh Response

Content-type: application/json  
X-TIMESTAMP: 2020-12-23T08:43:16+07:00

```
{
  "responseCode": "2005100",
  "responseMessage": "Successful",
  "originalReferenceNo": "20201029777700000000009",
  "originalPartnerReferenceNo": "20201029000000000000001",
  "originalExternalId": "30443786930722726463097920912",
  "serviceCode": "47",
  "latestTransactionStatus": "00",
  "transactionStatusDesc": "success",
  "paidTime": "2020-10-20T17:56:57+07:00",
  "amount": {
    "value": "12345678.00",
    "currency": "IDR"
  },
  "feeAmount": {
    "value": "12345678.00",
    "currency": "IDR"
  },
  "terminalId": "213141251124",
  "additionalInfo": {
    "deviceId": "12345679237",
    "channel": "mobilephone"
  }
}
```

## f. Payment Notify

### Informasi Umum

<b>Service Code</b>	52
<b>Name</b>	API Payment Notification
<b>Version</b>	1.0
<b>HTTP Method</b>	POST
<b>Path</b>	.../{version}/qr/qr-mpm-notify

### Request Body

<i>Parameter</i>	<i>Data Type</i>	<i>Mandatory</i>	<i>Length</i>	<i>Description</i>	<i>Example</i>
originalReferenceNo	String	M	64	Transaction identifier on service provider system	2020102977 7700000000 09
originalPartnerReferenceNo	String	O	64	Transaction identifier on service consumer system	2020102900 0000000000 01
latestTransactionStatus	String	M	2	<b>00</b> = Success <b>01</b> = Initiated <b>02</b> = Paying <b>03</b> = Pending <b>04</b> = Refunded <b>05</b> = Canceled <b>06</b> = Failed <b>07</b> = Not found	00
transactionStatusDesc	String	O	50	Description status transaction	Success

<b>Parameter</b>	<b>Data Type</b>	<b>Mandatory</b>	<b>Length</b>	<b>Description</b>	<b>Example</b>
customerNumber	String	O	64	Customer Account Number	6281388370001
accountType	String	O	25	Account type	tabungan
destinationNumber	String	O	25	Destination account number	8377388292
destinationAccountName	String	O	25	Destination account name	John doe
amount	Object	O			
value	String	M	16,2	Net amount of the transaction. If it's IDR then value includes 2 decimal digits. e.g. IDR 10.000,- will be placed with 10000.00	12345678.00
currency	String	M	3	Currency (ISO 4217)	IDR
sessionId	String	O	25	Session id	0UYEB77329002HY
bankCode	String	O	8	Bank code	002
externalStoreId	String	O	64	External Store Id	124928924949487
additionalInfo	Object	O	N/A	Additional information for custom use that	{"deviceId": "12345679237", "channel": "mobilephone"}

<b>Parameter</b>	<b>Data Type</b>	<b>Mandatory</b>	<b>Length</b>	<b>Description</b>	<b>Example</b>
				are not provided by SNAP	

### Response Body

<b>Parameter</b>	<b>Data Type</b>	<b>Mandatory</b>	<b>Length</b>	<b>Description</b>	<b>Example</b>
responseCode	String	M	7	Response code	2005200
responseMessage	String	M	150	Response description	Successful
additionalInfo	Object	O	N/A	Additional information for custom use that are not provided by SNAP	{"deviceId": "12345679237", "channel": "mobilephone"}

### Contoh Request

```

POST .../v1.0/qr/qr-mpm-notify HTTP/1.2
Content-type: application/json
Authorization: Bearer
gp9HjjEj813Y9JGoqwOeOPWbnt4CUpvIJbU1mMU4a11MNDZ7Sg5u9a"
Authorization-Customer: Bearer
fa8sjjEj813Y9JGoqwOeOPWbnt4CUpvIJbU1mMU4a11MNDZ7Sg5u9a"
X-TIMESTAMP: 2020-12-23T08:46:11+07:00
X-SIGNATURE:
85be817c55b2c135157c7e89f52499bf0c25ad6eebe04a986e8c862561b19a5
ORIGIN: www.hostname.com
X-PARTNER-ID: 82150823919040624621823174737537
X-EXTERNAL-ID: 41807553358950093184162180797837
X-IP-ADDRESS: 172.24.281.24
X-DEVICE-ID: 09864ADCASA
X-LATITUDE: -6.108841
X-LONGITUDE: 106.7782137
CHANNEL-ID: 95221

```

```

{
  "originalReferenceNo": "2020102977770000000009",

```

```
"originalPartnerReferenceNo":"202010290000000000000001",
"latestTransactionStatus":"00",
"transactionStatusDesc":"Success",
"customerNumber":"6281388370001",
"accountType":"tabungan",
"destinationNumber":"8377388292",
"destinationAccountName":"John Doe",
"amount":{
  "value":"12345678.00",
  "currency":"IDR"
},
"sessionId":"0UYEB77329002HY",
"bankCode":"002",
"externalStoreId":"124928924949487",
"additionalInfo":{
  "deviceId":"12345679237",
  "channel":"mobilephone"
}
}
```

### Contoh Response

```
Content-type: application/json
X-TIMESTAMP: 2020-12-23T08:46:16+07:00
```

```
{
  "responseCode":"2005200",
  "responseMessage":"Successful",
  "additionalInfo":{
    "deviceId":"12345679237",
    "channel":"mobilephone"
  }
}
```



## g. Cancel Payment

### Informasi Umum

<b>Service Code</b>	77
<b>Name</b>	API Cancel Payment
<b>Version</b>	1.0
<b>HTTP Method</b>	POST
<b>Path</b>	.../{version}/qr/qr-mpm-cancel

### Request Body

<b>Parameter</b>	<b>Data Type</b>	<b>Mandatory</b>	<b>Length</b>	<b>Description</b>	<b>Example</b>
originalPartnerReferenceNo	String	O	64	Original transaction identifier on service consumer system	2020102900 0000000000 01
originalReferenceNo	String	O	64	Original transaction identifier on service provider system	2020102977 7700000000 09
originalExternalId	String	O	32	Original External-ID on header message	3044378693 0722726463 2800979209 12
merchantId	String	M	64	Merchant identifier that is unique per each merchant	0000710001 0926
subMerchantId	String	O	32	Sub merchant ID	3109289249 49487
externalStoreId	String	O	64	External Store ID	1249289249 49487

<b>Parameter</b>	<b>Data Type</b>	<b>Mandatory</b>	<b>Length</b>	<b>Description</b>	<b>Example</b>
reason	String	M	256	Cancellation reason	Cancel reason
amount	Object	O			
value	String	M	16,2	Net amount of the transaction. If it's IDR then value includes 2 decimal digits. e.g. IDR 10.000,- will be placed with 10000.00	10000.00
currency	String	M	3	Currency (ISO 4217)	IDR
additionalInfo	Object	O	N/A	Additional information for custom use that are not provided by SNAP	{ "deviceId": "12345679237", "channel": "mobilephone"}

### Response Body

<b>Parameter</b>	<b>Data Type</b>	<b>Mandatory</b>	<b>Length</b>	<b>Description</b>	<b>Example</b>
responseCode	String	M	7	Response code	2007700
responseMessage	String	M	150	Response description	Successful

<b>Parameter</b>	<b>Data Type</b>	<b>Mandatory</b>	<b>Length</b>	<b>Description</b>	<b>Example</b>
originalPartnerReferenceNo	String	O	64	Original transaction identifier on service consumer system	2020102900 0000000000 01
originalReferenceNo	String	C	64	Original transaction identifier on service provider system	2020102977 7700000000 09
originalExternalId	String	O	32	Original External-ID on header message	3044378693 0722726463 2800979209 12
cancelTime	String	C	25	Cancel time  Format cancel time: (ISO 8601) YYYY-MM-DDThh:mm:ss  Must be filled upon successful cancel transaction	2020-10- 20T17:56:57 +07:00
transactionDate	String	O	25	Format transaction date: (ISO 8601) YYYY-MM-DDThh:mm:ss	2020-10-20 17:56:57+07: 00
additionalInfo	Object	O	N/A	Additional	{"deviceId": "12345679237",

<b>Parameter</b>	<b>Data Type</b>	<b>Mandatory</b>	<b>Length</b>	<b>Description</b>	<b>Example</b>
				information for custom use that are not provided by SNAP	"channel": "mobilephone"}

### Contoh Request

```

POST .../v1.0/qr/qr-mpm-cancel HTTP/1.2
Content-type: application/json
Authorization: Bearer
gp9HjjEj813Y9JGoqwOeOPWbnt4CUpvIJbU1mMU4a11MNDZ7Sg5u9a"
Authorization-Customer: Bearer
fa8sjjEj813Y9JGoqwOeOPWbnt4CUpvIJbU1mMU4a11MNDZ7Sg5u9a"
X-TIMESTAMP: 2020-12-23T08:10:11+07:00
X-SIGNATURE:
85be817c55b2c135157c7e89f52499bf0c25ad6eebe04a986e8c862561b19a5
ORIGIN: www.hostname.com
X-PARTNER-ID: 82150823919040624621823174737537
X-EXTERNAL-ID: 41807553358950093184162180797837
X-IP-ADDRESS: 172.24.281.24
X-DEVICE-ID: 09864ADCASA
X-LATITUDE: -6.108841
X-LONGITUDE: 106.7782137
CHANNEL-ID: 95221
{
  "originalPartnerReferenceNo": "202010290000000000000001",
  "originalReferenceNo": "202010297777000000000009",
  "originalExternalId": "30443786930722726463280097920912",
  "merchantId": "00007100010926",
  "subMerchantId": "310928924949487",
  "externalStoreId": "124928924949487",
  "reason": "cancel reason",
  "amount": {
    "value": "10000.00",
    "currency": "IDR"
  },
  "additionalInfo": {
    "deviceId": "12345679237",
    "channel": "mobilephone"
  }
}

```

## Contoh Response

Content-type: application/json

X-TIMESTAMP: 2020-12-23T08:10:18+07:00

```
{
  "responseCode": "2007700",
  "responseMessage": "Successful",
  "originalPartnerReferenceNo": "202010290000000000000001",
  "originalReferenceNo": "202010297777000000000009",
  "originalExternalId": "30443786930722726463280097920912",
  "cancelTime": "2020-10-20T17:56:57+07:00",
  "transactionDate": "2020-12-23T08:37:11+07:00",
  "additionalInfo": {
    "deviceId": "12345679237",
    "channel": "mobilephone"
  }
}
```

## h. Refund Payment

### Informasi Umum

<b>Service Code</b>	78
<b>Name</b>	API Refund Payment
<b>Version</b>	1.0
<b>HTTP Method</b>	POST
<b>Path</b>	.../{version}/qr/qr-mpm-refund

### Request Body

<b>Parameter</b>	<b>Data Type</b>	<b>Mandatory</b>	<b>Length</b>	<b>Description</b>	<b>Example</b>
merchantId	String	O	64	Merchant identifier that is unique per each merchant	00007100010926
subMerchantId	String	O	32	Sub merchant ID	310928924949487
externalStoreId	String	O	64	External Store ID	124928924949487
originalPartnerReferenceNo	String	M	64	Original transaction identifier on service consumer system	20201029000000000001
originalReferenceNo	String	O	64	Original transaction identifier on service provider system	2020102977770000000009
originalExternalId	String	O	32	Original Customer	10052019

<b>Parameter</b>	<b>Data Type</b>	<b>Mandatory</b>	<b>Length</b>	<b>Description</b>	<b>Example</b>
				Reference Number	
partnerRefundNo	String	M	64	ReferenceNumber from PJP AIS for the refund.	23985091820 4981205970
refundAmount	Object	O			
value	String	M	16,2	Refund amount of the transaction. If it's IDR then value includes 2 decimal digits. e.g. IDR 10.000,- will be placed with 10000.00	10000.00
currency	String	M	3	Currency (ISO 4217)	IDR
reason	String	O	256	Refund reason.	Customer complain.
additionalInfo	Object	O	N/A	Additional information for custom use that are not provided by SNAP	{"deviceId": "12345679237", "channel": "mobilephone"}

## Response Body

<b>Parameter</b>	<b>Data Type</b>	<b>Mandatory</b>	<b>Length</b>	<b>Description</b>	<b>Example</b>
responseCode	String	M	7	Response code	2007800
responseMessage	String	M	150	Response description	Successful
originalPartnerReferenceNo	String	O	64	Original transaction identifier on service consumer system	2020102900 0000000000 01
originalReferenceNo	String	O	64	Original transaction identifier on service provider system	2020102977 7700000000 09
originalExternalId	String	O	32	Original Customer Reference Number	10052019
refundNo	String	M	64	Refund Number	REF993883
partnerRefundNo	String	O	64	ReferenceNumber from PJP AIS for the refund.	2398509182 0498120597 0
refundAmount	Object	O			
value	String	M	16,2	Refund amount of the transaction. If it's IDR then value includes 2 decimal digits.	10000.00



<b>Parameter</b>	<b>Data Type</b>	<b>Mandatory</b>	<b>Length</b>	<b>Description</b>	<b>Example</b>
				e.g. IDR 10.000,- will be placed with 10000.00	
currency	String	M	3	Currency	IDR
refundTime	String	M	25	Refund time. Refund time format: (ISO 8601) YYYY-MM-DDThh:mm:ss	2020-12-21T17:21:41+07:00
additionalInfo	Object	O	N/A	Additional information for custom use that are not provided by SNAP	

### Contoh Request

```

POST .../v1.0/qr/qr-mpm-refund HTTP/1.2
Content-type: application/json
Authorization: Bearer
gp9HjjEj813Y9JGoqwOeOPWbnt4CUpvIJbU1mMU4a11MNDZ7Sg5u9a"
Authorization-Customer: Bearer
fa8sjjEj813Y9JGoqwOeOPWbnt4CUpvIJbU1mMU4a11MNDZ7Sg5u9a"
X-TIMESTAMP: 2020-12-23T08:10:11+07:00
X-SIGNATURE:
85be817c55b2c135157c7e89f52499bf0c25ad6eebe04a986e8c862561b19a5
ORIGIN: www.hostname.com
X-PARTNER-ID: 82150823919040624621823174737537
X-EXTERNAL-ID: 41807553358950093184162180797837
X-IP-ADDRESS: 172.24.281.24
X-DEVICE-ID: 09864ADCASA
X-LATITUDE: -6.108841
X-LONGITUDE: 106.7782137
CHANNEL-ID: 95221

```

```
{
```

```
"merchantId":"00007100010926",
"subMerchantId":"310928924949487",
"externalStoreId":"124928924949487",
"originalPartnerReferenceNo":"202010290000000000000001",
"originalReferenceNo":"202010297777000000000009",
"originalExternalId":"10052019",
"partnerRefundNo":"239850918204981205970",
"refundAmount":{
  "value":"10000.00",
  "currency":"IDR"
},
"reason":"Customer complain",
"additionalInfo":null
}
```

### Contoh Response

Content-type: application/json  
X-TIMESTAMP: 2020-12-23T08:10:18+07:00

```
{
  "responseCode":"2007800",
  "responseMessage":"Successful",
  "originalPartnerReferenceNo":"202010290000000000000001",
  "originalReferenceNo":"202010297777000000000009",
  "originalExternalId":"10052019",
  "refundNo":"REF993883",
  "partnerRefundNo":"239850918204981205970",
  "refundAmount":{
    "value":"10000.00",
    "currency":"IDR"
  },
  "refundTime":"2020-12-21T17:21:41+07:00",
  "additionalInfo":null
}
```

### 4.3.6. API Transaction Status Inquiry

#### Sequence Diagram

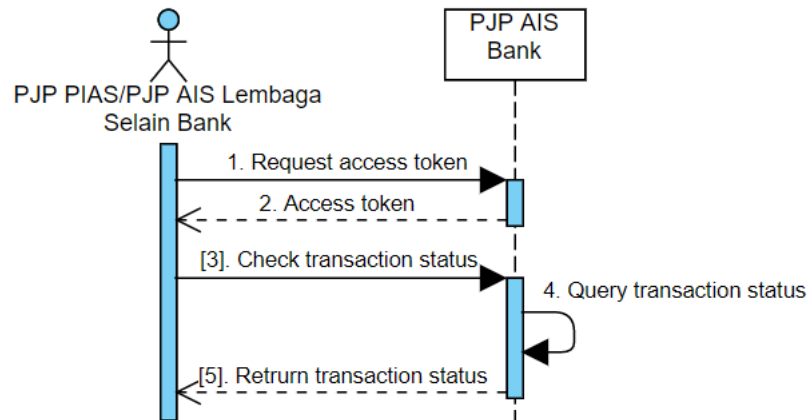

Sequence Diagram API Transaction Status Inquiry

#### Informasi Umum

<b>Service Code</b>	53
<b>Name</b>	API Transaction Status Inquiry
<b>Version</b>	1.0
<b>HTTP Method</b>	POST
<b>Path</b>	.../{version}/qr/qr-mpm-status

#### Request Body

<i>Parameter</i>	<i>Data Type</i>	<i>Mandatory</i>	<i>Length</i>	<i>Description</i>	<i>Example</i>
originalPartnerReferenceNo	String	O	64	Original transaction identifier on service consumer system	20201029000000000001
originalReferenceNo	String	O	64	Original transaction identifier on	2020102977770000000009

<b>Parameter</b>	<b>Data Type</b>	<b>Mandatory</b>	<b>Length</b>	<b>Description</b>	<b>Example</b>
				service provider system	
originalExternalId	String	O	32	Original External-ID on header message	3044378693 0722726463 2800979209 12
serviceCode	String	M	2	Transaction type indicator. Service code of the transaction that needs to be checked (original transaction).	49/50
transactionDate	String	O	25	Format transaction date : (ISO 8601) YYYY-MM-DDThh:mm:ss	2019-07-03T12:08:56+07:00
amount	Object	O			
value	String	M	16,2	Net amount of the transaction. If it's IDR then value includes 2 decimal digits. e.g. IDR 10.000,- will be	10000.00

<b>Parameter</b>	<b>Data Type</b>	<b>Mandatory</b>	<b>Length</b>	<b>Description</b>	<b>Example</b>
				placed with 10000.00	
currency	String	M	3	Currency (ISO 4217)	IDR
additionalInfo	Object	O	N/A	Additional information for custom use that are not provided by SNAP	{ "deviceId": "12345679237", "channel": "mobilephone"}

### Response Body

<b>Parameter</b>	<b>Data Type</b>	<b>Mandatory</b>	<b>Length</b>	<b>Description</b>	<b>Example</b>
responseCode	String	M	7	Response code	2005300
responseMessage	String	M	150	Response description	Successful
originalReferenceNo	String	C	64	Original transaction identifier on service provider system.  Must be filled upon successful original transaction	2020102977 7700000000 09

<b>Parameter</b>	<b>Data Type</b>	<b>Mandatory</b>	<b>Length</b>	<b>Description</b>	<b>Example</b>
originalPartnerReferenceNo	String	O	64	Original transaction identifier on service consumer system	2020102900 0000000000 01
originalExternalId	String	O	32	Original External-ID on header message	3044378693 0722726463 2800979209 12
serviceCode	String	M	2	Transaction type indicator. Service code of the transaction that needs to be checked (original transaction).	49/50
latestTransactionStatus	String	M	2	<b>00</b> = Success <b>01</b> = Initiated <b>02</b> = Paying <b>03</b> = Pending <b>04</b> = Refunded <b>05</b> = Canceled <b>06</b> = Failed <b>07</b> = Not found	00
transactionStatusDesc	String	O	50	Description status transaction	success

<b>Parameter</b>	<b>Data Type</b>	<b>Mandatory</b>	<b>Length</b>	<b>Description</b>	<b>Example</b>
originalResponseCode	String	O	7	Original Response code	2004900 / 2005000
originalResponseMessage	String	O	150	Original Response description	Successful
sessionId	String	O	25	Transaction invoice ID	883737GHY8839
requestId	String	O	25	Transaction request ID	3763773
transactionDate	String	O	25	Format transaction date : (ISO 8601) YYYY-MM-DDThh:mm:ss	2019-07-03T12:08:56+07:00
amount	Object	O			
value	String	M	16,2	Net amount of the transaction. If it's IDR then value includes 2 decimal digits. e.g. IDR 10.000,- will be placed with 10000.00	12345678.00
currency	String	M	3	Currency (ISO 4217)	IDR
additionalInfo	Object	O	N/A	Additional information for	{"deviceId": "12345679237",

<b>Parameter</b>	<b>Data Type</b>	<b>Mandatory</b>	<b>Length</b>	<b>Description</b>	<b>Example</b>
				custom use that are not provided by SNAP	"channel": "mobilephone"}

### Contoh Request

```
POST .../v1.0/qr/qr-mpm-status HTTP/1.2
Content-type: application/json
Authorization: Bearer
gp9HjjEj813Y9JGoqwOeOPWbnt4CUpvIJbU1mMU4a11MNDZ7Sg5u9a"
Authorization-Customer: Bearer
fa8sjjEj813Y9JGoqwOeOPWbnt4CUpvIJbU1mMU4a11MNDZ7Sg5u9a"
X-TIMESTAMP: 2020-12-21T18:02:11+07:00
X-SIGNATURE:
85be817c55b2c135157c7e89f52499bf0c25ad6eebe04a986e8c862561b19a5
ORIGIN: www.hostname.com
X-PARTNER-ID: 82150823919040624621823174737537
X-EXTERNAL-ID: 41807553358950093184162180797837
X-IP-ADDRESS: 172.24.281.24
X-DEVICE-ID: 09864ADCASA
X-LATITUDE: -6.1617169
X-LONGITUDE: 106.6643946
CHANNEL-ID: 95221
```

```
{
  "originalPartnerReferenceNo": "202010290000000000000001",
  "originalReferenceNo": "202010297777000000000009",
  "originalExternalId": "30443786930722726463097920912",
  "serviceCode": "49",
  "transactionDate": "2019-07-03T12:08:56+07:00",
  "amount": {
    "value": "10000.00",
    "currency": "IDR"
  },
  "additionalInfo": {
    "deviceId": "12345679237",
    "channel": "mobilephone"
  }
}
```

### Contoh Response

```
Content-type: application/json
X-TIMESTAMP: 2020-12-21T17:55:21+07:00
```



```
{
  "responseCode": "2005300",
  "responseMessage": "Successful",
  "originalReferenceNo": "20201029777700000000009",
  "originalPartnerReferenceNo": "20201029000000000000001",
  "originalExternalId": "30443786930722726463097920912",
  "serviceCode": "49",
  "latestTransactionStatus": "00",
  "transactionStatusDesc": "success",
  "originalResponseCode": "2004900",
  "originalResponseMessage": "Successful",
  "sessionId": "883737GHY8839",
  "requestId": "3763773",
  "transactionDate": "2019-07-03T12:08:56+07:00",
  "amount": {
    "value": "12345678.00",
    "currency": "IDR"
  },
  "additionalInfo": {
    "deviceId": "12345679237",
    "channel": "mobilephone"
  }
}
```

## 5. KATEGORI V: API TRANSFER DEBIT

API Transfer Debit digunakan untuk melakukan pemindahanbukuan dana dari satu rekening ke rekening lain baik dalam PJP AIS yang sama maupun PJP AIS yang berbeda yang diinisiasi oleh pihak penerima (pihak terkredit).

### 5.1. SKENARIO PENGGUNAAN API TRANSFER DEBIT

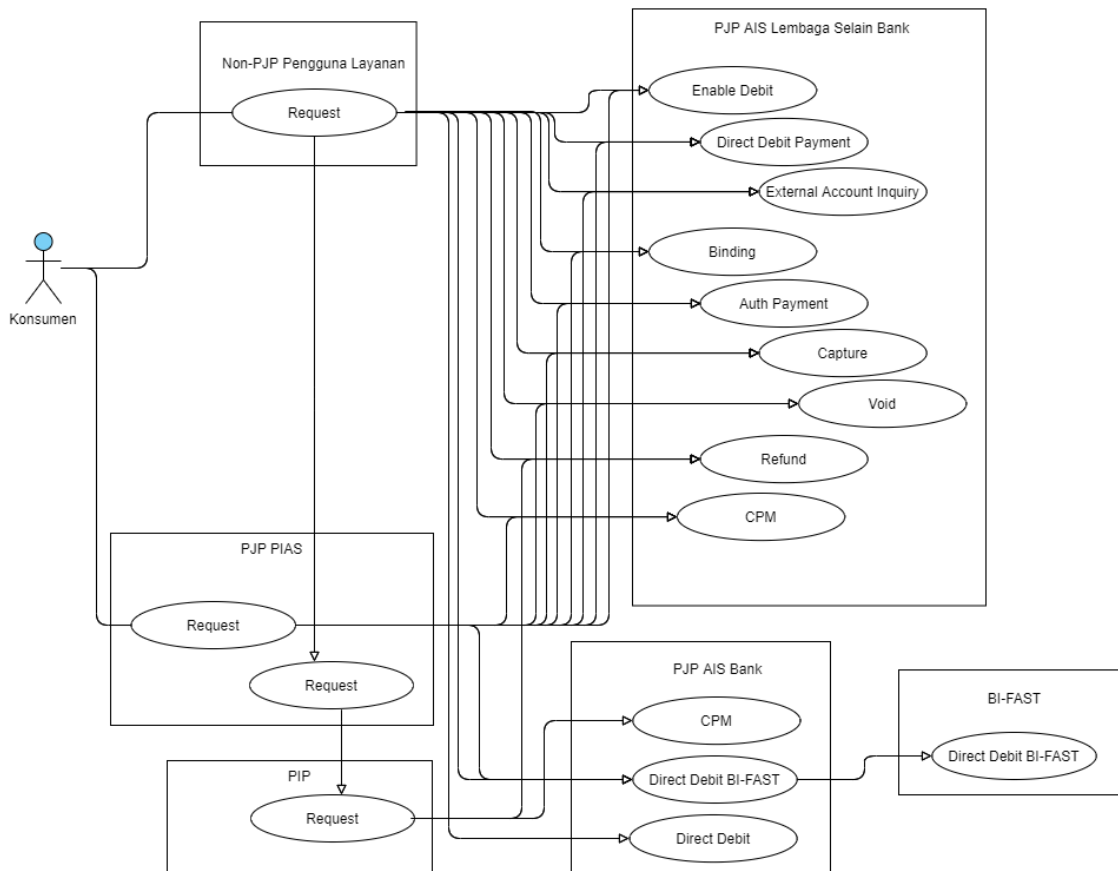

*Use Case Diagram API Transfer Debit*

Merujuk pada *use case diagram*, pemilik rekening yaitu Konsumen, Non-PJP Pengguna Layanan, serta PJP PIAS, dapat melakukan pemindahan dana atas rekeningnya pada PJP AIS Bank menggunakan API Direct Debit dan API CPM. Sedangkan pemindahbukuan dana pada rekening PJP AIS Lembaga Selain Bank menggunakan API Direct Debit, API CPM, dan API Auth Payment.

API Transfer Debit dapat digunakan dalam sejumlah skema sebagai berikut:

**Skema 1: Konsumen – Non-PJP Pengguna Layanan / PJP PIAS – PJP AIS Lembaga Selain Bank**

Dalam skema ini, konsumen dapat melakukan pembayaran kepada Non-PJP Pengguna Layanan menggunakan dana yang berasal dari rekening Konsumen pada PJP AIS Lembaga Selain Bank, menggunakan API Direct Debit Payment atau API Auth Payment. Sebelum pendebitan dapat dilakukan, Konsumen melakukan account binding antara rekeningnya pada PJP AIS Lembaga Selain Bank dengan akun pada Non-PJP Pengguna Layanan (merujuk pada Bagian I untuk account binding).

- Untuk transaksi direct debit, Non-PJP Pengguna Layanan atau PJP PIAS mendapatkan persetujuan dari Konsumen untuk dilakukan pendebitan (proses binding) atas kartu/rekeningnya menggunakan API enable direct debit. Non-PJP Pengguna Layanan dapat menggunakan API disable direct debit apabila konsumen mencabut persetujuan pendebitan kartu/rekeningnya (proses unbinding).
- Untuk transaksi auth payment, Non-PJP Pengguna Layanan maupun PJP PIAS dapat meminta PJP AIS untuk menahan sejumlah nominal tertentu untuk keperluan pembelian barang dan/atau jasa yang nilainya belum ditentukan menggunakan API Auth Payment sesuai dengan otorisasi yang diberikan Konsumen. Pada penyelesaian transaksi, pendebitan dilakukan sejumlah nilai transaksi menggunakan API Auth Capture, sedangkan kelebihan nominal yang ditahan dikembalikan menggunakan API Auth Void. Apabila terdapat kendala pada transaksi tersebut, dana yang ditahan dapat dikembalikan menggunakan API Auth Refund.

**Skema 2: Konsumen – Non-PJP Pengguna Layanan / PJP PIAS – PJP AIS Bank**

Dalam skema ini, konsumen dapat melakukan pembayaran kepada Non-PJP Pengguna Layanan menggunakan dana yang berasal dari rekening Konsumen pada PJP AIS Bank, menggunakan API Direct Debit Payment. Sebelum pendebitan dapat dilakukan, Konsumen melakukan card registration atau account binding antara kartu

atau rekeningnya pada PJP AIS Bank dengan akun pada Non-PJP Pengguna Layanan (merujuk pada Bagian I untuk card registration atau account binding).

- Untuk transaksi direct debit, Non-PJP Pengguna Layanan, atau PJP PIAS mendapatkan persetujuan dari Konsumen untuk dilakukan pendebitan (proses binding) atas kartu/rekeningnya menggunakan API enable direct debit. Non-PJP Pengguna Layanan dapat menggunakan API disable direct debit apabila konsumen mencabut persetujuan pendebitan kartu/rekeningnya (proses unbinding).

**Skema 3: Konsumen – Non-PJP Pengguna Layanan – PJP AIns/PJP PIAS – PIP (Switching) – PJP AIS Bank/PJP AIS Lembaga Selain Bank**

- Skema ini merupakan transaksi menggunakan QR CPM. Konsumen dapat melakukan pembayaran kepada Non-PJP Pengguna Layanan menggunakan dana yang berasal dari rekening konsumen pada PJP AIS Bank atau PJP AIS Lembaga Selain Bank, menggunakan API CPM Payment.
- Sebelum pendebitan dapat dilakukan, konsumen memberikan otorisasi kepada PJP AIS Bank atau PJP AIS Lembaga Selain Bank sebagai penatausaha rekening menggunakan API Binding.
- Transaksi pembayaran ini dilakukan menggunakan QR yang dihasilkan dari API Generate QR.
- Apabila terjadi gangguan atau kesalahan dalam bertransaksi, Non-PJP Pengguna Layanan dapat melakukan pengecekan status transaksi menggunakan API Query Payment.
- Non-PJP Pengguna Layanan dapat membatalkan transaksi menggunakan API Cancel Payment atas permintaan Konsumen.

**Skema 4: Non-PJP Pengguna Layanan / PJP PIAS / PJP AIS Lembaga Selain Bank – PJP AIS Bank – PIP (BI-FAST)**

- Skema ini digunakan pada layanan Direct Debit BI-FAST yaitu pendebitan secara berkala rekening nasabah tertagih oleh *biller*, umumnya dalam rangka pembayaran atas penggunaan layanan (listrik, telepon, dll). Nasabah memberikan *consent* pendebitan rekeningnya dalam bentuk *e-mandate*.

- Registrasi e-Mandate dilakukan nasabah tertagih, dengan memberikan informasi tagihan yang akan dibayar secara berkala. Informasi ini diteruskan ke bank penagih untuk dilakukan validasi terkait informasi *biller*.
- Direct Debit Transfer diinisiasi oleh biller dengan mengirimkan daftar billing kepada bank. Selanjutnya bank menginisiasi debit transfer ke bank nasabah melalui BI-Fast.
- Notify Direct Debit Transfer digunakan untuk menginformasikan status seluruh transfer individual yang terdapat dalam direct debit message.

## 5.2. SPESIFIKASI API TRANSFER DEBIT

### 5.2.1. API Direct Debit

#### Sequence Diagram

#### Redirect (web check out with otp)

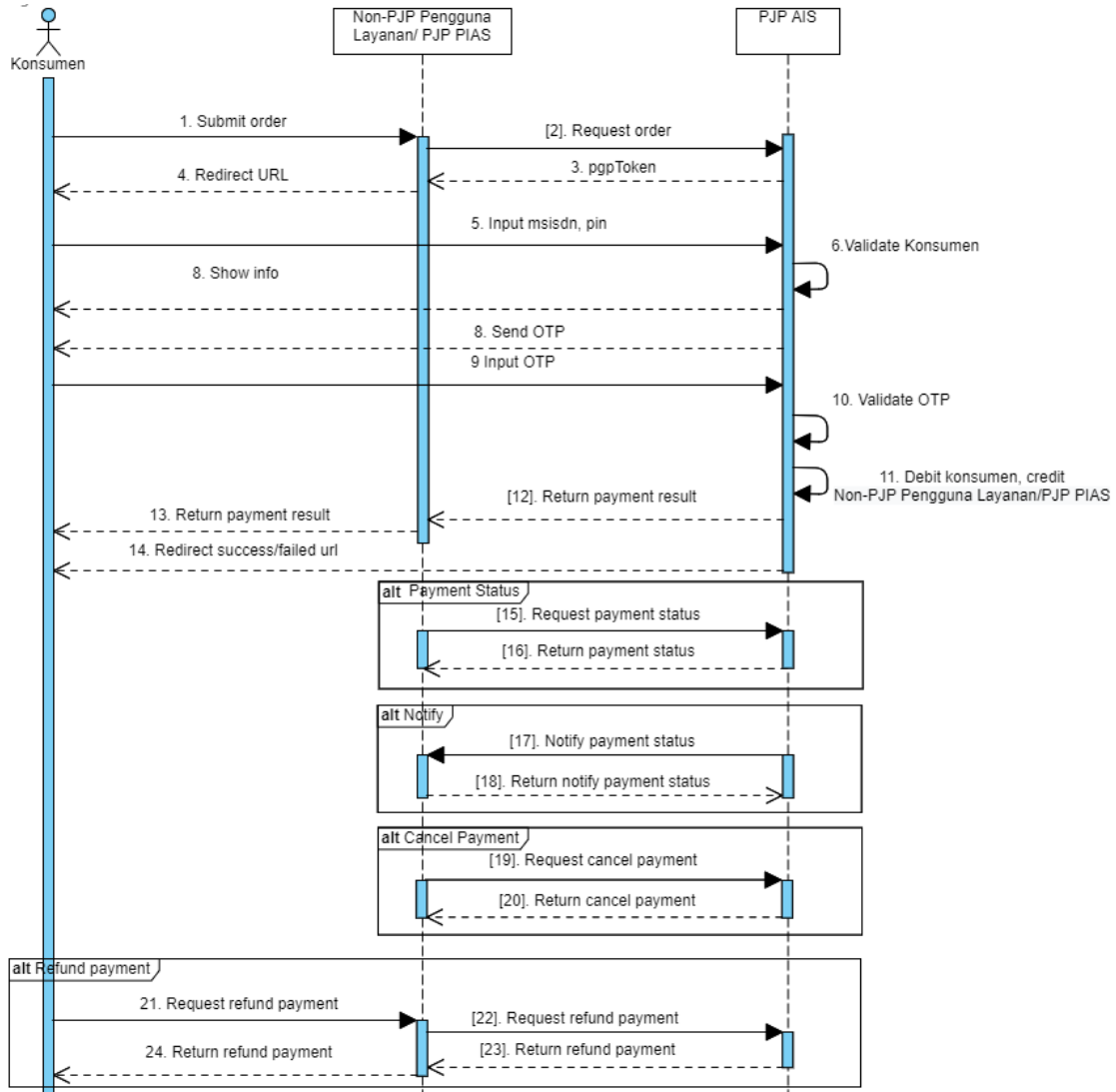

Sequence Diagram Redirect (web check out with otp)

## Redirect (web check out without otp)

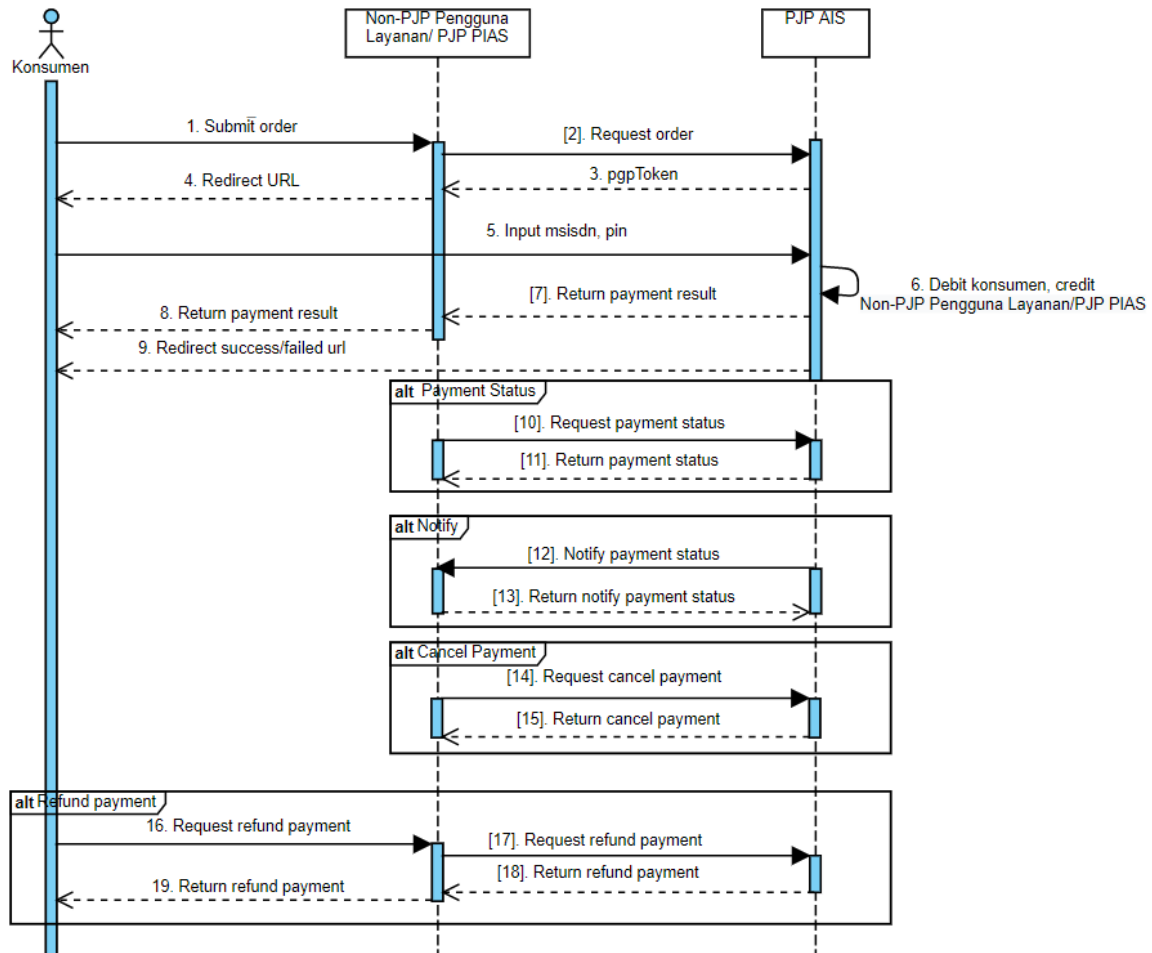

Sequence Diagram Redirect (web check out without otp)

# Host to Host

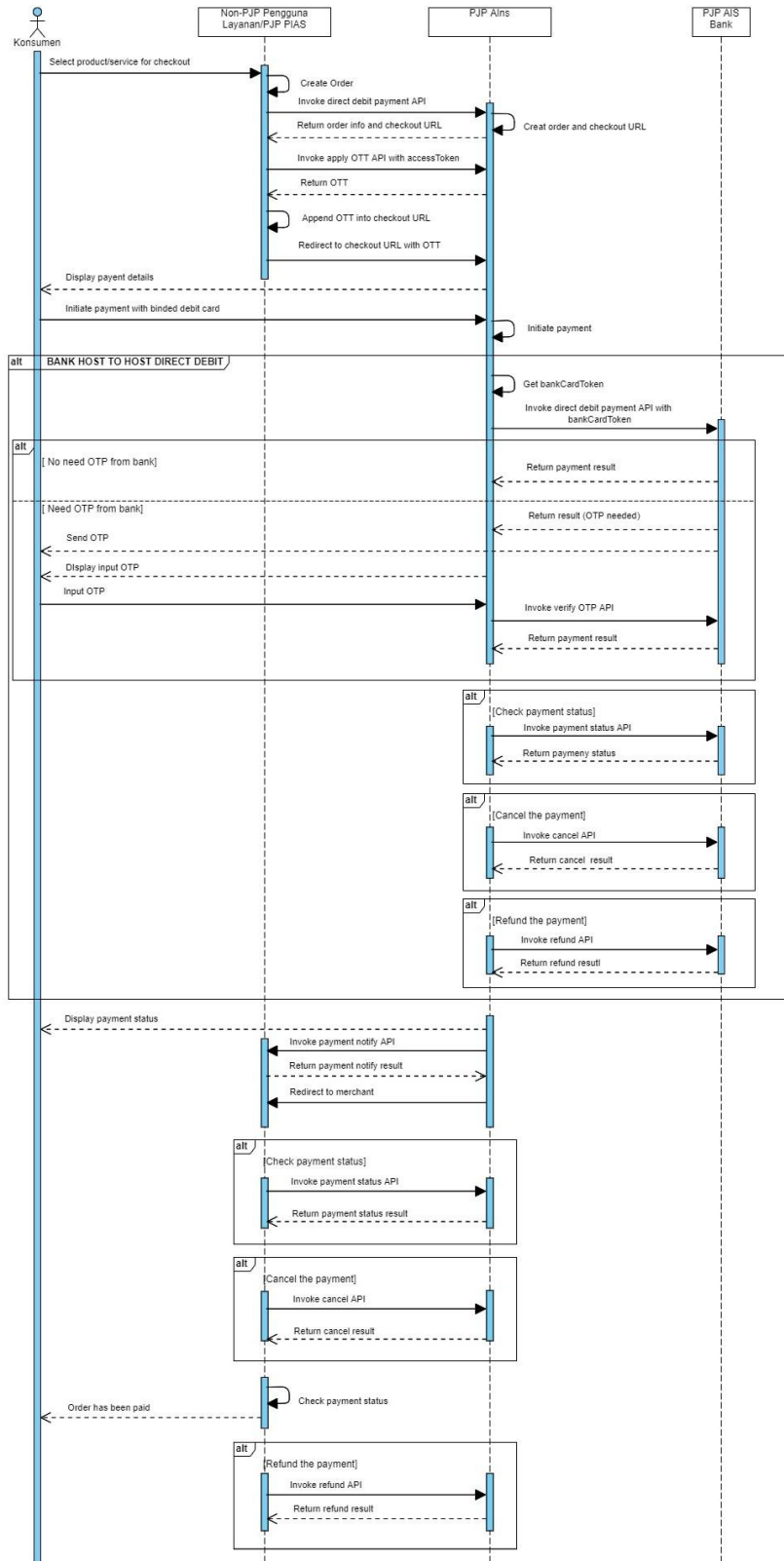



## Sequence Diagram API Direct Debit-Payment Host to Host

### App Link

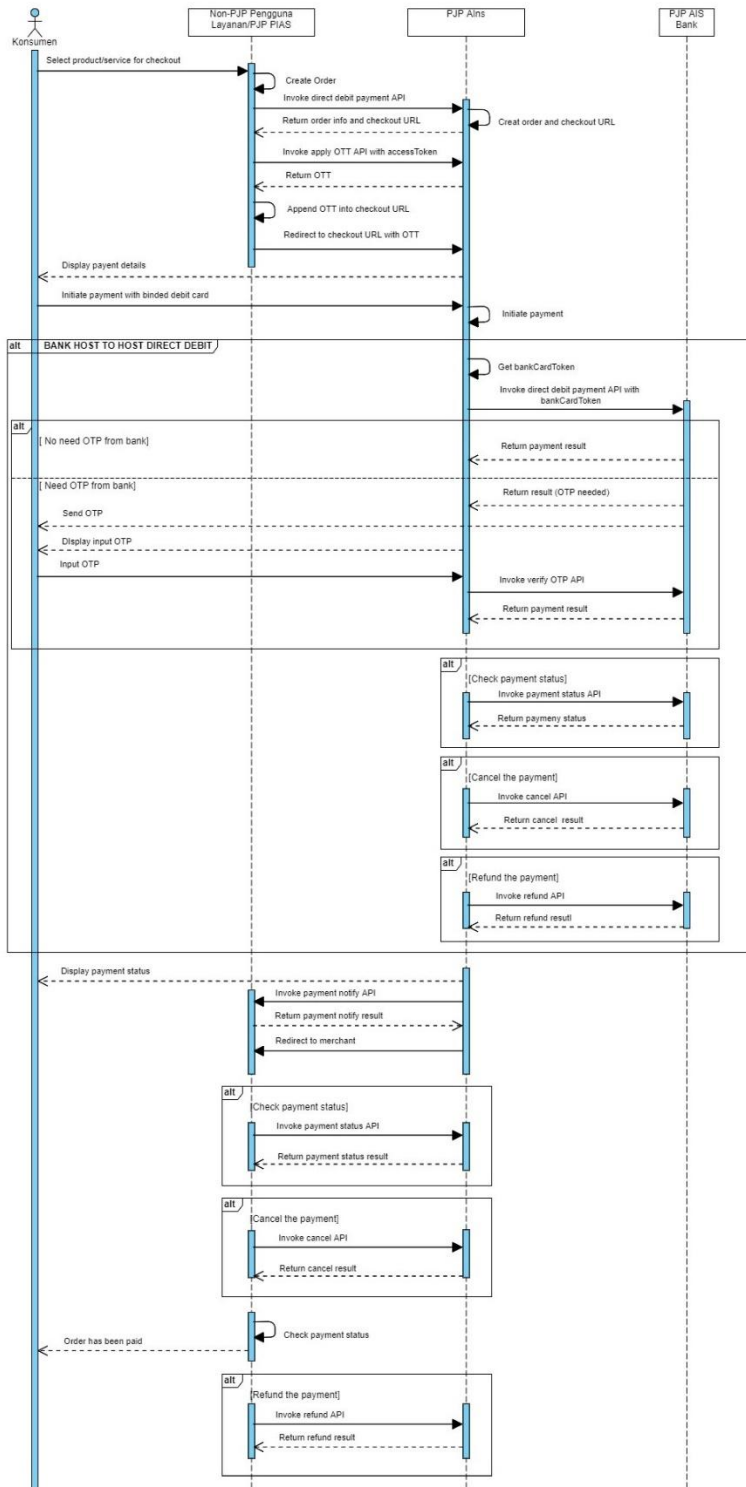

Sequence Diagram API Direct Debit-App Link

## a. Direct Debit Payment

### Informasi Umum

<b>Service Code</b>	54
<b>Name</b>	API Direct Debit Payment
<b>Version</b>	1.0
<b>HTTP Method</b>	POST
<b>Path</b>	.../{version}/debit/payment-host-to-host

### Request Body

<i>Parameter</i>	<i>Data Type</i>	<i>Mandatory</i>	<i>Length</i>	<i>Description</i>	<i>Example</i>
partnerReferenceNo	String	M	64	Transaction identifier on service consumer system	2020102900 0000000000 01
bankCardToken	String	O	128	Card token for payment	0000710001 0926
chargeToken	String	O	40	string code for verification OTP	abcd6361726 4746f6b656e
otp	String	O	8	OTP Code / Passcode	12345678
otpTrxCode	String	O	2	Purpose of otp	12345678
merchantId	String	O	64	Merchant identifier that is unique per each merchant	2348918230 3312
terminalId	String	O	64	Terminal ID	4891823033 12
journeyId	String	O	64	Merchant ID	8610237130 17210

<b>Parameter</b>	<b>Data Type</b>	<b>Mandatory</b>	<b>Length</b>	<b>Description</b>	<b>Example</b>
subMerchantId	String	O	32	Sub merchant ID	3109289249 49487
amount	Object	O			
value	String	M	16,2	Net amount of the transaction. If it's IDR then value includes 2 decimal digits. e.g. IDR 10.000,- will be placed with 10000.00	12345678.00
currency	String	M	3	Currency (ISO 4217)	IDR
urlParams	Array of Objects	O			
url	String	M	512	The URL	<a href="https://test.bi.go.id/v1/test">https://test.bi.go.id/v1/test</a>
type	String	M	32	URL Type PAY_RETURN / PAY_NOTIFY	PAY_RETURN
isDeeplink	String	M	1	Whether the URL is a deeplink URL or not  <b>Y</b> = Yes <b>N</b> = No	Y

<b>Parameter</b>	<b>Data Type</b>	<b>Mandatory</b>	<b>Length</b>	<b>Description</b>	<b>Example</b>
externalStoreId	String	O	64	Store ID to indicate to which store this payment belongs to.	2398401982 40795109
validUpTo	String	O	25	The time when the payment will be automatically expired. ISO 8601	2020-12-23T07:44:11+07:00
pointOfInitiation	String	O	20	used for getting more info regarding source of request of the user	Mobile app
feeType	String	O	25	To whom the fee will be charged  <b>OUR</b> = Fee is charged to the sender (default) <b>BEN</b> = Fee is charged to the recipient <b>SHA   1000</b> = Fee is shared between sender and recipient, with sender is	SHA   1000

<b>Parameter</b>	<b>Data Type</b>	<b>Mandatory</b>	<b>Length</b>	<b>Description</b>	<b>Example</b>
				charged Rp 1.000,00 and the recipient will be charged the rest	
disabledPayMethods	String	O	64	Payment method(s) that cannot be used for this payment	CREDIT_CARD
payOptionDetails	Array of Objects	O		Payment option that will be used for this payment	
payMethod	String	M	64	Payment Method. e.g. CREDIT_CARD	CREDIT_CARD
payOption	String	M	64	Payment option which shows the provider of this payment e.g. CREDIT_CARD_VISA	CREDIT_CARD_VISA
transAmount	Object	O			
value	String	M	16,2	Transaction amount that will be paid using this payment method If it's IDR then value includes 2 decimal digits.	12345678.00

<b>Parameter</b>	<b>Data Type</b>	<b>Mandatory</b>	<b>Length</b>	<b>Description</b>	<b>Example</b>
				e.g. IDR 10.000,- will be placed with 10000.00	
currency	String	M	3	Currency (ISO 4217)	IDR
feeAmount	Object	O			
value	String	M	16,2	Fee amount that will be paid using this payment method. If it's IDR then value includes 2 decimal digits. e.g. IDR 10.000,- will be placed with 10000.00	12345678.00
currency	String	M	3	Currency (ISO 4217)	IDR
cardToken	String	O	64	Card token used for this payment.	d89ca90ua90sd80as9809
merchantToken	String	O	64	Merchant token used for this payment.	a90ua90sd80d89cas9809
additionalInfo	Object	O	N/A	Additional information for custom use that are not provided by SNAP for	{"deviceId": "12345679237", "channel": "mobilephone"}

<b>Parameter</b>	<b>Data Type</b>	<b>Mandatory</b>	<b>Length</b>	<b>Description</b>	<b>Example</b>
				payOptionDetails	
additionalInfo	Object	O	N/A	Additional information for custom use that are not provided by SNAP	{"deviceId": "12345679237", "channel": "mobilephone"}

### Response Body

<b>Parameter</b>	<b>Data Type</b>	<b>Mandatory</b>	<b>Length</b>	<b>Description</b>	<b>Example</b>
responseCode	String	M	7	Response code	2005400
responseMessage	String	M	150	Response description	Successful
referenceNo	String	C	64	Transaction identifier on service provider system.  Must be filled upon successful transaction	2020102977 7700000000 09
partnerReferenceNo	String	O	64	Transaction identifier on service consumer system	2020102900 0000000000 01
approvalCode	String	O	20		2010390002 00
appRedirectUrl	String	O	2048	Returns an URL scheme to PJP AIS payment	https://pjsp.com/app?biz

<b>Parameter</b>	<b>Data Type</b>	<b>Mandatory</b>	<b>Length</b>	<b>Description</b>	<b>Example</b>
				page in native app.	No=REF993883&...
webRedirect Url	String	O	2048	Returns a universal link to PJP AIS payment page. This link is recommended when the Client is unable to implement a check for whether PJP AIS app is installed on the user's device before redirect.	https://pjsp.com/universal?bizNo=REF993883&...
additionalInfo	Object	O	N/A	Additional information for custom use that are not provided by SNAP	{"deviceId": "12345679237", "channel": "mobilephone"}

### Contoh Request

```

POST .../v1.0/debit/payment-host-to-host HTTP/1.2
Content-type: application/json
Authorization: Bearer
gp9HjjEj813Y9JGoqwOeOPWbnt4CUpvIJbU1mMU4a11MNDZ7Sg5u9a"
Authorization-Customer: Bearer
fa8sjjEj813Y9JGoqwOeOPWbnt4CUpvIJbU1mMU4a11MNDZ7Sg5u9a"
X-TIMESTAMP: 2020-12-23T07:44:11+07:00

```



X-SIGNATURE:  
85be817c55b2c135157c7e89f52499bf0c25ad6eeeb04a986e8c862561b19a5  
ORIGIN: www.hostname.com  
X-PARTNER-ID: 82150823919040624621823174737537  
X-EXTERNAL-ID: 41807553358950093184162180797837  
X-IP-ADDRESS: 172.24.281.24  
X-DEVICE-ID: 09864ADCASA  
X-LATITUDE: -6.1617169  
X-LONGITUDE: 106.6643946  
CHANNEL-ID: 95221

```
{
  "partnerReferenceNo": "202010290000000000000001",
  "bankCardToken": "00007100010926",
  "otp": "12345678",
  "merchantId": "23489182303312",
  "terminalId": "489182303312",
  "journeyId": "861023713017210",
  "subMerchantId": "310928924949487",
  "amount": {
    "value": "12345678.00",
    "currency": "IDR"
  },
  "urlParams": [
    {
      "url": "https://test1.bi.go.id/v1/test",
      "type": "PAY_RETURN",
      "isDeeplink": "Y"
    },
    {
      "url": "https://test2.bi.go.id/v1/test",
      "type": "PAY_RETURN",
      "isDeeplink": "Y"
    }
  ],
  "externalStoreId": "239840198240795109",
  "validUpTo": "2020-12-23T07:44:11+07:00",
  "pointOfInitiation": "Mobile App",
  "feeType": "SHA|1000",
  "disabledPayMethods": "CREDIT_CARD",
  "payOptionDetails": [
    {
      "payMethod": "CREDIT_CARD",
      "payOption": "CREDIT_CARD_VISA",
      "transAmount": {
        "value": "12345678.00",
        "currency": "IDR"
      }
    }
  ]
}
```

```

    },
    "feeAmount":{
      "value":"12345678.00",
      "currency":"IDR"
    },
    "cardToken":"d89ca90ua90sd80as9809",
    "merchantToken":"a90ua90sd80d89cas9809",
    "additionalInfo":{
      "deviceId":"12345679237",
      "channel":"mobilephone"
    }
  },
  {
    "payMethod":"CREDIT_CARD",
    "payOption":"CREDIT_CARD_MASTER",
    "transAmount":{
      "value":"12345678.00",
      "currency":"IDR"
    },
    "feeAmount":{
      "value":"12345678.00",
      "currency":"IDR"
    },
    "cardToken":"d89ca90ua90sd80as9809",
    "merchantToken":"a90ua90sd80d89cas9809",
    "additionalInfo":{
      "deviceId":"12345679237",
      "channel":"mobilephone"
    }
  }
]
"additionalInfo":{
  "deviceId":"12345679237",
  "channel":"mobilephone"
}
}

```

## Contoh Response

Content-type: application/json  
X-TIMESTAMP: 2020-12-23T07:44:16+07:00

```

{
  "responseCode":"20054000",
  "responseMessage":"Successful",
  "referenceNo":"2020102977770000000009",
  "partnerReferenceNo":"2020102900000000000001",
  "approvalCode":"201039000200",
  "appRedirectUrl":"https://pjsp.com/app?bizNo=REF993883&...",

```

```
"webRedirectUrl":"https://pjsp.com/universal?bizNo=REF993883&
...",
"additionalInfo":{
  "deviceId":"12345679237",
  "channel":"mobilephone"
}
}
```

## b. Payment Status

### Informasi Umum

<b>Service Code</b>	55
<b>Name</b>	API Direct Debit Payment Status
<b>Version</b>	1.0
<b>HTTP Method</b>	POST
<b>Path</b>	.../{version}/debit/status

### Request Body

<i>Parameter</i>	<i>Data Type</i>	<i>Mandatory</i>	<i>Length</i>	<i>Description</i>	<i>Example</i>
originalPartnerReferenceNo	String	O	64	Original transaction identifier on service consumer system	20201029000000000001
originalReferenceNo	String	O	64	Original transaction identifier on service provider system	2020102977770000000009
originalExternalId	String	O	32	Original External-ID on header message	30443786930722726463280097920912
serviceCode	String	M	2	Transaction type indicator. Service code of the transaction that needs to be checked (original transaction).	54

<b>Parameter</b>	<b>Data Type</b>	<b>Mandatory</b>	<b>Length</b>	<b>Description</b>	<b>Example</b>
transactionDate	String	O	25	Format transaction date : (ISO 8601) YYYY-MM-DDThh:mm:ss	2020-12-21T14:56:11+07:00
amount	Object	O			
value	String	M	16,2	Net amount of the transaction. If it's IDR then value includes 2 decimal digits. e.g. IDR 10.000,- will be placed with 10000.00	12345678.00
currency	String	M	3	Currency (ISO 4217)	IDR
merchantId	String	O	64	Merchant identifier that is unique per each merchant	23489182303312
subMerchantId	String	O	32	Sub merchant ID	23489182303312
externalStoreId	String	O	64	External Store ID for merchant	183908924912387
additionalInfo	Object	O	N/A	Additional information for custom use that are not	{"deviceId": "12345679237", "channel": "mobilephone"}

<b>Parameter</b>	<b>Data Type</b>	<b>Mandatory</b>	<b>Length</b>	<b>Description</b>	<b>Example</b>
				provided by SNAP	

### Response Body

<b>Parameter</b>	<b>Data Type</b>	<b>Mandatory</b>	<b>Length</b>	<b>Description</b>	<b>Example</b>
responseCode	String	M	7	Response code	2005500
responseMessage	String	M	150	Response description	Successful
originalReferenceNo	String	C	64	Original transaction identifier on service provider system.  Must be filled upon successful original transaction	2020102977 7700000000 09
originalPartnerReferenceNo	String	O	64	Original transaction identifier on service consumer system	2020102900 0000000000 01
approvalCode	String	O	20	Approval Code	2010390002 00
originalExternalId	String	O	32	Original External-ID on header message	3044378693 0722726463 2800979209 12

<b>Parameter</b>	<b>Data Type</b>	<b>Mandatory</b>	<b>Length</b>	<b>Description</b>	<b>Example</b>
serviceCode	String	M	2	Transaction type indicator. Service code of the transaction that needs to be checked (original transaction).	54
latestTransactionStatus	String	M	2	<b>00</b> = Success <b>01</b> = Initiated <b>02</b> = Paying <b>03</b> = Pending <b>04</b> = Refunded <b>05</b> = Canceled <b>06</b> = Failed <b>07</b> = Not found	00
transactionStatusDesc	String	O	50	Description status transaction	Success
originalResponseCode	String	O	7	Response code	2005400
originalResponseMessage	String	O	150	Response description	Successful
sessionId	String	O	25	Transaction invoice ID	883737GHY8839
requestId	String	O	25	Transaction request ID	3763773
refundHistory	Array of Objects	O			

<b>Parameter</b>	<b>Data Type</b>	<b>Mandatory</b>	<b>Length</b>	<b>Description</b>	<b>Example</b>
refundNo	String	C	64	Transaction Identifier on Service Provider System	9619481694 1239812
partnerRefund No	String	M	64	ReferenceNo from PJP AIS for the refund.	23985091820 4981205970
refundAmount	Object	O			
value	String	M	16,2	Refund amount of the transaction. If it's IDR then value includes 2 decimal digits. e.g. IDR 10.000,- will be placed with 10000.00	12345678.00
currency	String	M	3	Currency	IDR
refundStatus	String	M	2	<b>00</b> = Success <b>03</b> = Pending <b>06</b> = Failed	00
refundDate	String	C	25	Format refund date : (ISO 8601) dd-MM-yyyy (Mandatory) HH:mm:ss  Must be filled upon successful	2020-12- 23T07:44:16 +07:00



<b>Parameter</b>	<b>Data Type</b>	<b>Mandatory</b>	<b>Length</b>	<b>Description</b>	<b>Example</b>
				refund transaction.	
reason	String	O	256	Refund reason.	Customer complain
transAmount	Object	O			
value	String	M	16,2	Transaction amount that will be paid using this payment method If it's IDR then value includes 2 decimal digits. e.g. IDR 10.000,- will be placed with 10000.00	12345678.00
currency	String	M	3	Currency (ISO 4217)	IDR
feeAmount	Object	O			
value	String	M	16,2	Fee amount that will be paid using this payment method If it's IDR then value includes 2 decimal digits.	12345678.00

<b>Parameter</b>	<b>Data Type</b>	<b>Mandatory</b>	<b>Length</b>	<b>Description</b>	<b>Example</b>
				e.g. IDR 10.000,- will be placed with 10000.00	
currency	String	M	3	Currency (ISO 4217)	IDR
paidTime	String	C	25	Transaction date : ISO 8601 YYYY-MM-DDThh:mm:ss.  Must be filled upon successful original transaction	2020-12-21T14:56:11+07:00
additionalInfo	Object	O	N/A	Additional information for custom use that are not provided by SNAP	{"deviceId": "12345679237", "channel": "mobilephone"}

### Contoh Request

```

POST .../v1.0/debit/status HTTP/1.2
Content-type: application/json
Authorization: Bearer
gp9HjjEj813Y9JGoqwOeOPWbnt4CUpvIJbU1mMU4a11MNDZ7Sg5u9a"
Authorization-Customer: Bearer
fa8sjjEj813Y9JGoqwOeOPWbnt4CUpvIJbU1mMU4a11MNDZ7Sg5u9a"
X-TIMESTAMP: 2020-12-23T07:44:11+07:00
X-SIGNATURE:
85be817c55b2c135157c7e89f52499bf0c25ad6eebe04a986e8c862561b19a5
ORIGIN: www.hostname.com
X-PARTNER-ID: 82150823919040624621823174737537
X-EXTERNAL-ID: 41807553358950093184162180797837
X-IP-ADDRESS: 172.24.281.24

```

X-DEVICE-ID: 09864ADCASA  
X-LATITUDE: -6.1617169  
X-LONGITUDE: 106.6643946  
CHANNEL-ID: 95221

```
{
  "originalPartnerReferenceNo": "202010290000000000000001",
  "originalReferenceNo": "202010297777000000000009",
  "originalExternalId": "30443786930722726463097920912",
  "serviceCode": "54",
  "transactionDate": "2020-12-21T14:56:11+07:00",
  "amount": {
    "value": "12345678.00",
    "currency": "IDR"
  },
  "merchantId": "23489182303312",
  "subMerchantId": "23489182303312",
  "externalStoreId": "183908924912387",
  "additionalInfo": {
    "deviceId": "12345679237",
    "channel": "mobilephone"
  }
}
```

## Contoh Response

Content-type: application/json  
X-TIMESTAMP: 2020-12-23T07:44:16+07:00

```
{
  "responseCode": "2005500",
  "responseMessage": "Successful",
  "originalPartnerReferenceNo": "202010290000000000000001",
  "originalReferenceNo": "202010297777000000000009",
  "approvalCode": "201039000200",
  "originalExternalId": "30443786930722726463097920912",
  "serviceCode": "54",
  "latestTransactionStatus": "00",
  "transactionStatusDesc": "Success",
  "originalResponseCode": "2005400",
  "originalResponseMessage": "Successful",
  "sessionId": "883737GHY8839",
  "requestId": "3763773",
  "refundHistory": [
    {
      "refundNo": "96194816941239812",
      "partnerReferenceNo": "239850918204981205970",
      "refundAmount": {
        "value": "12345678.00",

```

```

        "currency": "IDR"
    },
    "refundStatus": "00",
    "refundDate": "2020-12-23T07:44:16+07:00",
    "reason": "Customer Complain"
},
{
    "refundNo": "96194123981251341",
    "partnerReferenceNo": "2398509123131981205970",
    "refundAmount": {
        "value": "112345678.00",
        "currency": "IDR"
    },
    "refundStatus": "00",
    "refundDate": "2020-12-23T07:54:16+07:00",
    "reason": "Customer Complain"
}
],
"transAmount": {
    "value": "112345678.00",
    "currency": "IDR"
},
"feeAmount": {
    "value": "112345678.00",
    "currency": "IDR"
},
"paidTime": "2020-12-21T14:56:11+07:00",
"additionalInfo": {
    "deviceId": "12345679237",
    "channel": "mobilephone"
}
}

```

### c. Payment Notify

#### Informasi Umum

<b>Service Code</b>	56
<b>Name</b>	API Direct Debit Payment Notification
<b>Version</b>	1.0
<b>HTTP Method</b>	POST
<b>Path</b>	.../{version}/debit/notify

#### Request Body

<i>Parameter</i>	<i>Data Type</i>	<i>Mandatory</i>	<i>Length</i>	<i>Description</i>	<i>Example</i>
originalPartnerReferenceNo	String	O	64	Original transaction identifier on service consumer system	20201029000000000001
originalReferenceNo	String	M	64	Original transaction identifier on service provider system	2020102977770000000009
originalExternalId	String	O	32	Original Customer Reference Number	30443786930722726463280097920912
merchantId	String	O	64	Merchant identifier that is unique per each merchant	23489182303312
subMerchantId	String	O	32	Sub merchant ID	23489182303312
amount	Object	O			
value	String	M	16,2	Net amount of the transaction.	10000.00

<b>Parameter</b>	<b>Data Type</b>	<b>Mandatory</b>	<b>Length</b>	<b>Description</b>	<b>Example</b>
				If it's IDR then value includes 2 decimal digits. e.g. IDR 10.000,- will be placed with 10000.00	
currency	String	M	3	Currency (ISO 4217)	IDR
latestTransactionStatus	String	M	2	<b>00</b> = Success <b>01</b> = Initiated <b>02</b> = Paying <b>03</b> = Pending <b>04</b> = Refunded <b>05</b> = Canceled <b>06</b> = Failed <b>07</b> = Not found	00
transactionStatusDesc	String	O	50	Description status transaction	success
createdTime	String	O	25	Transaction created time.	2020-12-21T17:07:18+07:00
finishedTime	String	O	25	Transaction finished time.	2020-12-21T17:07:20+07:00
externalStoreId	String	O	64	External Store ID	91863213913112
additionalInfo	Object	O	N/A	Additional information for custom use that	{ "deviceId": "12345679237", "channel": "mobilephone" }

<b>Parameter</b>	<b>Data Type</b>	<b>Mandatory</b>	<b>Length</b>	<b>Description</b>	<b>Example</b>
				are not provided by SNAP	

### Response Body

<b>Parameter</b>	<b>Data Type</b>	<b>Mandatory</b>	<b>Length</b>	<b>Description</b>	<b>Example</b>
responseCode	String	M	7	Response code	2005600
approvalCode	String	O	20	Approval Code	201039000200
responseMessage	String	M	150	Response description	Successful

### Contoh Request

```

POST .../v1.0/debit/notify HTTP/1.2
Content-type: application/json
Authorization: Bearer
gp9HjjEj813Y9JGoqwOeOPWbnt4CUpvIJbU1mMU4a11MNDZ7Sg5u9a"
Authorization-Customer: Bearer
fa8sjjEj813Y9JGoqwOeOPWbnt4CUpvIJbU1mMU4a11MNDZ7Sg5u9a"
X-TIMESTAMP: 2020-12-23T07:44:11+07:00
X-SIGNATURE:
85be817c55b2c135157c7e89f52499bf0c25ad6eebe04a986e8c862561b19a5
ORIGIN: www.hostname.com
X-PARTNER-ID: 82150823919040624621823174737537
X-EXTERNAL-ID: 41807553358950093184162180797837
X-IP-ADDRESS: 172.24.281.24
X-DEVICE-ID: 09864ADCASA
X-LATITUDE: -6.1617169
X-LONGITUDE: 106.6643946
CHANNEL-ID: 95221

{
  "originalPartnerReferenceNo": "202010290000000000000001",
  "originalReferenceNo": "202010297777000000000009",
  "originalExternalId": "30443786930722726463097920912",
  "merchantId": "23489182303312",
  "subMerchantId": "23489182303312",

```

```
"amount":{
  "value":"10000.00",
  "currency":"IDR"
},
"latestTransactionStatus":"00",
"transactionStatusDesc":"success",
"createdTime":"2020-12-21T17:07:18+07:00",
"finishedTime":"2020-12-21T17:07:20+07:00",
"externalStoreId":"91863213913112",
"additionalInfo":{
  "deviceId":"12345679237",
  "channel":"mobilephone"
}
}
```

### **Contoh Response**

```
Content-type: application/json
X-TIMESTAMP: 2020-12-23T07:44:16+07:00
```

```
{
  "responseCode": "2005600",
  "approvalCode": "201039000200",
  "responseMessage": "Successful"
}
```



#### d. Cancel Payment

##### Informasi Umum

<b>Service Code</b>	57
<b>Name</b>	API Direct Debit Payment Cancel
<b>Version</b>	1.0
<b>HTTP Method</b>	POST
<b>Path</b>	.../{version}/debit/cancel

##### Request Body

<i>Parameter</i>	<i>Data Type</i>	<i>Mandatory</i>	<i>Length</i>	<i>Description</i>	<i>Example</i>
originalPartnerReferenceNo	String	M	64	Transaction identifier on service consumer system	20201029000000000001
originalReferenceNo	String	O	64	Original transaction identifier on service provider system	2020102977770000000009
approvalCode	String	O	20	Approval Code	201039000200
originalExternalId	String	O	32	Original External-ID on header message	30443786930722726463280097920912
merchantId	String	O	64	Merchant identifier that is unique per each merchant	23489182303312
subMerchantId	String	O	32	Sub merchant ID	23489182303312

<b>Parameter</b>	<b>Data Type</b>	<b>Mandatory</b>	<b>Length</b>	<b>Description</b>	<b>Example</b>
reason	String	O	256	Cancellation reason.	Network timeout
externalStoreId	String	O	64	External Store ID	124928924949487
amount	Object	O			
value	String	M	16,2	Transaction Amount	10000.00
currency	String	M	3	Currency (ISO 4217)	IDR
additionalInfo	Object	O	N/A	Additional information for custom use that are not provided by SNAP	{"deviceId": "12345679237", "channel": "mobilephone"}

### Response Body

<b>Parameter</b>	<b>Data Type</b>	<b>Mandatory</b>	<b>Length</b>	<b>Description</b>	<b>Example</b>
responseCode	String	M	7	Response code	2005700
responseMessage	String	M	150	Response description	Successful
originalPartnerReferenceNo	String	O	64	Original transaction identifier on service consumer system	20201029000000000001
originalReferenceNo	String	C	64	Original transaction identifier on	2020102977770000000009

<b>Parameter</b>	<b>Data Type</b>	<b>Mandatory</b>	<b>Length</b>	<b>Description</b>	<b>Example</b>
				service provider system	
originalExternalId	String	O	32	Original External-ID on header message	3044378693 0722726463 2800979209 12
cancelTime	String	C	25	Cancel transaction time.  Format cancel time: (ISO 8601) YYYY-MM-DDThh:mm:ss  Must be filled upon successful cancel transaction	2020-12-21T17:07:25+07:00
transactionDate	String	O	25	Transaction date  Format transaction date time: (ISO 8601) YYYY-MM-DDThh:mm:ss	2020-12-21T17:55:11+07:00
additionalInfo	Object	O	N/A	Additional information for custom use that are not provided by SNAP	{"deviceId": "12345679237", "channel": "mobilephone"}

## Contoh Request

```
POST .../v1.0/debit/cancel HTTP/1.2
Content-type: application/json
Authorization: Bearer
gp9HjjEj813Y9JGoqwOeOPWbnt4CUpvIJbU1mMU4a11MNDZ7Sg5u9a"
Authorization-Customer: Bearer
fa8sjjEj813Y9JGoqwOeOPWbnt4CUpvIJbU1mMU4a11MNDZ7Sg5u9a"
X-TIMESTAMP: 2020-12-23T07:44:11+07:00
X-SIGNATURE:
85be817c55b2c135157c7e89f52499bf0c25ad6eeeb04a986e8c862561b19a5
ORIGIN: www.hostname.com
X-PARTNER-ID: 82150823919040624621823174737537
X-EXTERNAL-ID: 41807553358950093184162180797837
X-IP-ADDRESS: 172.24.281.24
X-DEVICE-ID: 09864ADCASA
X-LATITUDE: -6.1617169
X-LONGITUDE: 106.6643946
CHANNEL-ID: 95221
```

```
{
  "originalPartnerReferenceNo": "202010290000000000000001",
  "originalReferenceNo": "202010297777000000000009",
  "approvalCode": "201039000200",
  "originalExternalId": "30443786930722726463097920912",
  "merchantId": "23489182303312",
  "subMerchantId": "23489182303312",
  "reason": "Network timeout",
  "externalStoreId": "124928924949487",
  "amount": {
    "value": "10000.00",
    "currency": "IDR"
  },
  "additionalInfo": {
    "deviceId": "12345679237",
    "channel": "mobilephone"
  }
}
```

## Contoh Response

```
Content-type: application/json
X-TIMESTAMP: 2020-12-23T07:44:16+07:00
```

```
{
  "responseCode": "2005700",
  "responseMessage": "Successful",
  "originalPartnerReferenceNo": "202010290000000000000001",
  "originalReferenceNo": "202010297777000000000009",
  "originalExternalId": "30443786930722726463097920912",
```

```
"cancelTime":"2020-12-21T17:07:25+07:00",  
"transactionDate":"2020-12-21T17:55:11+07:00",  
"additionalInfo":{  
  "deviceId":"12345679237",  
  "channel":"mobilephone"  
}  
}
```

## e. Refund Payment

### Informasi Umum

<b>Service Code</b>	58
<b>Name</b>	API Direct Debit Payment Refund
<b>Version</b>	1.0
<b>HTTP Method</b>	POST
<b>Path</b>	.../{version}/debit/refund

### Request Body

<b>Parameter</b>	<b>Data Type</b>	<b>Mandatory</b>	<b>Length</b>	<b>Description</b>	<b>Example</b>
merchantId	String	O	64	Merchant identifier that is unique per each merchant	0000710001 0926
subMerchantId	String	O	32	Sub merchant ID	3109289249 49487
originalPartnerReferenceNo	String	M	64	Original transaction identifier on service consumer system	2020102900 0000000000 01
originalReferenceNo	String	O	64	Original transaction identifier on service provider system	2020102977 7700000000 09
originalExternalId	String	O	32	Original Customer Reference Number	10052019

<b>Parameter</b>	<b>Data Type</b>	<b>Mandatory</b>	<b>Length</b>	<b>Description</b>	<b>Example</b>
partnerRefundNo	String	M	64	ReferenceNumber from PJP AIS for the refund.	23985091820 4981205970
refundAmount	Object	O			
value	String	M	16,2	Refund amount of the transaction. If it's IDR then value includes 2 decimal digits. e.g. IDR 10.000,- will be placed with 10000.00	10000.00
currency	String	M	3	Currency (ISO 4217)	IDR
externalStoreId	String	O	64	External Store IDE	1249289249 49487
reason	String	O	256	Refund reason.	Customer complain
additionalInfo	Object	O	N/A	Additional information for custom use that are not provided by SNAP	

### Response Body

<b>Parameter</b>	<b>Data Type</b>	<b>Mandatory</b>	<b>Length</b>	<b>Description</b>	<b>Example</b>
responseCode	String	M	7	Response code	2005800

<b>Parameter</b>	<b>Data Type</b>	<b>Mandatory</b>	<b>Length</b>	<b>Description</b>	<b>Example</b>
responseMessage	String	M	150	Response description	Successful
originalPartnerReferenceNo	String	O	64	Original transaction identifier on service consumer system	2020102900 0000000000 01
originalReferenceNo	String	C	64	Original transaction identifier on service provider system.  Must be filled upon successful refund transaction	2020102977 7700000000 09
originalExternalId	String	O	32	Original Customer Reference Number	10052019
partnerTrxId	String	O	32	Partner Transaction ID	LA001
refundNo	String	M	64	Refund Number	REF993883
partnerRefundNo	String	M	64	ReferenceNumber from PJP AIS for the refund.	23985091820 4981205970
refundAmount	Object	O			
value	String	M	16,2	Refund amount of the transaction.	10000.00



<b>Parameter</b>	<b>Data Type</b>	<b>Mandatory</b>	<b>Length</b>	<b>Description</b>	<b>Example</b>
				If it's IDR then value includes 2 decimal digits. e.g. IDR 10.000,- will be placed with 10000.00	
currency	String	M	3	Currency (ISO 4217)	IDR
refundTime	String	M	25	Refund time.  Format refund time: (ISO 8601)  YYYY-MM-DDThh:mm:ss	2020-12-21T17:21:41+07:00
additionalInfo	Object	O	N/A	Additional information for custom use that are not provided by SNAP	

### Contoh Request

```

POST .../v1.0/debit/refund HTTP/1.2
Content-type: application/json
Authorization: Bearer
gp9HjjEj813Y9JGoqwOeOPWbnt4CUpvIJbU1mMU4a11MNDZ7Sg5u9a"
Authorization-Customer: Bearer
fa8sjjEj813Y9JGoqwOeOPWbnt4CUpvIJbU1mMU4a11MNDZ7Sg5u9a"
X-TIMESTAMP: 2020-12-23T07:44:11+07:00
X-SIGNATURE:
85be817c55b2c135157c7e89f52499bf0c25ad6eebe04a986e8c862561b19a5

```

ORIGIN: www.hostname.com  
X-PARTNER-ID: 82150823919040624621823174737537  
X-EXTERNAL-ID: 41807553358950093184162180797837  
X-IP-ADDRESS: 172.24.281.24  
X-DEVICE-ID: 09864ADCASA  
X-LATITUDE: -6.1617169  
X-LONGITUDE: 106.6643946  
CHANNEL-ID: 95221

```
{
  "merchantId":"00007100010926",
  "subMerchantId":"310928924949487",
  "originalPartnerReferenceNo":"202010290000000000000001",
  "originalReferenceNo":"20201029777700000000009",
  "originalExternalId":"10052019",
  "partnerRefundNo":"239850918204981205970",
  "refundAmount":{
    "value":"10000.00",
    "currency":"IDR"
  },
  "externalStoreId":"124928924949487",
  "reason":"Customer complain",
  "additionalInfo":null
}
```

### Contoh Response

Content-type: application/json  
X-TIMESTAMP: 2020-12-23T07:44:16+07:00

```
{
  "responseCode":"2005800",
  "responseMessage":"Successful",
  "originalPartnerReferenceNo":"202010290000000000000001",
  "originalReferenceNo":"20201029777700000000009",
  "originalExternalId":"10052019",
  "partnerTrxId":"LA001",
  "refundNo":"REF993883",
  "partnerRefundNo":"239850918204981205970",
  "refundAmount":{
    "value":"10000.00",
    "currency":"IDR"
  },
  "refundTime":"2020-12-21T17:21:41+07:00",
  "additionalInfo":null
}
```

## 5.2.2. API QR CPM

### Sequence Diagram

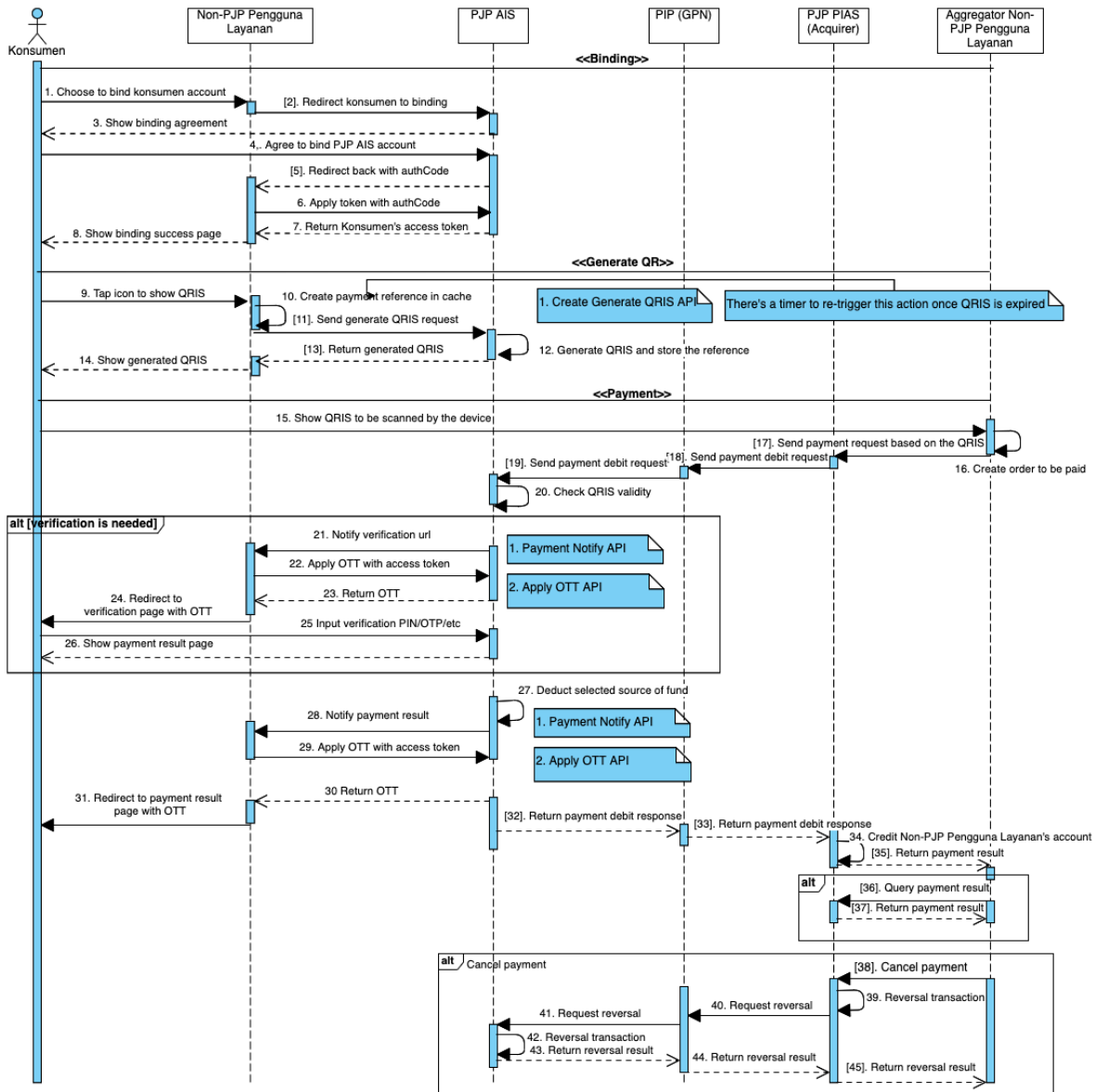

Sequence Diagram API QR CPM

#### a. Generate QR

#### Informasi Umum

<b>Service Code</b>	59
<b>Name</b>	API Generate QR CPM
<b>Version</b>	1.0
<b>HTTP Method</b>	POST
<b>Path</b>	.../{version}/qr/qr-cpm-generate

## Request Body

<b>Parameter</b>	<b>Data Type</b>	<b>Mandatory</b>	<b>Length</b>	<b>Description</b>	<b>Example</b>
partnerReferenceNo	String	O	64	Transaction identifier on service consumer system	2020102900 0000000000 01
userAccessToken	String	O	64	User Access Token	xxxxxxxx
merchantId	String	O	64	Merchant identifier that is unique per each merchant	0000710001 0926
subMerchantId	String	O	32	Sub merchant ID	3109289249 49487
partnerTrxDate	String	M	64	Partner transaction Date  Format partnet trx date: (ISO 8601)  YYYY-MM-DDThh:mm:ss	2020-12- 23T07:50:11 +07:00
additionalInfo	Object	O	N/A	Additional information for custom use that are not provided by SNAP	{"deviceId": "12345679237", "channel": "mobilephone"}

## Response Body

<b>Parameter</b>	<b>Data Type</b>	<b>Mandatory</b>	<b>Length</b>	<b>Description</b>	<b>Example</b>
responseCode	String	M	7	Response code	2005900
responseMessage	String	M	150	Response description	Successful
referenceNo	String	O	64	Transaction identifier on service provider system.	2020102977 7700000000 09
partnerReferenceNo	String	O	64	Transaction identifier on service consumer system	2020102900 0000000000 01
qrContent	String	O	512	QR String CPM	hduvY...
qrUrl	String	O	255	URL to show QR in web	PL0001
expiryTime	String	O	25	Expiry Time  Format expiry time: (ISO 8601)  YYYY-MM-DDThh:mm:ss	2020-12- 21T17:21:41 +07:00
additionalInfo	Object	O	N/A	Additional information for custom use that are not provided by SNAP	{"deviceId": "12345679237", "channel": "mobilephone"}

## Contoh Request

POST .../v1.0/qr/qr-cpm-generate HTTP/1.2

Content-type: application/json  
Authorization: Bearer  
gp9HjjEj813Y9JGoqwOeOPWbnt4CUpvIJbU1mMU4a11MNDZ7Sg5u9a"  
Authorization-Customer: Bearer  
fa8sjjEj813Y9JGoqwOeOPWbnt4CUpvIJbU1mMU4a11MNDZ7Sg5u9a"  
X-TIMESTAMP: 2020-12-23T07:50:11+07:00  
X-SIGNATURE:  
85be817c55b2c135157c7e89f52499bf0c25ad6eebe04a986e8c862561b19a5  
ORIGIN: www.hostname.com  
X-PARTNER-ID: 82150823919040624621823174737537  
X-EXTERNAL-ID: 41807553358950093184162180797837  
X-IP-ADDRESS: 172.24.281.24  
X-DEVICE-ID: 09864ADCASA  
X-LATITUDE: -6.108841  
X-LONGITUDE: 106.7782137  
CHANNEL-ID: 95221

```
{
  "partnerReferenceNo": "2020102900000000000001",
  "userAccessToken": "xxxxxx",
  "merchantId": "00007100010926",
  "subMerchantId": "310928924949487",
  "partnerTrxDate": "2020-12-23T07:50:11+07:00",
  "additionalInfo": {
    "deviceId": "12345679237",
    "channel": "mobilephone"
  }
}
```

### Contoh Response

Content-type: application/json  
X-TIMESTAMP: 2020-12-23T07:50:19+07:00

```
{
  "responseCode": "2005900",
  "responseMessage": "Successful",
  "referenceNo": "20201029777700000000009",
  "partnerReferenceNo": "2020102900000000000001",
  "qrContent": "hduvY...",
  "qrUrl": "PL0001",
  "expiryTime": "2020-12-21T17:21:41+07:00",
  "additionalInfo": {
    "deviceId": "12345679237",
    "channel": "mobilephone"
  }
}
```

## b. CPM Payment

### Informasi Umum

<b>Service Code</b>	60
<b>Name</b>	API CPM Payment
<b>Version</b>	1.0
<b>HTTP Method</b>	POST
<b>Path</b>	.../{version}/qr/qr-cpm-payment

### Request Body

<i>Parameter</i>	<i>Data Type</i>	<i>Mandatory</i>	<i>Length</i>	<i>Description</i>	<i>Example</i>
partnerReferenceNo	String	M	64	Transaction identifier on service consumer system	2020102900 0000000000 01
qrContent	String	M	512	QR String CPM	hduvY...
amount	Object	O			
value	String	M	16,2	Transaction Amount	12345678.00
currency	String	M	3	Currency (ISO 4217)	IDR
feeAmount	Object	O			
value	String	M	16,2	Transaction fee. If it's IDR then value includes 2 decimal digits. e.g. IDR 10.000,- will be placed with 10000.00	12345678.00

<b>Parameter</b>	<b>Data Type</b>	<b>Mandatory</b>	<b>Length</b>	<b>Description</b>	<b>Example</b>
currency	String	M	3	Currency (ISO 4217)	IDR
merchantId	String	M	64	Merchant identifier that is unique per each merchant	00007100010926
subMerchantId	String	O	32	Sub merchant ID	310928924949487
title	String	O	256	Brief description	example
expiryTime	String	O	25	Expiry time. Format expiry time: (ISO 8601) YYYY-MM-DDThh:mm:ss	2020-12-21T17:21:41+07:00
items	Object	O		For items	
externalStoreId	String	O	64	Unique shop id in merchant side.	abcd
merchantName	String	O	64	Merchant name	Merchant01
merchantLocation	String	O	64	Merchant location	Jakarta Indonesia
acquirerName	String	O	64	Acquire Name	LinkAja
terminalId	String	O	32	Terminal Id	6476378
scannerInfo	Object	O			
deviceId	String	O	64	The unique device id.	46252



<b>Parameter</b>	<b>Data Type</b>	<b>Mandatory</b>	<b>Length</b>	<b>Description</b>	<b>Example</b>
deviceVersion	String	O	128	The device firmware version, updatable	v.1.0
deviceModel	String	O	128	The device model, not updateable.	Scanner
deviceIp	String	O	64	The Public IP address when device sends out the request.	172.24.281.24
additionalInfo	Object	O	N/A	Additional information for custom use that are not provided by SNAP	{"deviceId": "12345679237", "channel": "mobilephone"}

### Response Body

<b>Parameter</b>	<b>Data Type</b>	<b>Mandatory</b>	<b>Length</b>	<b>Description</b>	<b>Example</b>
responseCode	String	M	7	Response code	2006000
responseMessage	String	M	150	Response description	Successful
referenceNo	String	C	64	Transaction identifier on service provider system.	2020102977 7700000000 09

<b>Parameter</b>	<b>Data Type</b>	<b>Mandatory</b>	<b>Length</b>	<b>Description</b>	<b>Example</b>
				Must be filled upon successful transaction	
partnerReferenceNo	String	O	64	Transaction identifier on service consumer system	2020102900 0000000000 01
transactionDate	String	O	25	Transaction date  Format transaction date: (ISO 8601)  YYYY-MM-DDThh:mm:ss	2020-12- 23T07:54:11 +07:00
additionalInfo	Object	O	N/A	Additional information for custom use that are not provided by SNAP	{"deviceId": "12345679237", "channel": "mobilephone"}

### Contoh Request

```

POST .../v1.0/qr/qr-cpm-payment HTTP/1.2
Content-type: application/json
Authorization: Bearer
gp9HjjEj813Y9JGoqwOeOPWbnt4CUpvIJbU1mMU4a11MNDZ7Sg5u9a"
Authorization-Customer: Bearer
fa8sjjEj813Y9JGoqwOeOPWbnt4CUpvIJbU1mMU4a11MNDZ7Sg5u9a"
X-TIMESTAMP: 2020-12-23T07:54:11+07:00
X-SIGNATURE:
85be817c55b2c135157c7e89f52499bf0c25ad6eebe04a986e8c862561b19a5
ORIGIN: www.hostname.com
X-PARTNER-ID: 82150823919040624621823174737537
X-EXTERNAL-ID: 41807553358950093184162180797837

```

X-IP-ADDRESS: 172.24.281.24  
X-DEVICE-ID: 09864ADCASA  
X-LATITUDE: -6.108841  
X-LONGITUDE: 106.7782137  
CHANNEL-ID: 95221

```
{
  "partnerReferenceNo": "2020102900000000000001",
  "qrContent": "hduvY...",
  "amount": {
    "value": "12345678.00",
    "currency": "IDR"
  },
  "feeAmount": {
    "value": "12345678.00",
    "currency": "IDR"
  },
  "merchantId": "00007100010926",
  "subMerchantId": "310928924949487",
  "title": "example",
  "expiryTime": "2020-12-21T17:21:41+07:00",
  "items": {
    "productId": "12345",
    "productName": "goods A",
    "qty": "6",
    "desc": "barang"
  },
  "externalStoreId": "abcd",
  "merchantName": "Merchant01",
  "merchantLocation": "Jakarta Indonesia",
  "acquirerName": "LinkAja",
  "terminalId": "6476378",
  "scannerInfo": {
    "deviceId": "46252",
    "deviceVersion": "v.1.0",
    "deviceModel": "Scanner",
    "deviceIp": "172.24.281.24"
  },
  "additionalInfo": {
    "deviceId": "12345679237",
    "channel": "mobilephone"
  }
}
```

### Contoh Response

Content-type: application/json  
X-TIMESTAMP: 2020-12-23T07:54:19+07:00

```
{
  "responseCode": "2006000",
  "responseMessage": "Successful",
  "referenceNo": "20201029777700000000009",
  "partnerReferenceNo": "2020102900000000000001",
  "transactionDate": "2020-12-23T07:54:11+07:00",
  "additionalInfo": {
    "deviceId": "12345679237",
    "channel": "mobilephone"
  }
}
```

### c. Query Payment

#### Informasi Umum

<b>Service Code</b>	61
<b>Name</b>	API Query Payment
<b>Version</b>	1.0
<b>HTTP Method</b>	POST
<b>Path</b>	.../{version}/qr/qr-cpm-query

#### Request Body

<b>Parameter</b>	<b>Data Type</b>	<b>Mandatory</b>	<b>Length</b>	<b>Description</b>	<b>Example</b>
originalReferenceNo	String	O	64	Original transaction identifier on service provider system.	2020102977 7700000000 09
originalPartnerReferenceNo	String	O	64	Original transaction identifier on service consumer system	2020102900 0000000000 01
originalExternalId	String	O	32	Original Customer Reference Number	10052019
merchantId	String	O	64	Merchant identifier that is unique per each merchant	0000710001 0926
subMerchantId	String	O	32	Sub merchant ID	3109289249 49487
externalStoreId	String	O	64	External Store ID	1249289249 49487

<b>Parameter</b>	<b>Data Type</b>	<b>Mandatory</b>	<b>Length</b>	<b>Description</b>	<b>Example</b>
additionalInfo	Object	O	N/A	Additional information for custom use that are not provided by SNAP	{ "deviceId": "12345679237", "channel": "mobilephone"}

### Response Body

<b>Parameter</b>	<b>Data Type</b>	<b>Mandatory</b>	<b>Length</b>	<b>Description</b>	<b>Example</b>
responseCode	String	M	7	Response code	2006100
responseMessage	String	M	150	Response description	Successful
originalReferenceNo	String	C	64	Original transaction identifier on service provider system	2020102977 7700000000 09
originalPartnerReferenceNo	String	O	64	Original transaction identifier on service consumer system.  Must be filled upon successful original transaction	2020102900 0000000000 01
originalExternalId	String	O	32	Original Customer	10052019

<b>Parameter</b>	<b>Data Type</b>	<b>Mandatory</b>	<b>Length</b>	<b>Description</b>	<b>Example</b>
				Reference Number	
title	string	O	256	Title query	example
latestTransactionStatus	String	M	2	<b>00</b> = Success <b>01</b> = Initiated <b>02</b> = Paying <b>03</b> = Pending <b>04</b> = Refunded <b>05</b> = Canceled <b>06</b> = Failed <b>07</b> = Not Found	00
transactionStatusDesc	String	O	50	Description status transaction	success
paidTime	String	M	25	Paid Time  Format paid time: (ISO-8601) YYYY-MM-DDThh:mm:ss	2020-12-23T08:04:11+07:00
additionalInfo	Object	O	N/A	Additional information for custom use that are not provided by SNAP	{"deviceId": "12345679237", "channel": "mobilephone"}

### Contoh Request

```

POST .../v1.0/qr/qr-cpm-query HTTP/1.2
Content-type: application/json
Authorization: Bearer
gp9HjjEj813Y9JGoqwOeOPWbnt4CUvpIJbU1mMU4a11MNDZ7Sg5u9a"

```

Authorization-Customer: Bearer  
fa8sjjEj813Y9JGoqwOeOPWbnt4CUpvIJbU1mMU4a11MNDZ7Sg5u9a"  
X-TIMESTAMP: 2020-12-23T08:04:11+07:00  
X-SIGNATURE:  
85be817c55b2c135157c7e89f52499bf0c25ad6eeeb04a986e8c862561b19a5  
ORIGIN: www.hostname.com  
X-PARTNER-ID: 82150823919040624621823174737537  
X-EXTERNAL-ID: 41807553358950093184162180797837  
X-IP-ADDRESS: 172.24.281.24  
X-DEVICE-ID: 09864ADCASA  
X-LATITUDE: -6.108841  
X-LONGITUDE: 106.7782137  
CHANNEL-ID: 95221

```
{  
  "originalReferenceNo":"2020102977770000000009",  
  "originalPartnerReferenceNo":"2020102900000000000001",  
  "originalExternalId":"10052019",  
  "merchantId":"00007100010926",  
  "subMerchantId":"310928924949487",  
  "externalStoreId":"124928924949487",  
  "additionalInfo":{  
    "deviceId":"12345679237",  
    "channel":"mobilephone"  
  }  
}
```

## Contoh Response

Content-type: application/json  
X-TIMESTAMP: 2020-12-23T08:04:18+07:00

```
{  
  "responseCode":"2006100",  
  "responseMessage":"Successful",  
  "originalReferenceNo":"2020102977770000000009",  
  "originalPartnerReferenceNo":"2020102900000000000001",  
  "originalExternalId":"10052019",  
  "title":"example",  
  "latestTransactionStatus":"00",  
  "transactionStatusDesc":"success",  
  "paidTime":"2020-12-23T08:04:11+07:00",  
  "additionalInfo":{  
    "deviceId":"12345679237",  
    "channel":"mobilephone"  
  }  
}
```



#### d. Cancel Payment

##### Informasi Umum

<b>Service Code</b>	62
<b>Name</b>	API Cancel Payment
<b>Version</b>	1.0
<b>HTTP Method</b>	POST
<b>Path</b>	.../{version}/qr/qr-cpm-cancel

##### Request Body

<i>Parameter</i>	<i>Data Type</i>	<i>Mandatory</i>	<i>Length</i>	<i>Description</i>	<i>Example</i>
originalPartnerReferenceNo	String	M	64	Original transaction identifier on service consumer system	20201029000000000001
originalReferenceNo	String	O	64	Original transaction identifier on service provider system	2020102977770000000009
originalExternalId	String	O	32	Original External-ID on header message	30443786930722726463280097920912
merchantId	String	O	64	Merchant identifier that is unique per each merchant	00007100010926
subMerchantId	String	O	32	Sub merchant ID	310928924949487
externalStoreId	String	O	64	External Store ID	124928924949487

<b>Parameter</b>	<b>Data Type</b>	<b>Mandatory</b>	<b>Length</b>	<b>Description</b>	<b>Example</b>
amount	Object	O			
value	String	M	16,2	Transaction Amount	10000.00
currency	String	M	3	Currency (ISO 4217)	IDR
reason	String	O	256	Cancellation reason	Cancel reason
additionalInfo	Object	O	N/A	Additional information for custom use that are not provided by SNAP	{ "deviceId": "12345679237", "channel": "mobilephone"}

### Response Body

<b>Parameter</b>	<b>Data Type</b>	<b>Mandatory</b>	<b>Length</b>	<b>Description</b>	<b>Example</b>
responseCode	String	M	7	Response code	2006200
responseMessage	String	M	150	Response description	Successful
originalPartnerReferenceNo	String	O	64	Original transaction identifier on service consumer system	2020102900 0000000000 01
originalReferenceNo	String	C	64	Original transaction identifier on service provider system.	2020102977 7700000000 09

<b>Parameter</b>	<b>Data Type</b>	<b>Mandatory</b>	<b>Length</b>	<b>Description</b>	<b>Example</b>
				Must be filled upon successful cancel transaction	
originalExternalId	String	O	32	Original External-ID on header message	3044378693 0722726463 2800979209 12
cancelTime	String	C	25	Cancel time  Format cancel time: (ISO 8601) YYYY-MM-DDThh:mm:ss  Must be filled upon successful cancel transaction	2020-12-21T17:07:25+07:00
transactionDate	String	O	25	Transaction date  Format transaction date: (ISO 8601) YYYY-MM-DDThh:mm:ss	2020-12-21T17:55:11+07:00
additionalInfo	Object	O	N/A	Additional information for custom use that are not provided	{"deviceId": "12345679237", "channel": "mobilephone"}

<b>Parameter</b>	<b>Data Type</b>	<b>Mandatory</b>	<b>Length</b>	<b>Description</b>	<b>Example</b>
				by SNAP	

### Contoh Request

```

POST .../v1.0/qr/qr-cpm-cancel HTTP/1.2
Content-type: application/json
Authorization: Bearer
gp9HjjEj813Y9JGoqwOeOPWbnt4CUpvIJbU1mMU4a11MNDZ7Sg5u9a"
Authorization-Customer: Bearer
fa8sjjEj813Y9JGoqwOeOPWbnt4CUpvIJbU1mMU4a11MNDZ7Sg5u9a"
X-TIMESTAMP: 2020-12-23T08:10:11+07:00
X-SIGNATURE:
85be817c55b2c135157c7e89f52499bf0c25ad6eeeb04a986e8c862561b19a5
ORIGIN: www.hostname.com
X-PARTNER-ID: 82150823919040624621823174737537
X-EXTERNAL-ID: 41807553358950093184162180797837
X-IP-ADDRESS: 172.24.281.24
X-DEVICE-ID: 09864ADCASA
X-LATITUDE: -6.108841
X-LONGITUDE: 106.7782137
CHANNEL-ID: 95221

{
  "originalPartnerReferenceNo": "2020102900000000000001",
  "originalReferenceNo": "2020102977770000000009",
  "originalExternalId": "30443786930722726463097920912",
  "merchantId": "00007100010926",
  "subMerchantId": "310928924949487",
  "externalStoreId": "124928924949487",
  "amount": {
    "value": "10000.00",
    "currency": "IDR"
  },
  "reason": "cancel reason",
  "additionalInfo": {
    "deviceId": "12345679237",
    "channel": "mobilephone"
  }
}

```

### Contoh Response

```

Content-type: application/json
X-TIMESTAMP: 2020-12-23T08:10:18+07:00

```

```
{
  "responseCode": "2006200",
  "responseMessage": "Successful",
  "originalPartnerReferenceNo": "2020102900000000000001",
  "originalReferenceNo": "2020102977770000000009",
  "originalExternalId": "30443786930722726463097920912",
  "cancelTime": "2020-12-21T17:07:25+07:00",
  "transactionDate": "2020-12-21T17:55:11+07:00",
  "additionalInfo": {
    "deviceId": "12345679237",
    "channel": "mobilephone"
  }
}
```

## e. Payment Notify

### Informasi Umum

<b>Service Code</b>	79
<b>Name</b>	API Payment Notification
<b>Version</b>	1.0
<b>HTTP Method</b>	POST
<b>Path</b>	.../{version}/qr/qr-cpm-notify

### Request Body

<i>Parameter</i>	<i>Data Type</i>	<i>Mandatory</i>	<i>Length</i>	<i>Description</i>	<i>Example</i>
originalPartnerReferenceNo	String	O	64	Original transaction identifier on service consumer system	20201029000000000001
originalReferenceNo	String	O	64	Original transaction identifier on service provider system	2020102977770000000009
merchantId	String	M	64	Merchant identifier that is unique per each merchant	00007100010926
subMerchantId	String	O	32	Sub merchant ID	310928924949487
externalStoreId	String	O	64	External Store ID	124928924949487
amount	Object	O			
value	String	M	16,2	Net amount of the transaction.	50000.00

<b>Parameter</b>	<b>Data Type</b>	<b>Mandatory</b>	<b>Length</b>	<b>Description</b>	<b>Example</b>
				If it's IDR then value includes 2 decimal digits. e.g. IDR 10.000,- will be placed with 10000.00	
currency	String	M	3	Currency (ISO 4217)	IDR
latestTransactionStatus	String	M	2	<b>00</b> = Success <b>01</b> = Initiated <b>02</b> = Paying <b>03</b> = Pending <b>04</b> = Refunded <b>05</b> = Canceled <b>06</b> = Failed <b>07</b> = Not found	00
transactionStatusDesc	String	O	50	Description status transaction	Success
customerNumber	String	O	64	Customer Account Number	6281388370001
accountType	String	O	25	Account type	tabungan
destinationNumber	String	O	25	Destination account number	8377388292
destinationAccountName	String	O	25	Destination account name	John doe

<b>Parameter</b>	<b>Data Type</b>	<b>Mandatory</b>	<b>Length</b>	<b>Description</b>	<b>Example</b>
sessionId	String	O	25	Session id	OUYEB77329 002HY
bankCode	String	O	8	Bank code	002
additionalInfo	Object	O	N/A	Additional information for custom use that are not provided by SNAP	{"deviceId": "12345679237", "channel": "mobilephone"}

### Response Body

<b>Parameter</b>	<b>Data Type</b>	<b>Mandatory</b>	<b>Length</b>	<b>Description</b>	<b>Example</b>
responseCode	String	M	7	Response code	2007900
responseMessage	String	M	150	Response description	Successful
additionalInfo	Object	O	N/A	Additional information for custom use that are not provided by SNAP	{"deviceId": "12345679237", "channel": "mobilephone"}

### Contoh Request

```
POST .../v1.0/qr/qr-cpm-notify HTTP/1.2
Content-type: application/json
Authorization: Bearer
gp9HjjEj813Y9JGoqwOeOPWbnt4CUpvIJbU1mMU4a11MNDZ7Sg5u9a"
Authorization-Customer: Bearer
fa8sjjEj813Y9JGoqwOeOPWbnt4CUpvIJbU1mMU4a11MNDZ7Sg5u9a"
X-TIMESTAMP: 2020-12-23T08:46:11+07:00
X-SIGNATURE:
85be817c55b2c135157c7e89f52499bf0c25ad6eebe04a986e8c862561b19a5
```



ORIGIN: www.hostname.com  
X-PARTNER-ID: 82150823919040624621823174737537  
X-EXTERNAL-ID: 41807553358950093184162180797837  
X-IP-ADDRESS: 172.24.281.24  
X-DEVICE-ID: 09864ADCASA  
X-LATITUDE: -6.108841  
X-LONGITUDE: 106.7782137  
CHANNEL-ID: 95221

```
{
  "originalPartnerReferenceNo": "202010290000000000000001",
  "originalReferenceNo": "20201029777700000000009",
  "merchantId": "00007100010926",
  "subMerchantId": "310928924949487",
  "externalStoreId": "124928924949487",
  "amount": {
    "value": "50000.00",
    "currency": "IDR"
  },
  "latestTransactionStatus": "00",
  "transactionStatusDesc": "success",
  "customerNumber": "6281388370001",
  "accountType": "tabungan",
  "destinationNumber": "8377388292",
  "destinationAccountName": "John Doe",
  "sessionId": "0UYEB77329002HY",
  "bankCode": "002",
  "additionalInfo": {
    "deviceId": "12345679237",
    "channel": "mobilephone"
  }
}
```

## Contoh Response

Content-type: application/json  
X-TIMESTAMP: 2020-12-23T08:46:16+07:00

```
{
  "responseCode": "2007900",
  "responseMessage": "Successful",
  "additionalInfo": {
    "deviceId": "12345679237",
    "channel": "mobilephone"
  }
}
```

## f. Refund Payment

### Informasi Umum

<b>Service Code</b>	80
<b>Name</b>	API Refund Payment
<b>Version</b>	1.0
<b>HTTP Method</b>	POST
<b>Path</b>	.../{version}/qr/qr-cpm-refund

### Request Body

<i>Parameter</i>	<i>Data Type</i>	<i>Mandatory</i>	<i>Length</i>	<i>Description</i>	<i>Example</i>
merchantId	String	O	64	Merchant identifier that is unique per each merchant	00007100010926
subMerchantId	String	O	32	Sub merchant ID	310928924949487
externalStoreId	String	O	64	External Store ID	124928924949487
originalPartnerReferenceNo	String	M	64	Original transaction identifier on service consumer system	20201029000000000001
originalReferenceNo	String	O	64	Original transaction identifier on service provider system	2020102977770000000009
originalExternalId	String	O	32	Original Customer Reference Number	10052019

<b>Parameter</b>	<b>Data Type</b>	<b>Mandatory</b>	<b>Length</b>	<b>Description</b>	<b>Example</b>
partnerRefund No	String	M	64	ReferenceNumber from PJP AIS for the refund.	23985091820 4981205970
refundAmount	Object	O			
value	String	M	16,2	Refund amount of the transaction. If it's IDR then value includes 2 decimal digits. e.g. IDR 10.000,- will be placed with 10000.00	10000.00
currency	String	M	3	Currency (ISO 4217)	IDR
reason	String	O	256	Refund reason.	Customer complain
additionalInfo	Object	O	N/A	Additional information for custom use that are not provided by SNAP	

## Response Body

<b>Parameter</b>	<b>Data Type</b>	<b>Mandatory</b>	<b>Length</b>	<b>Description</b>	<b>Example</b>
responseCode	String	M	7	Response code	2008000
responseMessage	String	M	150	Response description	Successful
originalPartnerReferenceNo	String	M	64	Original transaction identifier on service consumer system.	2020102900 0000000000 01
originalReferenceNo	String	O	64	Original transaction identifier on service provider system	2020102977 7700000000 09
originalExternalId	String	O	32	Original Customer Reference Number	10052019
refundNo	String	M	64	Reference Refund Number	REF993883
partnerRefundNo	String	O	64	ReferenceNumber from PJP AIS for the refund.	2398509182 0498120597 0
refundAmount	Object	O			
value	String	M	16,2	Refund amount of the transaction.	10000.00

<b>Parameter</b>	<b>Data Type</b>	<b>Mandatory</b>	<b>Length</b>	<b>Description</b>	<b>Example</b>
				If it's IDR then value includes 2 decimal digits. e.g. IDR 10.000,- will be placed with 10000.00	
currency	String	M	3	Currency (ISO 4217)	IDR
refundTime	String	M	25	Refund time. Format refund time: (ISO 8601) YYYY-MM-DDThh:mm:ss	2020-12-21T17:21:41+07:00
additionalInfo	Object	O	N/A	Additional information for custom use that are not provided by SNAP	

### Contoh Request

```

POST .../v1.0/qr/qr-cpm-refund HTTP/1.2
Content-type: application/json
Authorization: Bearer
gp9HjjEj813Y9JGoqwOeOPWbnt4CUpvIJbU1mMU4a11MNDZ7Sg5u9a"
Authorization-Customer: Bearer
fa8sjjEj813Y9JGoqwOeOPWbnt4CUpvIJbU1mMU4a11MNDZ7Sg5u9a"
X-TIMESTAMP: 2020-12-23T08:10:11+07:00
X-SIGNATURE:
85be817c55b2c135157c7e89f52499bf0c25ad6eebe04a986e8c862561b19a5
ORIGIN: www.hostname.com
X-PARTNER-ID: 82150823919040624621823174737537
X-EXTERNAL-ID: 41807553358950093184162180797837

```

X-IP-ADDRESS: 172.24.281.24  
X-DEVICE-ID: 09864ADCASA  
X-LATITUDE: -6.108841  
X-LONGITUDE: 106.7782137  
CHANNEL-ID: 95221

```
{
  "merchantId":"00007100010926",
  "subMerchantId":"310928924949487",
  "externalStoreId":"124928924949487",
  "originalPartnerReferenceNo":"202010290000000000000001",
  "originalReferenceNo":"20201029777700000000009",
  "originalExternalId":"10052019",
  "partnerRefundNo":"239850918204981205970",
  "refundAmount":{
    "value":"10000.00",
    "currency":"IDR"
  },
  "reason":"Customer complain",
  "additionalInfo":null
}
```

## Contoh Response

Content-type: application/json  
X-TIMESTAMP: 2020-12-23T08:10:18+07:00

```
{
  "responseCode":"2008000",
  "responseMessage":"Successful",
  "originalPartnerReferenceNo":"202010290000000000000001",
  "originalReferenceNo":"20201029777700000000009",
  "originalExternalId":"10052019",
  "refundNo":"REF993883",
  "partnerRefundNo":"239850918204981205970",
  "refundAmount":{
    "value":"10000.00",
    "currency":"IDR"
  },
  "refundTime":"2020-12-21T17:21:41+07:00",
  "additionalInfo":null
}
```

### 5.2.3. API Auth Payment

#### Sequence Diagram

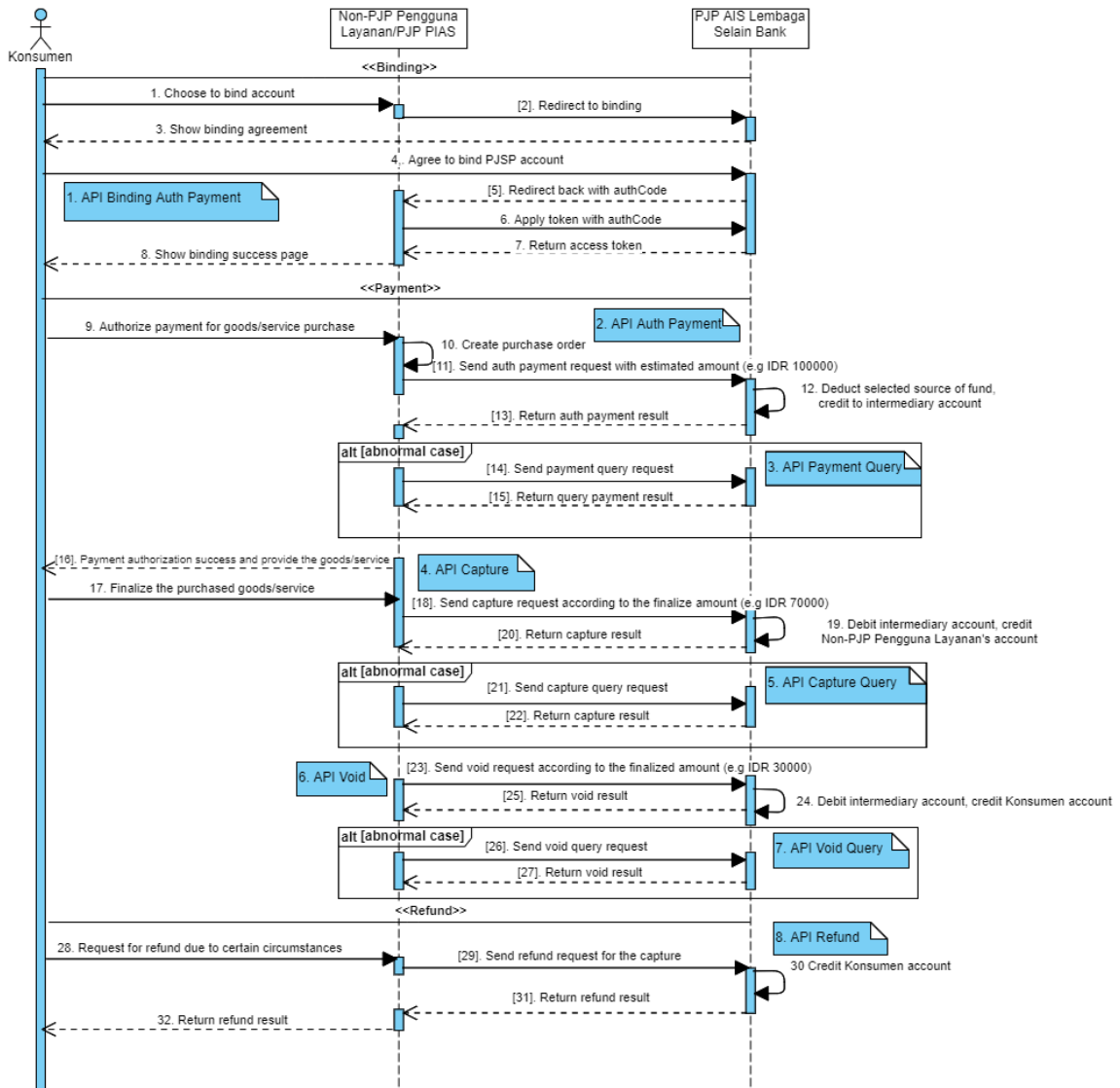

Sequence Diagram API Auth Payment

## a. API Auth Payment

### Informasi Umum

<b>Service Code</b>	63
<b>Name</b>	API Auth Payment
<b>Version</b>	1.0
<b>HTTP Method</b>	POST
<b>Path</b>	.../{version}/auth/payment

### Request Body

<i>Parameter</i>	<i>Data Type</i>	<i>Mandatory</i>	<i>Length</i>	<i>Description</i>	<i>Example</i>
partnerReferenceNo	String	M	64	Transaction identifier on service consumer system	2020102900 0000000000 01
merchantId	String	M	64	Merchant identifier that is unique per each merchant	0000710001 0926
subMerchantId	String	O	32	Sub merchant ID	3109289249 49487
amount	Object	O			
value	String	M	16,2	Net amount of the transaction. If it's IDR then value includes 2 decimal digits. e.g. IDR 10.000,- will be	12345678.00



<i>Parameter</i>	<i>Data Type</i>	<i>Mandatory</i>	<i>Length</i>	<i>Description</i>	<i>Example</i>
				placed with 10000.00	
currency	String	M	3	Currency (ISO 4217)	IDR
feeType	String	O	25	To whom the fee will be charged  <b>OUR</b> = Fee is charged to the sender (default) <b>BEN</b> = Fee is charged to the recipient <b>SHA   1000</b> = Fee is shared between sender and recipient, with sender is charged Rp 1.000,00 and the recipient will be charged the rest	BEN
mcc	String	O	32	Merchant's category.	5743
productCode	String	O	64	Product code to identify which product used for this	2938409182 03

<b>Parameter</b>	<b>Data Type</b>	<b>Mandatory</b>	<b>Length</b>	<b>Description</b>	<b>Example</b>
				particular payment.	
title	String	M	256	Order title.	Ikan bakar bumbu kuning
items	List<Goods>	O	N/A	Purchased goods/service information.	{ "goodsId": "908132", "price": {"currency": "360", "value": "10000"}, "category": "food", "unit": "ekor", "quantity": "2" }
additionalInfo	Object	O		Additional information for custom use that are not provided by SNAP	{"deviceId": "12345679237", "channel": "mobilephone"}

### Response Body

<b>Parameter</b>	<b>Data Type</b>	<b>Mandatory</b>	<b>Length</b>	<b>Description</b>	<b>Example</b>
responseCode	String	M	7	Response code	2006300
responseMessage	String	M	150	Response description	Successful

<b>Parameter</b>	<b>Data Type</b>	<b>Mandatory</b>	<b>Length</b>	<b>Description</b>	<b>Example</b>
referenceNo	String	C	64	Transaction identifier on service provider system.  Must be filled upon successful transaction	2020102977 7700000000 09
partnerReferenceNo	String	O	64	Transaction identifier on service consumer system	2020102900 0000000000 01
amount	Object	O			
value	String	M	16,2	Net amount of the transaction. If it's IDR then value includes 2 decimal digits. e.g. IDR 10.000,- will be placed with 10000.00	10000.00
currency	String	M	3	Currency (ISO 4217)	IDR
paidTime	String	M	25	Transaction paid time. ISO 8601 YYYY-MM-DDThh:mm:ss	2009-07-03T12:08:56+07:00

<b>Parameter</b>	<b>Data Type</b>	<b>Mandatory</b>	<b>Length</b>	<b>Description</b>	<b>Example</b>
additionalInfo	Object	O	N/A	Additional information for custom use that are not provided by SNAP	{"deviceId": "12345679237", "channel": "mobilephone"}

### Contoh Request

```
POST .../v1.0/auth/payment HTTP/1.2
Content-type: application/json
Authorization: Bearer
gp9HjjEj813Y9JGoqwOeOPWbnt4CUpvIJbU1mMU4a11MNDZ7Sg5u9a"
Authorization-Customer: Bearer
fa8sjjEj813Y9JGoqwOeOPWbnt4CUpvIJbU1mMU4a11MNDZ7Sg5u9a"
X-TIMESTAMP: 2020-12-23T08:58:11+07:00
X-SIGNATURE:
85be817c55b2c135157c7e89f52499bf0c25ad6eeeb04a986e8c862561b19a5
ORIGIN: www.hostname.com
X-PARTNER-ID: 82150823919040624621823174737537
X-EXTERNAL-ID: 41807553358950093184162180797837
X-IP-ADDRESS: 172.24.281.24
X-DEVICE-ID: 09864ADCASA
X-LATITUDE: -6.108841
X-LONGITUDE: 106.7782137
CHANNEL-ID: 95221
```

```
{
  "partnerReferenceNo": "202010290000000000000001",
  "merchantId": "00007100010926",
  "subMerchantId": "310928924949487",
  "amount": {
    "value": "12345678.00",
    "currency": "IDR"
  },
  "feeType": "BEN",
  "mcc": "5743",
  "productCode": "293840918203",
  "title": "Ikan bakar bumbu kuning",
  "items": {
    "goodsId": "908132",
    "price": {
      "value": "10000.00",
```

```
        "currency": "IDR"
      },
      "category": "food",
      "unit": "ekor",
      "quantity": "2"
    },
    "additionalInfo": {
      "deviceId": "12345679237",
      "channel": "mobilephone"
    }
  }
}
```

### Contoh Response

Content-type: application/json  
X-TIMESTAMP: 2020-12-23T08:58:19+07:00

```
{
  "responseCode": "2006300",
  "responseMessage": "Successful",
  "referenceNo": "20201029777700000000009",
  "partnerReferenceNo": "20201029000000000000001",
  "amount": {
    "value": "10000.00",
    "currency": "IDR"
  },
  "paidTime": "2009-07-03T12:08:56+07:00",
  "additionalInfo": {
    "deviceId": "12345679237",
    "channel": "mobilephone"
  }
}
```

## b. API Payment Query

### Informasi Umum

<b>Service Code</b>	64
<b>Name</b>	API Payment Query
<b>Version</b>	1.0
<b>HTTP Method</b>	POST
<b>Path</b>	.../{version}/auth/query

### Request Body

<i>Parameter</i>	<i>Data Type</i>	<i>Mandatory</i>	<i>Length</i>	<i>Description</i>	<i>Example</i>
originalPartnerReferenceNo	String	O	64	Transaction identifier on service consumer system	2020102900 0000000000 01
originalReferenceNo	String	O	64	Transaction identifier on service provider system.	2020102977 7700000000 09
merchantId	String	O	64	Merchant identifier that is unique per each merchant	0000710001 0926
subMerchantId	String	O	32	Sub merchant ID	3109289249 49487
externalStoreId	String	O	64	External Store ID	1249289249 49487
additionalInfo	Object	O	N/A	Additional information for custom use that are not	{"deviceId": "12345679237", "channel": "mobilephone"}

<b>Parameter</b>	<b>Data Type</b>	<b>Mandatory</b>	<b>Length</b>	<b>Description</b>	<b>Example</b>
				provided by SNAP	

### Response Body

<b>Parameter</b>	<b>Data Type</b>	<b>Mandatory</b>	<b>Length</b>	<b>Description</b>	<b>Example</b>
responseCode	String	M	7	Response code	2006400
responseMessage	String	M	150	Response description	Successful
originalPartnerReferenceNo	String	O	64	Transaction identifier on service consumer system	20201029000000000001
originalReferenceNo	String	O	64	Transaction identifier on service provider system.	2020102977770000000009
amount	Object	O			
value	String	M	16,2	Net amount of the transaction. If it's IDR then value includes 2 decimal digits. e.g. IDR 10.000,- will be placed with 10000.00	10000.00
currency	String	M	3	Currency	IDR

<b>Parameter</b>	<b>Data Type</b>	<b>Mandatory</b>	<b>Length</b>	<b>Description</b>	<b>Example</b>
				(ISO4 217)	
paidTime	String	M	25	Transaction paid time. Format paid time: (ISO 8601) YYYY-MM-DDThh:mm:ss	2009-07-03T12:08:56+07:00
latestTransactionStatus	String	M	2	<b>00</b> = Success <b>01</b> = Initiated <b>02</b> = Paying <b>03</b> = Pending <b>04</b> = Refunded <b>05</b> = Canceled <b>06</b> = Failed <b>07</b> = Not found	00
transactionStatusDesc	String	O	50	Description status transaction	Success
additionalInfo	Object	O	N/A	Additional information for custom use that are not provided by SNAP	{"deviceId": "12345679237", "channel": "mobilephone"}

### Contoh Request

```
POST .../v1.0/auth/query HTTP/1.2
Content-type: application/json
Authorization: Bearer
gp9HjjEj813Y9JGoqwOeOPWbnt4CUvpIJbU1mMU4a11MNDZ7Sg5u9a"
```



```
Authorization-Customer: Bearer
fa8sjjEj813Y9JGoqwOeOPWbnt4CUpvIJbU1mMU4a11MNDZ7Sg5u9a"
X-TIMESTAMP: 2020-12-23T09:10:11+07:00
X-SIGNATURE:
85be817c55b2c135157c7e89f52499bf0c25ad6eeeb04a986e8c862561b19a5
ORIGIN: www.hostname.com
X-PARTNER-ID: 82150823919040624621823174737537
X-EXTERNAL-ID: 41807553358950093184162180797837
X-IP-ADDRESS: 172.24.281.24
X-DEVICE-ID: 09864ADCASA
X-LATITUDE: -6.108841
X-LONGITUDE: 106.7782137
CHANNEL-ID: 95221
{
  "originalPartnerReferenceNo": "202010290000000000000001",
  "originalReferenceNo": "202010297777000000000009",
  "merchantId": "00007100010926",
  "subMerchantId": "310928924949487",
  "externalStoreId": "124928924949487",
  "additionalInfo": {
    "deviceId": "12345679237",
    "channel": "mobilephone"
  }
}
```

### Contoh Response

```
Content-type: application/json
X-TIMESTAMP: 2020-12-23T09:10:18+07:00

{
  "responseCode": "2006400",
  "responseMessage": "Successful",
  "originalpartnerReferenceNo": "202010290000000000000001",
  "originalReferenceNo": "202010297777000000000009",
  "amount": {
    "value": "10000.00",
    "currency": "IDR"
  },
  "paidTime": "2009-07-03T12:08:56+07:00",
  "latestTransactionStatus": "00",
  "transactionStatusDesc": "success",
  "additionalInfo": {
    "deviceId": "12345679237",
    "channel": "mobilephone"
  }
}
```

### c. API Capture

#### Informasi Umum

API Capture bisa dijalankan terlebih dahulu lalu sebelum API Void

<b>Service Code</b>	65
<b>Name</b>	API Capture
<b>Version</b>	1.0
<b>HTTP Method</b>	POST
<b>Path</b>	.../{version}/auth/capture

#### Request Body

<i>Parameter</i>	<i>Data Type</i>	<i>Mandatory</i>	<i>Length</i>	<i>Description</i>	<i>Example</i>
originalReferenceNo	String	M	64	Transaction identifier on service provider system	2020102977 7700000000 09
originalPartnerReferenceNo	String	M	64	Transaction identifier on service consumer system	2020102900 0000000000 01
merchantId	String	M	64	Merchant identifier that is unique per each merchant	0000710001 0926
subMerchantId	String	O	32	Sub merchant ID	3109289249 49487
partnerCaptureNo	String	M	64	Capture identifier generated by the partner	0000710001 012344

<b>Parameter</b>	<b>Data Type</b>	<b>Mandatory</b>	<b>Length</b>	<b>Description</b>	<b>Example</b>
captureAmount	<i>Object</i>	O			
value	<i>String</i>	M	16,2	Capture amount. If it's IDR then value includes 2 decimal digits. e.g. IDR 10.000,- will be placed with 10000.00	12345678.00
currency	<i>String</i>	M	3	Currency (ISO 4217)	IDR
title	<i>String</i>	M	256	Capture title.	Confirmed
lastCapture	<i>String</i>	O	8	Flag to determine whether this is the last capture and void the rest of the money if there's any money left.	TRUE
additionalInfo	<i>Object</i>	O	N/A	Additional information for custom use that are not provided by SNAP	{ "deviceId": "12345679237", "channel": "mobilephone"}

## Response Body

<b>Parameter</b>	<b>Data Type</b>	<b>Mandatory</b>	<b>Length</b>	<b>Description</b>	<b>Example</b>
responseCode	String	M	7	Response code	2006500
responseMessage	String	M	150	Response description	Successful
originalReferenceNo	String	O	64	Transaction identifier on service provider system.	2020102977 7700000000 09
originalPartnerReferenceNo	String	O	64	Transaction identifier on service consumer system	2020102900 0000000000 01
partnerCaptureNo	String	O	64	Capture identifier generated by the partner	0000710001 012344
captureNo	String	C	64	PJSP's capture identifier. Used to trace the capture when there's any issue occurred.  Must be filled upon successful transaction.	2020101738 2190489801 2234423
captureAmount	Object	O			
value	String	M	16,2	Capture amount . If it's IDR then value includes	10000.00

<b>Parameter</b>	<b>Data Type</b>	<b>Mandatory</b>	<b>Length</b>	<b>Description</b>	<b>Example</b>
				2 decimal digits. e.g. IDR 10.000,- will be placed with 10000.00	
currency	String	M	3	Currency (ISO 4217)	IDR
captureTime	String	C	25	Capture time.  Format capture time: (ISO 8601) YYYY-MM-DDThh:mm:ss  Must be filled upon successful transaction	2009-07-03T12:08:56+07:00
additionalInfo	Object	O	N/A	Additional information for custom use that are not provided by SNAP	{"deviceId": "12345679237", "channel": "mobilephone"}

### Contoh Request

```
POST .../v1.0/auth/capture HTTP/1.2
Content-type: application/json
Authorization: Bearer
gp9HjjEj813Y9JGoqwOeOPWbnt4CUpvIJbU1mMU4a11MNDZ7Sg5u9a"
Authorization-Customer: Bearer
fa8sjjEj813Y9JGoqwOeOPWbnt4CUpvIJbU1mMU4a11MNDZ7Sg5u9a"
X-TIMESTAMP: 2020-12-23T09:12:11+07:00
```

X-SIGNATURE:  
85be817c55b2c135157c7e89f52499bf0c25ad6eebe04a986e8c862561b19a5  
ORIGIN: www.hostname.com  
X-PARTNER-ID: 82150823919040624621823174737537  
X-EXTERNAL-ID: 41807553358950093184162180797837  
X-IP-ADDRESS: 172.24.281.24  
X-DEVICE-ID: 09864ADCASA  
X-LATITUDE: -6.108841  
X-LONGITUDE: 106.7782137  
CHANNEL-ID: 95221

```
{
  "originalReferenceNo":"2020102977770000000009",
  "originalPartnerReferenceNo":"2020102900000000000001",
  "merchantId":"00007100010926",
  "subMerchantId":"310928924949487",
  "partnerCaptureNo":"0000710001012344",
  "captureAmount":{
    "value":"12345678.00",
    "currency":"IDR"
  },
  "title":"Confirmed",
  "lastCapture":"TRUE",
  "additionalInfo":{
    "deviceId":"12345679237",
    "channel":"mobilephone"
  }
}
```

## Contoh Response

Content-type: application/json  
X-TIMESTAMP: 2020-12-23T09:12:18+07:00

```
{
  "responseCode":"2006500",
  "responseMessage":"Successful",
  "originalReferenceNo":"2020102977770000000009",
  "originalPartnerReferenceNo":"2020102900000000000001",
  "partnerCaptureNo":"0000710001012344",
  "captureNo":"202010173821904898012234423",
  "captureAmount":{
    "value":"10000.00",
    "currency":"IDR"
  },
  "captureTime":"2009-07-03T12:08:56+07:00",
  "additionalInfo":{
    "deviceId":"12345679237",
```

```
    "channel": "mobilephone"  
  }  
}
```

#### d. API Capture Query

##### Informasi Umum

<b>Service Code</b>	66
<b>Name</b>	API Capture Query
<b>Version</b>	1.0
<b>HTTP Method</b>	POST
<b>Path</b>	.../{version}/auth/capture-query

##### Request Body

<b>Parameter</b>	<b>Data Type</b>	<b>Mandatory</b>	<b>Length</b>	<b>Description</b>	<b>Example</b>
originalReferenceNo	String	M	64	Transaction identifier on service provider system	2020102977 7700000000 09
originalPartnerReferenceNo	String	O	64	Transaction identifier on service consumer system	2020102900 0000000000 01
merchantId	String	M	64	Merchant identifier that is unique per each merchant	0000710001 0926
subMerchantId	String	O	32	Sub merchant ID	3109289249 49487
captureNo	String	O	64	PJSP's capture identifier. Used to trace the payment when there's any issue occurred.	2020101738 2190489801 2234423



<b>Parameter</b>	<b>Data Type</b>	<b>Mandatory</b>	<b>Length</b>	<b>Description</b>	<b>Example</b>
partnerCaptureNo	String	M	64	Capture identifier generated by the partner	0000710001012344
additionalInfo	Object	O	N/A	Additional information for custom use that are not provided by SNAP	{ "deviceId": "12345679237", "channel": "mobilephone"}

### Response Body

<b>Parameter</b>	<b>Data Type</b>	<b>Mandatory</b>	<b>Length</b>	<b>Description</b>	<b>Example</b>
responseCode	String	M	7	Response code	2006600
responseMessage	String	M	150	Response description	Successful
originalReferenceNo	String	O	64	Transaction identifier on service provider system.	2020102977770000000009
originalPartnerReferenceNo	String	O	64	Transaction identifier on service consumer system	20201029000000000001
captureNo	String	O	64	PJSP's capture identifier. Used to trace the capture when	202010173821904898012234423

<b>Parameter</b>	<b>Data Type</b>	<b>Mandatory</b>	<b>Length</b>	<b>Description</b>	<b>Example</b>
				there's any issue occurred.	
captureAmount	<i>Object</i>	O			
value	<i>String</i>	M	16,2	Capture amount. If it's IDR then value includes 2 decimal digits. e.g. IDR 10.000,- will be placed with 10000.00	10000.00
currency	<i>String</i>	M	3	Currency (ISO 4217)	IDR
captureTime	<i>String</i>	C	25	Capture time.  Must be filled upon successful transaction.  Format capture time: (ISO 8601) YYYY-MM-DDThh:mm:ss	2009-07-03T12:08:56+07:00
latestCapture Status	<i>String</i>	C	32	Capture status.  Must be filled upon successful transaction	SUCCESS

<b>Parameter</b>	<b>Data Type</b>	<b>Mandatory</b>	<b>Length</b>	<b>Description</b>	<b>Example</b>
				<b>INIT, SUCCESS, FAILED.</b>	
partnerCapture No	String	M	64	Capture identifier generated by the partner	0000710001 012344
additionalInfo	Object	O	N/A	Additional information for custom use that are not provided by SNAP	{"deviceId": "12345679237", "channel": "mobilephone"}

### Contoh Request

```

POST .../v1.0/auth/capture-query HTTP/1.2
Content-type: application/json
Authorization: Bearer
gp9HjjEj813Y9JGoqwOeOPWbnt4CUpvIJbU1mMU4a11MNDZ7Sg5u9a"
Authorization-Customer: Bearer
fa8sjjEj813Y9JGoqwOeOPWbnt4CUpvIJbU1mMU4a11MNDZ7Sg5u9a"
X-TIMESTAMP: 2020-12-23T09:15:11+07:00
X-SIGNATURE:
85be817c55b2c135157c7e89f52499bf0c25ad6eebe04a986e8c862561b19a5
ORIGIN: www.hostname.com
X-PARTNER-ID: 82150823919040624621823174737537
X-EXTERNAL-ID: 41807553358950093184162180797837
X-IP-ADDRESS: 172.24.281.24
X-DEVICE-ID: 09864ADCASA
X-LATITUDE: -6.108841
X-LONGITUDE: 106.7782137
CHANNEL-ID: 95221

{
  "originalReferenceNo": "2020102977770000000009",
  "originalPartnerReferenceNo": "2020102900000000000001",
  "merchantId": "00007100010926",
  "subMerchantId": "310928924949487",
  "captureNo": "202010173821904898012234423",

```

```
"partnerCaptureNo": "0000710001012344",
"additionalInfo": {
  "deviceId": "12345679237",
  "channel": "mobilephone"
}
}
```

## Contoh Response

Content-type: application/json  
X-TIMESTAMP: 2020-12-23T09:15:17+07:00

```
{
  "responseCode": "2006600",
  "responseMessage": "Successful",
  "originalReferenceNo": "20201029777700000000009",
  "originalPartnerReferenceNo": "20201029000000000000001",
  "captureNo": "202010173821904898012234423",
  "captureAmount": {
    "value": "10000.00",
    "currency": "IDR"
  },
  "captureTime": "2009-07-03T12:08:56+07:00",
  "latestCaptureStatus": "SUCCESS",
  "partnerCaptureNo": "0000710001012344",
  "additionalInfo": {
    "deviceId": "12345679237",
    "channel": "mobilephone"
  }
}
```

## e. API Void

### Informasi Umum

API Void bisa dijalankan terlebih dahulu lalu sebelum API Capture

<b>Service Code</b>	67
<b>Name</b>	API Void
<b>Version</b>	1.0
<b>HTTP Method</b>	POST
<b>Path</b>	.../{version}/auth/void

### Request Body

<b>Parameter</b>	<b>Data Type</b>	<b>Mandatory</b>	<b>Length</b>	<b>Description</b>	<b>Example</b>
originalReferenceNo	String	M	64	Transaction identifier on service provider system	2020102977 7700000000 09
originalPartnerReferenceNo	String	M	64	Transaction identifier on service consumer system	2020102900 0000000000 01
merchantId	String	M	64	Merchant identifier that is unique per each merchant	0000710001 0926
subMerchantId	String	O	32	Sub merchant ID	3109289249 49487
voidAmount	Object	O			
value	String	M	16,2	Void amount. If it's IDR then value includes 2 decimal digits.	10000.00

<b>Parameter</b>	<b>Data Type</b>	<b>Mandatory</b>	<b>Length</b>	<b>Description</b>	<b>Example</b>
				e.g. IDR 10.000,- will be placed with 10000.00	
currency	String	M	3	Currency (ISO 4217)	IDR
partnerVoidNo	String	M	64	Void identifier generated by the partner	3109289249 45645
voidRemaining Amount	String	O	8	Flag to determine whether this is the last void and void the rest of the money.	TRUE
reason	String	O	256	Void reason.	Shorter period/distance
additionalInfo	Object	O	N/A	Additional information for custom use that are not provided by SNAP	{"deviceId": "12345679237", "channel": "mobilephone"}

### Response Body

<b>Parameter</b>	<b>Data Type</b>	<b>Mandatory</b>	<b>Length</b>	<b>Description</b>	<b>Example</b>
responseCode	String	M	7	Response code	2006700

<b>Parameter</b>	<b>Data Type</b>	<b>Mandatory</b>	<b>Length</b>	<b>Description</b>	<b>Example</b>
responseMessage	String	M	150	Response description	Successful
originalReferenceNo	String	O	64	Transaction identifier on service provider system.	2020102977 7700000000 09
originalPartnerReferenceNo	String	O	64	Transaction identifier on service consumer system	2020102900 0000000000 01
voidNo	String	C	64	PJSP's void identifier. Used to trace the capture when there's any issue occurred. Must be filled upon successful transaction	2020101738 2190489801 2234423
partnerVoidNo	String	M	64	Void identifier generated by the partner	3109289249 45645
voidAmount	Object	O			
value	String	M	16,2	Void amount. If it's IDR then value includes 2 decimal digits. e.g. IDR 10.000,- will be placed with 10000.00	10000.00
currency	String	M	3	Currency (ISO 4217)	IDR

<b>Parameter</b>	<b>Data Type</b>	<b>Mandatory</b>	<b>Length</b>	<b>Description</b>	<b>Example</b>
voidTime	String	C	25	Void time.  Must be filled upon successful transaction  Format void time: (ISO 8601) YYYY-MM-DDThh:mm:ss	2009-07-03T12:08:56+07:00
additionalInfo	Object	O	N/A	Additional information for custom use that are not provided by SNAP	{"deviceId": "12345679237", "channel": "mobilephone"}

### Contoh Request

```

POST .../v1.0/auth/void HTTP/1.2
Content-type: application/json
Authorization: Bearer
gp9HjjEj813Y9JGoqwOeOPWbnt4CUvpIJbU1mMU4a11MNDZ7Sg5u9a"
Authorization-Customer: Bearer
fa8sjjEj813Y9JGoqwOeOPWbnt4CUvpIJbU1mMU4a11MNDZ7Sg5u9a"
X-TIMESTAMP: 2020-12-23T09:19:47+07:00
X-SIGNATURE:
85be817c55b2c135157c7e89f52499bf0c25ad6eebe04a986e8c862561b19a5
ORIGIN: www.hostname.com
X-PARTNER-ID: 82150823919040624621823174737537
X-EXTERNAL-ID: 41807553358950093184162180797837
X-IP-ADDRESS: 172.24.281.24
X-DEVICE-ID: 09864ADCASA
X-LATITUDE: -6.108841
X-LONGITUDE: 106.7782137
CHANNEL-ID: 95221

{
  "originalReferenceNo": "2020102977770000000009",
  "originalPartnerReferenceNo": "2020102900000000000001",
  "merchantId": "00007100010926",
  "subMerchantId": "310928924949487",

```



```
"voidAmount":{
  "value":"10000.00",
  "currency":"IDR"
},
"partnerVoidNo":"310928924945645",
"voidRemainingAmount":"TRUE",
"reason":"Shorter period/distance.",
"additionalInfo":{
  "deviceId":"12345679237",
  "channel":"mobilephone"
}
}
```

### Contoh Response

Content-type: application/json  
X-TIMESTAMP: 2020-12-23T09:19:56+07:00

```
{
  "responseCode":"2006700",
  "responseMessage":"Successful",
  "originalReferenceNo":"20201029777700000000009",
  "originalPartnerReferenceNo":"20201029000000000000001",
  "voidNo":"202010173821904898012234423",
  "partnerVoidNo":"310928924945645",
  "voidAmount":{
    "value":"10000.00",
    "currency":"IDR"
  },
  "voidTime":"2009-07-03T12:08:56+07:00",
  "additionalInfo":{
    "deviceId":"12345679237",
    "channel":"mobilephone"
  }
}
```

## f. API Void Query

### Informasi Umum

<b>Service Code</b>	68
<b>Name</b>	API Void Query
<b>Version</b>	1.0
<b>HTTP Method</b>	POST
<b>Path</b>	.../{version}/auth/void-query

### Request Body

<i>Parameter</i>	<i>Data Type</i>	<i>Mandatory</i>	<i>Length</i>	<i>Description</i>	<i>Example</i>
originalReferenceNo	String	M	64	Transaction identifier on service provider system	2020102977 7700000000 09
originalPartnerReferenceNo	String	O	64	Transaction identifier on service consumer system	2020102900 0000000000 01
merchantId	String	M	64	Merchant identifier that is unique per each merchant	0000710001 0926
subMerchantId	String	O	32	Sub merchant ID	3109289249 49487
voidNo	String	O	64	PJSP's void identifier. Used to trace the payment when there's any issue occurred.	2020101738 2190489801 2234423

<b>Parameter</b>	<b>Data Type</b>	<b>Mandatory</b>	<b>Length</b>	<b>Description</b>	<b>Example</b>
partnerVoidNo	String	M	64	Void identifier generated by the partner	2020101738 445452
additionalInfo	Object	O	N/A	Additional information for custom use that are not provided by SNAP	{"deviceId": "12345679237", "channel": "mobilephone"}

### Response Body

<b>Parameter</b>	<b>Data Type</b>	<b>Mandatory</b>	<b>Length</b>	<b>Description</b>	<b>Example</b>
responseCode	String	M	7	Response code	2006800
responseMessage	String	M	150	Response description	Successful
originalReferenceNo	String	O	64	Transaction identifier on service provider system.	2020102977 7700000000 09
originalPartnerReferenceNo	String	O	64	Transaction identifier on service consumer system	2020102900 0000000000 01
voidNo	String	O	64	PJSP's void identifier. Used to trace the capture when there's any issue occurred.	2020101738 2190489801 2234423

<b>Parameter</b>	<b>Data Type</b>	<b>Mandatory</b>	<b>Length</b>	<b>Description</b>	<b>Example</b>
voidAmount	<i>Object</i>	O			
value	<i>String</i>	M	16,2	Void amount. If it's IDR then value includes 2 decimal digits. e.g. IDR 10.000,- will be placed with 10000.00	10000.00
currency	<i>String</i>	M	3	Currency (ISO 4217)	IDR
voidTime	<i>String</i>	C	25	Void time.  Must be filled upon successful transaction  Format void time: (ISO 8601) YYYY-MM-DDThh:mm:ss	2009-07-03T12:08:56+07:00
latestVoidStatus	<i>String</i>	C	32	Void status.  Must be filled upon successful transaction  <b>INIT, SUCCESS, FAILED</b>	SUCCESS
partnerVoidNo	<i>String</i>	O	64	Void identifier generated by the partner	2020101738445452

<b>Parameter</b>	<b>Data Type</b>	<b>Mandatory</b>	<b>Length</b>	<b>Description</b>	<b>Example</b>
additionalInfo	Object	O	N/A	Additional information for custom use that are not provided by SNAP	{ "deviceId": "12345679237", "channel": "mobilephone"}

### Contoh Request

```

POST .../v1.0/auth/void-query HTTP/1.2
Content-type: application/json
Authorization: Bearer
gp9HjjEj813Y9JGoqwOeOPWbnt4CUpvIJbU1mMU4a11MNDZ7Sg5u9a"
Authorization-Customer: Bearer
fa8sjjEj813Y9JGoqwOeOPWbnt4CUpvIJbU1mMU4a11MNDZ7Sg5u9a"
X-TIMESTAMP: 2020-12-23T09:22:47+07:00
X-SIGNATURE:
85be817c55b2c135157c7e89f52499bf0c25ad6eebe04a986e8c862561b19a5
ORIGIN: www.hostname.com
X-PARTNER-ID: 82150823919040624621823174737537
X-EXTERNAL-ID: 41807553358950093184162180797837
X-IP-ADDRESS: 172.24.281.24
X-DEVICE-ID: 09864ADCASA
X-LATITUDE: -6.108841
X-LONGITUDE: 106.7782137
CHANNEL-ID: 95221

```

```

{
  "originalReferenceNo": "2020102977770000000009",
  "originalPartnerReferenceNo": "2020102900000000000001",
  "merchantId": "00007100010926",
  "subMerchantId": "310928924949487",
  "voidNo": "202010173821904898012234423",
  "partnerVoidNo": "2020101738445452",
  "additionalInfo": {
    "deviceId": "12345679237",
    "channel": "mobilephone"
  }
}

```

## Contoh Response

Content-type: application/json  
X-TIMESTAMP: 2020-12-23T09:22:56+07:00

```
{
  "responseCode": "2006800",
  "responseMessage": "Successful",
  "originalReferenceNo": "20201029777700000000009",
  "originalPartnerReferenceNo": "20201029000000000000001",
  "voidNo": "202010173821904898012234423",
  "voidAmount": {
    "value": "10000.00",
    "currency": "IDR"
  },
  "voidTime": "2009-07-03T12:08:56+07:00",
  "latestVoidStatus": "SUCCESS",
  "partnerVoidNo": "2020101738445452",
  "additionalInfo": {
    "deviceId": "12345679237",
    "channel": "mobilephone"
  }
}
```

## g. API Refund

### Informasi Umum

<b>Service Code</b>	69
<b>Name</b>	API Refund
<b>Version</b>	1.0
<b>HTTP Method</b>	POST
<b>Path</b>	.../{version}/auth/refund

### Request Body

<i>Parameter</i>	<i>Data Type</i>	<i>Mandatory</i>	<i>Length</i>	<i>Description</i>	<i>Example</i>
originalPartnerReferenceNo	String	M	64	Transaction identifier on service consumer system	2020102900 0000000000 01
originalReferenceNo	String	O	64	Transaction identifier on service provider system.	2020102977 7700000000 09
partnerRefundNo	String	M	64	ReferenceNumber from PJP AIS for the refund.	23985091820 4981205970
merchantId	String	O	64	Merchant identifier that is unique per each merchant	0000710001 0926
subMerchantId	String	O	32	Sub merchant ID	3109289249 49487
originalCaptureNo	String	C	64	PJSP's capture identifier. Used to trace the payment when there's any issue occurred.	2020101738 2190489801 2234423

<b>Parameter</b>	<b>Data Type</b>	<b>Mandatory</b>	<b>Length</b>	<b>Description</b>	<b>Example</b>
				Must be filled upon unsuccessful transaction.	
refundAmount	Object	O			
value	String	M	16,2	Refund amount. If it's IDR then value includes 2 decimal digits. e.g. IDR 10.000,- will be placed with 10000.00	12345678.00
currency	String	M	3	Currency (ISO 4217)	IDR
externalStoreId	String	O	64	External Store ID	1249289249 49487
reason	String	O	256	Refund reason	Customer complain
additionalInfo	Object	O	N/A	Additional information for custom use that are not provided by SNAP	{"deviceId": "12345679237", "channel": "mobilephone"}

### Response Body

<b>Parameter</b>	<b>Data Type</b>	<b>Mandatory</b>	<b>Length</b>	<b>Description</b>	<b>Example</b>
responseCode	String	M	7	Response code	2006900
responseMessage	String	M	150	Response description	Successful



<b>Parameter</b>	<b>Data Type</b>	<b>Mandatory</b>	<b>Length</b>	<b>Description</b>	<b>Example</b>
originalCaptureNo	String	C	64	PJSP's capture identifier. Used to trace the payment when there's any issue occurred.  Must be filled upon unsuccessful transaction	2020101738 2190489801 2234423
originalReferenceNo	String	C	64	Transaction identifier on service provider system.  Must be filled upon successful refund transaction	2020102977 7700000000 09
originalPartnerReferenceNo	String	O	64	Transaction identifier on service consumer system	2020102900 0000000000 01
partnerRefundNo	String	O	64	PJSP's refund identifier. Used to trace the capture when there's any issue occurred.	2020101738 2190489801 2234423

<b>Parameter</b>	<b>Data Type</b>	<b>Mandatory</b>	<b>Length</b>	<b>Description</b>	<b>Example</b>
refundNo	String	M	64	Refund Number	REF993883
refundAmount	Object	O			
value	String	M	16,2	Refund amount. If it's IDR then value includes 2 decimal digits. e.g. IDR 10.000,- will be placed with 10000.00	12345678.00
currency	String	M	3	Currency (ISO 4217)	IDR
refundTime	String	M	25	Refund time. Format refund time: (ISO 8601) YYYY-MM-DDThh:mm:ss	2020-12-23T09:19:47+07:00
additionalInfo	Object	O	N/A	Additional information for custom use that are not provided by SNAP	{"deviceId": "12345679237", "channel": "mobilephone"}

### Contoh Request

```
POST .../v1.0/auth/refund HTTP/1.2
Content-type: application/json
Authorization: Bearer
gp9HjjEj813Y9JGoqwOeOPWbnt4CUpvIJbU1mMU4a11MNDZ7Sg5u9a"
```

Authorization-Customer: Bearer  
fa8sjjEj813Y9JGoqwOeOPWbnt4CUpvIJbU1mMU4a11MNDZ7Sg5u9a"  
X-TIMESTAMP: 2020-12-23T09:22:47+07:00  
X-SIGNATURE:  
85be817c55b2c135157c7e89f52499bf0c25ad6eeeb04a986e8c862561b19a5  
ORIGIN: www.hostname.com  
X-PARTNER-ID: 82150823919040624621823174737537  
X-EXTERNAL-ID: 41807553358950093184162180797837  
X-IP-ADDRESS: 172.24.281.24  
X-DEVICE-ID: 09864ADCASA  
X-LATITUDE: -6.108841  
X-LONGITUDE: 106.7782137  
CHANNEL-ID: 95221

```
{
  "originalPartnerReferenceNo": "202010290000000000000001",
  "originalReferenceNo": "202010297777000000000009",
  "partnerRefundNo": "239850918204981205970",
  "merchantId": "00007100010926",
  "subMerchantId": "310928924949487",
  "originalCaptureNo": "202010173821904898012234423",
  "refundAmount": {
    "value": "12345678.00",
    "currency": "IDR"
  },
  "externalStoreId": "124928924949487",
  "reason": "Customer complain",
  "additionalInfo": {
    "deviceId": "12345679237",
    "channel": "mobilephone"
  }
}
```

## Contoh Response

Content-type: application/json  
X-TIMESTAMP: 2020-12-23T09:22:56+07:00

```
{
  "responseCode": "2006900",
  "responseMessage": "Successful",
  "originalCaptureNo": "20201017382190489801223442",
  "originalReferenceNo": "202010297777000000000009",
  "originalPartnerReferenceNo": "202010290000000000000001",
  "partnerRefundNo": "202010173821904898012234423",
  "refundNo": "REF993883",
  "refundAmount": {
    "value": "12345678.00",
```

```
    "currency": "IDR"
  },
  "refundTime": "2020-12-23T09:19:47+07:00",
  "additionalInfo": {
    "deviceId": "12345679237",
    "channel": "mobilephone"
  }
}
```

## 5.2.4. API Direct Debit BI-FAST

### a. Registrasi E-Mandate

#### Sequence Diagram

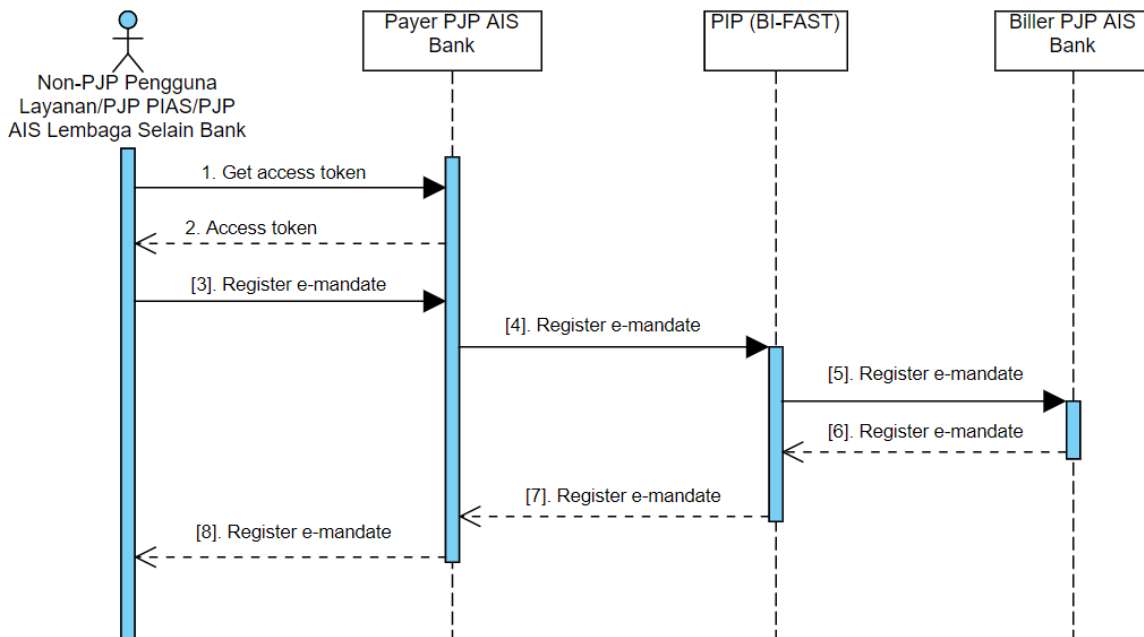

Sequence Diagram API Registrasi e-Mandate

#### Informasi Umum

<b>Service Code</b>	70
<b>Name</b>	API Registrasi e-Mandate
<b>Version</b>	1.0
<b>HTTP Method</b>	POST
<b>Path</b>	.../{version}/debit/fast-emandate

#### Request Body

<b>Parameter</b>	<b>Data Type</b>	<b>Mandatory</b>	<b>Length</b>	<b>Description</b>	<b>Example</b>
partnerReferenceNo	String	0	64	Transaction identifier on service	2020102900 0000000000 01

<b>Parameter</b>	<b>Data Type</b>	<b>Mandatory</b>	<b>Length</b>	<b>Description</b>	<b>Example</b>
				consumer system	
bankCode	String	M	3	Biller bank code based on Bank Indonesia Code	014
sourceAccount No	String	M	19	Account number to be billed	888801000157508
sourceAccount Name	String	M	100	Source Account Name	Saving
maxAmount	Object	O			
value	String	M	16,2	Maximum amount to be paid. If it's IDR then value includes 2 decimal digits. e.g. IDR 10.000,- will be placed with 10000.00	12345678.00
currency	String	M	3	Currency (ISO 4217)	IDR
billerId	String	M	30	Unique ID to identify biller	315134
billerName	String	M	50	Biller name	biller X

<b>Parameter</b>	<b>Data Type</b>	<b>Mandatory</b>	<b>Length</b>	<b>Description</b>	<b>Example</b>
customerId	String	M	45	Customer ID registered on biller	96891414
expiredDate	String	M	25	e-Mandate expiration date and time Format expired date time: (ISO 8601) YYYY-MM-DDThh:mm:ss	2022-12-22T08:01:16+07:00
additionalInfo	Object	O	N/A	Additional information for custom use that are not provided by SNAP	{"deviceId": "12345679237", "channel": "mobilephone"}

### Response Body

<b>Parameter</b>	<b>Data Type</b>	<b>Mandatory</b>	<b>Length</b>	<b>Description</b>	<b>Example</b>
responseCode	String	M	7	Response code	2007000
responseMessage	String	M	150	Response description	Successful
referenceNo	String	C	64	Transaction identifier on service provider system.	2020102977770000000009

<b>Parameter</b>	<b>Data Type</b>	<b>Mandatory</b>	<b>Length</b>	<b>Description</b>	<b>Example</b>
				Must be filled upon successful transaction	
partnerReferenceNo	String	O	64	Transaction identifier on service consumer system	2020102900000000000001
eMandateReffId	String	M	30	Unique key to identify an e-Mandate registration	9a8fau6d81had833bas7184
additionalInfo	Object	O	N/A	Additional information for custom use that are not provided by SNAP	{"deviceId": "12345679237", "channel": "mobilephone"}

### Contoh Request

```

POST .../v1.0/debit/fast-emandate HTTP/1.2
Content-type: application/json
Authorization: Bearer
gp9HjjEj813Y9JGoqwOeOPWbnt4CUpvIJbU1mMU4a11MNDZ7Sg5u9a"
Authorization-Customer: Bearer
fa8sjjEj813Y9JGoqwOeOPWbnt4CUpvIJbU1mMU4a11MNDZ7Sg5u9a"
X-TIMESTAMP: 2020-12-22T08:12:16+07:00
X-SIGNATURE:
85be817c55b2c135157c7e89f52499bf0c25ad6eebe04a986e8c862561b19a5
ORIGIN: www.hostname.com
X-PARTNER-ID: 82150823919040624621823174737537
X-EXTERNAL-ID: 41807553358950093184162180797837
X-IP-ADDRESS: 172.24.281.24
X-DEVICE-ID: 09864ADCASA
X-LATITUDE: -6.1617169
X-LONGITUDE: 106.6643946

```



CHANNEL-ID: 95221

```
{
  "partnerReferenceNo":"2020102900000000000001",
  "bankCode":"014",
  "sourceAccountNo":"888801000157508",
  "sourceAccountName":"Saving",
  "maxAmount":{
    "value":"12345678.00",
    "currency":"IDR"
  },
  "billerId":"315134",
  "billerName":"biller X",
  "customerId":"96891414",
  "expiredDatetime":"2022-12-22T08:01:16+07:00",
  "additionalInfo":{
    "deviceId":"12345679237",
    "channel":"mobilephone"
  }
}
```

### Contoh Response

Content-type: application/json  
X-TIMESTAMP: 2020-12-22T08:12:22+07:00

```
{
  "responseCode":"2007000",
  "responseMessage":"Successful",
  "referenceNo":"20201029777700000000009",
  "partnerReferenceNo":"2020102900000000000001",
  "eMandateReffId":"9a8fau6d81had833bas7184",
  "additionalInfo":{
    "deviceId":"12345679237",
    "channel":"mobilephone"
  }
}
```

## b. Trigger Direct Debit Transfer

### Sequence Diagram

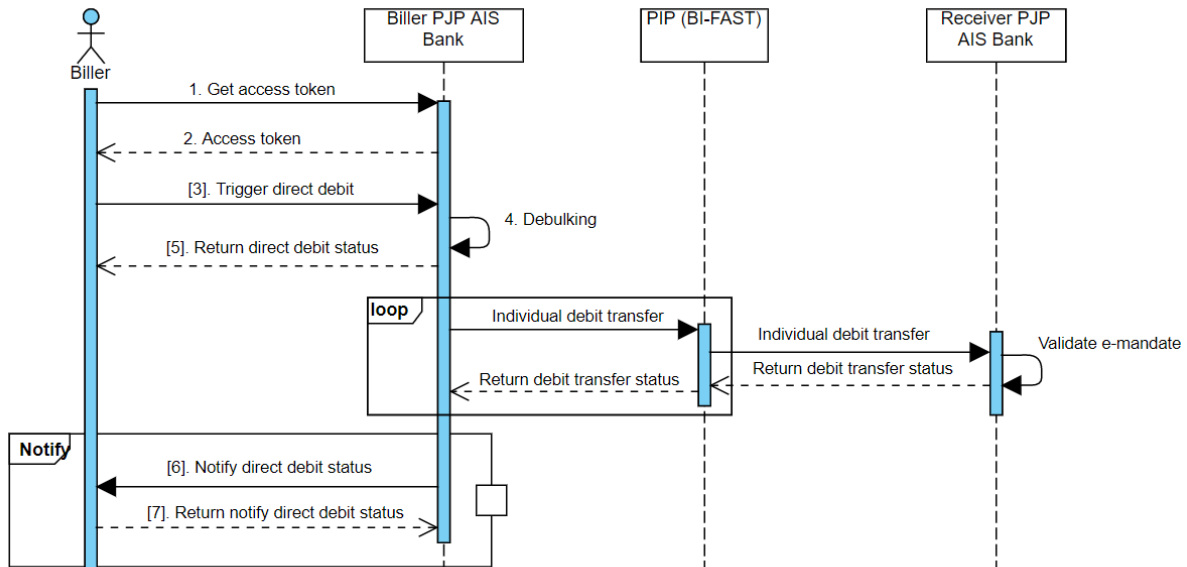

Sequence Diagram API Trigger Direct Debit Transfer

### Informasi Umum

<b>Service Code</b>	71
<b>Name</b>	API Registrasi e-Mandate
<b>Version</b>	1.0
<b>HTTP Method</b>	POST
<b>Path</b>	.../{version}/debit/fast-payment

### Request Body

<b>Parameter</b>	<b>Data Type</b>	<b>Mandatory</b>	<b>Length</b>	<b>Description</b>	<b>Example</b>
partnerReferenceNo	String	M	64	Transaction identifier on service consumer system	2020102900 0000000000 01
currency	String	O	3	Currency Type	IDR

<b>Parameter</b>	<b>Data Type</b>	<b>Mandatory</b>	<b>Length</b>	<b>Description</b>	<b>Example</b>
customerReference	String	M	30	Reference Number / No Referral / Transaction ID	10052019
feeType	String	O	25	To whom the fee will be charged  <b>OUR</b> = Fee is charged to the sender (default) <b>BEN</b> = Fee is charged to the recipient <b>SHA 1000</b> = Fee is shared between sender and recipient, with sender is charged Rp 1.000,00 and the recipient will be charged the rest	BEN
remark	String	O	50	Remark/transaction description	remark test
beneficiaryAccountNo	String	M	19	Biller account	888801000157508
beneficiaryAccountName	String	M	100	Biller account Account Name	Yories Yolanda

<b>Parameter</b>	<b>Data Type</b>	<b>Mandatory</b>	<b>Length</b>	<b>Description</b>	<b>Example</b>
transactionDate	String	M	25	Transaction date : ISO 8601 YYYY-MM-DDThh:mm:ss	2019-07-03T12:08:56+07:00
bankCode	String	M	3	Bank code based on Bank Indonesia Code	014
sourceAccount No	String	M	34	Debited customer account number	888801000003301
sourceAccount Name	String	M	100	Debited customer account Name	Saving
amount	Object	O			
value	String	M	16,2	Debit amount. If it's IDR then value includes 2 decimal digits. e.g. IDR 10.000,- will be placed with 10000.00	12345678.00
currency	String	M	3	Currency (ISO 4217)	IDR
eMandateReffId	String	M	30	Unique key to identify an e-Mandate registration	9a8fau6d81had833bas7184

<b>Parameter</b>	<b>Data Type</b>	<b>Mandatory</b>	<b>Length</b>	<b>Description</b>	<b>Example</b>
additionalInfo	Object	O	N/A	Additional information for custom use that are not provided by SNAP	{ "deviceId": "12345679237", "channel": "mobilephone"}

### Response Body

<b>Parameter</b>	<b>Data Type</b>	<b>Mandatory</b>	<b>Length</b>	<b>Description</b>	<b>Example</b>
responseCode	String	M	7	Response code	2007100
responseMessage	String	M	150	Response description	Successful
referenceNo	String	C	64	Transaction identifier on service provider system.  Must be filled upon successful transaction	2020102977 7700000000 09
partnerReferenceNo	String	O	64	Transaction identifier on service consumer system	2020102900 0000000000 01
additionalInfo	Object	O	N/A	Additional information for custom use that are not provided by SNAP	{ "deviceId": "12345679237", "channel": "mobilephone"}

## Contoh Request

```
POST .../v1.0/debit/fast-payment HTTP/1.2
Content-type: application/json
Authorization: Bearer
gp9HjjEj813Y9JGoqwOeOPWbnt4CUpvIJbU1mMU4a11MNDZ7Sg5u9a"
Authorization-Customer: Bearer
fa8sjjEj813Y9JGoqwOeOPWbnt4CUpvIJbU1mMU4a11MNDZ7Sg5u9a"
X-TIMESTAMP: 2020-12-22T08:26:16+07:00
X-SIGNATURE:
85be817c55b2c135157c7e89f52499bf0c25ad6eeeb04a986e8c862561b19a5
ORIGIN: www.hostname.com
X-PARTNER-ID: 82150823919040624621823174737537
X-EXTERNAL-ID: 41807553358950093184162180797837
X-IP-ADDRESS: 172.24.281.24
X-DEVICE-ID: 09864ADCASA
X-LATITUDE: -6.1617169
X-LONGITUDE: 106.6643946
CHANNEL-ID: 95221
```

```
{
  "partnerReferenceNo": "2020102900000000000001",
  "currency": "IDR",
  "customerReference": "10052019",
  "feeType": "BEN",
  "remark": "remark test",
  "beneficiaryAccountNo": "888801000157508",
  "beneficiaryAccountName": "Yories Yolanda",
  "transactionDate": "2019-07-03T12:08:56+07:00",
  "bankCode": "014",
  "sourceAccountNo": "888801000003301",
  "sourceAccountName": "Saving",
  "amount": {
    "value": "12345678.00",
    "currency": "IDR"
  },
  "eMandateReffId": "9a8fau6d81had833bas7184",
  "additionalInfo": {
    "deviceId": "12345679237",
    "channel": "mobilephone"
  }
}
```

## Contoh Response

```
Content-type: application/json
X-TIMESTAMP: 2020-12-22T08:26:30+07:00
```

```
{
```

```
"responseCode":"2007100",
"responseMessage":"Successful",
"referenceNo":"2020102977770000000009",
"partnerReferenceNo":"2020102900000000000001",
"additionalInfo":{
  "deviceId":"12345679237",
  "channel":"mobilephone"
}
}
```

### c. Notify

#### Sequence Diagram

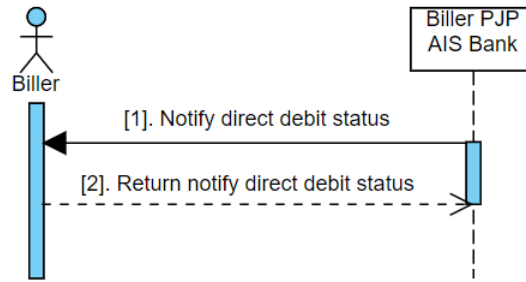

Sequence Diagram API Notify - Direct Debit

#### Informasi Umum

<b>Service Code</b>	72
<b>Name</b>	API Notify
<b>Version</b>	1.0
<b>HTTP Method</b>	POST
<b>Path</b>	.../{version}/debit/fast-notify

#### Request Body

<b>Parameter</b>	<b>Data Type</b>	<b>Mandatory</b>	<b>Length</b>	<b>Description</b>	<b>Example</b>
originalReferenceNo	String	M	64	Original transaction identifier on service provider system	2020102977 7700000000 09
originalPartnerReferenceNo	String	O	64	Original transaction identifier on service consumer system	2020102900 0000000000 01



<b>Parameter</b>	<b>Data Type</b>	<b>Mandatory</b>	<b>Length</b>	<b>Description</b>	<b>Example</b>
originalExternalId	String	O	19	Original Customer Reference Number	10052019
transactionStatus	String	M	2	<b>00</b> = Success <b>01</b> = Initiated <b>02</b> = Paying <b>03</b> = Pending <b>04</b> = Refunded <b>05</b> = Canceled <b>06</b> = Failed <b>07</b> = Not found	00
transactionStatusDesc	String	O	50	Description status transaction	Success
eMandateReffId	String	M	30	Unique key to identify an e-Mandate registration	9a8fau6d81had833bas7184
sourceAccountNo	String	M	34	Debited customer account number	888801000003301
sourceAccountName	String	M	100	Debited customer account Name	Saving
amount	Object	O			
value	String	M	16,2	Net amount of the transaction.	12345678.00

<b>Parameter</b>	<b>Data Type</b>	<b>Mandatory</b>	<b>Length</b>	<b>Description</b>	<b>Example</b>
				If it's IDR then value includes 2 decimal digits. e.g. IDR 10.000,- will be placed with 10000.00	
currency	String	M	3	Currency (ISO 4217)	IDR
traceNo	String	O	16	Number for tracking to destination bank	13415141
additionalInfo	Object	O	N/A	Additional information for custom use that are not provided by SNAP	{"deviceId": "12345679237", "channel": "mobilephone"}

### Response Body

<b>Parameter</b>	<b>Data Type</b>	<b>Mandatory</b>	<b>Length</b>	<b>Description</b>	<b>Example</b>
responseCode	String	M	7	Response code	2007200
responseMessage	String	M	150	Response description	Successful
additionalInfo	Object	O	N/A	Additional information for custom use that are not	{"deviceId": "12345679237", "channel": "mobilephone"}

				provided by SNAP	
--	--	--	--	---------------------	--

### Contoh Request

```

POST .../v1.0/debit/fast-notify HTTP/1.2
Content-type: application/json
Authorization: Bearer
gp9HjjEj813Y9JGoqwOeOPWbnt4CUpvIJbU1mMU4a11MNDZ7Sg5u9a"
Authorization-Customer: Bearer
fa8sjjEj813Y9JGoqwOeOPWbnt4CUpvIJbU1mMU4a11MNDZ7Sg5u9a"
X-TIMESTAMP: 2020-12-22T08:26:16+07:00
X-SIGNATURE:
85be817c55b2c135157c7e89f52499bf0c25ad6eebe04a986e8c862561b19a5
ORIGIN: www.hostname.com
X-PARTNER-ID: 82150823919040624621823174737537
X-EXTERNAL-ID: 41807553358950093184162180797837
X-IP-ADDRESS: 172.24.281.24
X-DEVICE-ID: 09864ADCASA
X-LATITUDE: -6.1617169
X-LONGITUDE: 106.6643946
CHANNEL-ID: 95221

{
  "originalReferenceNo": "2020102977770000000009",
  "originalPartnerReferenceNo": "2020102900000000000001",
  "originalExternalId": "10052019",
  "transactionStatus": "00",
  "transactionStatusDesc": "success",
  "eMandateReffId": "9a8fau6d81had833bas7184",
  "sourceAccountNo": "888801000003301",
  "sourceAccountName": "Saving",
  "amount": {
    "value": "12345678.00",
    "currency": "IDR"
  },
  "traceNo": "13415141",
  "additionalInfo": {
    "deviceId": "12345679237",
    "channel": "mobilephone"
  }
}

```

## Contoh Response

Content-type: application/json  
X-TIMESTAMP: 2020-12-22T08:26:30+07:00

```
{  
  "responseCode": "2007200",  
  "responseMessage": "Successful",  
  "additionalInfo": {  
    "deviceId": "12345679237",  
    "channel": "mobilephone"  
  }  
}
```

## 6. Informasi Lainnya

### 6.1. Response Code

Response status merupakan informasi yang diberikan oleh service provider kepada service consumer pada response body, sebagai indikasi hasil dari pemrosesan request yang diterima.

Response status terdiri dari 2 komponen, yaitu kode (response code) dan deskripsinya (response message).

Komponen	Tipe Data	Length	Keterangan
responseCode	String	7	<b>response code = HTTP status code + service code + case code</b>
responseMessage	String	150	

#### Daftar Response Code

Category	HTTP Status Code	Service Code	Case Code	Response Message	Description
Success	200	any	00	Successful	Successful
Success	202	any	00	Request In Progress	Transaction still on process
System	400	any	00	Bad Request	General request failed error, including message parsing failed.
Message	400	any	01	Invalid Field Format {field name}	Invalid format
Message	400	any	02	Invalid Mandatory Field {field name}	Missing or invalid format on mandatory field
System	401	any	00	Unauthorized . [reason]	General unauthorized error (No Interface Def, API is Invalid, Oauth Failed, Verify Client Secret Fail, Client Forbidden Access API, Unknown Client, Key not Found)
System	401	any	01	Invalid Token (B2B)	Token found in request is invalid (Access Token Not

Category	HTTP Status Code	Service Code	Case Code	Response Message	Description
					Exist, Access Token Expiry)
System	401	any	02	Invalid Customer Token	Token found in request is invalid (Access Token Not Exist, Access Token Expiry)
System	401	any	03	Token Not Found (B2B)	Token not found in the system. This occurs on any API that requires token as input parameter
System	401	any	04	Customer Token Not Found	Token not found in the system. This occurs on any API that requires token as input parameter
Business	403	any	00	Transaction Expired	Transaction expired
System	403	any	01	Feature Not Allowed [Reason]	This merchant is not allowed to call Direct Debit APIs
Business	403	any	02	Exceeds Transaction Amount Limit	Exceeds Transaction Amount Limit
Business	403	any	03	Suspected Fraud	Suspected Fraud
Business	403	any	04	Activity Count Limit Exceeded	Too many request, Exceeds Transaction Frequency Limit
Business	403	any	05	Do Not Honor	Account or User status is abnormal
System	403	any	06	Feature Not Allowed At This Time. [reason]	Cut off In Progress
Business	403	any	07	Card Blocked	The payment card is blocked
Business	403	any	08	Card Expired	The payment card is expired
Business	403	any	09	Dormant Account	The account is dormant
Business	403	any	10	Need To Set Token Limit	Need to set token limit
System	403	any	11	OTP Blocked	OTP has been blocked
System	403	any	12	OTP Lifetime Expired	OTP has been expired

Category	HTTP Status Code	Service Code	Case Code	Response Message	Description
System	403	any	13	OTP Sent To Cardholder	initiates request OTP to the issuer
Business	403	any	14	Insufficient Funds	Insufficient Funds
Business	403	any	15	Transaction Not Permitted.[reason]	Transaction Not Permitted
Business	403	any	16	Suspend Transaction	Suspend Transaction
Business	403	any	17	Token Limit Exceeded	Purchase amount exceeds the token limit set prior
Business	403	any	18	Inactive Card/Account/ Customer	Indicates inactive account
Business	403	any	19	Merchant Blacklisted	Merchant is suspended from calling any APIs
Business	403	any	20	Merchant Limit Exceed	Merchant aggregated purchase amount on that day exceeds the agreed limit
Business	403	any	21	Set Limit Not Allowed	Set limit not allowed on particular token
Business	403	any	22	Token Limit Invalid	The token limit desired by the merchant is not within the agreed range between the merchant and the Issuer
Business	403	any	23	Account Limit Exceed	Account aggregated purchase amount on that day exceeds the agreed limit
Business	404	any	00	Invalid Transaction Status	Invalid transaction status
Business	404	any	01	Transaction Not Found	Transaction not found
System	404	any	02	Invalid Routing	Invalid Routing
System	404	any	03	Bank Not Supported By Switch	Bank not supported by switch

Category	HTTP Status Code	Service Code	Case Code	Response Message	Description
Business	404	any	04	Transaction Cancelled	Transaction is cancelled by customer
Business	404	any	05	Merchant Is Not Registered For Card Registration Services	Merchant is not registered for Card Registration services
System	404	any	06	Need To Request OTP	Need to request OTP
System	404	any	07	Journey Not Found	The journeyID cannot be found in the system
Business	404	any	08	Invalid Merchant	Merchant does not exist or status abnormal
Business	404	any	09	No Issuer	No issuer
System	404	any	10	Invalid API Transition	Invalid API transition within a journey
Business	404	any	11	Invalid Card/Account/ Customer [info]/Virtual Account	Card information may be invalid, or the card account may be blacklisted, or Virtual Account number maybe invalid.
Business	404	any	12	Invalid Bill/Virtual Account [Reason]	The bill is blocked/suspended/not found.  Virtual account is suspend/not found.
Business	404	any	13	Invalid Amount	The amount doesn't match with what supposed to
Business	404	any	14	Paid Bill	The bill has been paid
System	404	any	15	Invalid OTP	OTP is incorrect
Business	404	any	16	Partner Not Found	Partner number can't be found
Business	404	any	17	Invalid Terminal	Terminal does not exist in the system
Business	404	any	18	Inconsistent Request	Inconsistent request parameter found for the same partner reference number/transaction id  It can be considered as failed in transfer debit,



Category	HTTP Status Code	Service Code	Case Code	Response Message	Description
					<p>but it should be considered as success in transfer credit.</p> <p>Considered as success:</p> <ul style="list-style-type: none"> <li>- Transfer credit = (i) Intrabank transfer; (ii) Interbank transfer; (iii) RTGS transfer; (iv) SKNBI transfer;</li> <li>- Virtual account = (i) Payment VA; (ii) Payment to VA;</li> <li>- Transfer debit = (i) Refund payment; (ii) Void;</li> </ul> <p>Considered as failed:</p> <ul style="list-style-type: none"> <li>- Transfer credit = (i) Transfer to OTC;</li> <li>- Transfer debit = (i) Direct debit payment; (ii) QR CPM payment; (iii) Auth payment; (iv) Capture;</li> </ul>
Business	404	any	19	Invalid Bill/Virtual Account	<p>The bill is expired.</p> <p>Virtual account is expired.</p>
System	405	any	00	Requested Function Is Not Supported	Requested function is not supported
Business	405	any	01	Requested Operation Is Not Allowed	Requested operation to cancel/refund transaction is not allowed at this time.
System	409	any	00	Conflict	Cannot use same X-EXTERNAL-ID in same day
System	409	any	01	Duplicate partnerReferenceNo	Transaction has previously been processed indicates the

Category	HTTP Status Code	Service Code	Case Code	Response Message	Description
					same partnerReferenceNo already success
System	429	any	00	Too Many Requests	Maximum transaction limit exceeded
System	500	any	00	General Error	General Error
System	500	Any	01	Internal Server Error	Unknown Internal Server Failure, Please retry the process again
System	500	Any	02	External Server Error	Backend system failure, etc
System	504	any	00	Timeout	timeout from the issuer

# LAMPIRAN

## Lampiran penjelasan detail revisi-1

No. API	API	No. Sub-API	Sub-API	Service Code	Sub-service	Keterangan Revisi
1	Registration	1	API Card Registration	1	API Card Registration	1.2.1. API Card RegistrationRequest Body 1. Parameter expiredDatetime: a. Ubah Data Type dari "Datetime" menjadi "String". b. Ubah Length dari "Format: ISO 8601" menjadi "25". c. Tambah informasi di bagian Description. 2. Parameter limit : Ubah Length dari "17,3" menjadi "17,2".  Response Body 1. Parameter referenceNo: Hapus Description "Must be filled...".
				2	API Card Registration – Set Limit	1.2.2. API Card Registration – Set Limit Request Body 1. Parameter limit: Ubah Length dari "17,3" menjadi "17,2".  Response Body 1. Parameter referenceNo: Hapus Description "Must be filled...".
				3	API Card Registration Inquiry	
				4	API Verify OTP (Direct Integration)	
				5	API Card Registration Unbinding	1.2.5. API Card Registration Unbinding Request Body 1. Parameter journeyId: Ubah parameter sesuai camelcase dari "journeyID" menjadi "journeyId". 2. Parameter transactionDate: a. Ubah Data type dari "Int" menjadi "String". b. Ubah Description  Response Body 1. Ubah parameter sesuai camelcase dari "journeyID" menjadi "journeyId".  Contoh Response 1. Hapus tutup kurung kurawal "]" sebelum field additionalInfo.  Contoh Response 1. Hapus tutup kurung kurawal "]" sebelum field additionalInfo.
		6	API Account Creation			
		7	API Account Binding			
		8	API Account Binding Inquiry			
		9	API Account Unbinding	1.2.9. API Account UnbindingResponse Body 1. Parameter referenceNo: a. Ubah Mandatory dari "C O" menjadi "O". b. Hapus Description "Must be filled...".		
		10	API Get OAuth URL	1.2.10. API Get OAuth URLRequest parameter 1. Parameter verifiedTime: a. Ubah Length dari "ISO 8601" jadi "25". b. Tambah informasi pada Description. 2. Parameter seamlessSign: Tambah informasi pada Description.  Response Body 1. Parameter authCode: Ubah Data type dari "S" menjadi "String".		
		81	API OTP	1.2.11 OTP Request Body 1. Parameter journeyId: Ubah parameter sesuai camelcase dari "journeyID" menjadi "journeyId". 2. Parameter bankCardToken: a. Ubah Mandatory dari "M" menjadi "C". b. Tambah informasi pada Description. 3. Parameter otpTrxCode: a. Ubah Mandatory dari kosong menjadi "O". b. Tambah informasi pada Description. c. Tambah Example "54".		
2	Balance Inquiry	3	API Balance Inquiry	11	API Balance Inquiry	2.2.1. API Balance InquiryResponse Body 1. Parameter referenceNo: Hapus Description "Must be filled...". 2. Parameter registrationStatusCode: Ubah Example dari "1" menjadi "0001". 3. Parameter status: Ubah Description.  Contoh Response 1. Ubah field "accountInfo" menjadi "accountInfos".

No. API	API	No. Sub-API	Sub-API	Service Code	Sub-service	Keterangan Revisi
3	Transaction History	4	API Transaction History List	12	API Transaction History List	<p>3.2.1. API Transaction History</p> <p>ListRequest Body</p> <ol style="list-style-type: none"> <li>Parameter fromDateTime: <ol style="list-style-type: none"> <li>Ubah Data Type dari "ISODatetime" menjadi "String".</li> <li>Ubah Description</li> <li>Ubah Example dari "...-07:00" menjadi "...+07:00".</li> </ol> </li> <li>Parameter toDateTime: <ol style="list-style-type: none"> <li>Ubah Data Type dari "ISODatetime" menjadi "String".</li> <li>Ubah Description</li> <li>Ubah Example dari "...-07:00" menjadi "...+07:00".</li> </ol> </li> <li>Parameter pageSize: Ubah Data Type dari "Int" menjadi "Integer".</li> <li>Parameter pageNumber: Ubah Data Type dari "Int" menjadi "Integer".</li> </ol> <p>Response Body</p> <ol style="list-style-type: none"> <li>Parameter referenceNo: Hapus Description "Must be filled...".</li> <li>Parameter dateTime: <ol style="list-style-type: none"> <li>Ubah Data Type dari "ISODatetime" menjadi "String".</li> <li>Ubah Description.</li> </ol> </li> </ol> <p>Contoh Request</p> <ol style="list-style-type: none"> <li>Field fromDateTime dan toDateTime: ubah dari "...-07:00" menjadi "...+07:00".</li> </ol> <p>Contoh Response</p> <ol style="list-style-type: none"> <li>Field dateTime: ubah dari "...-07:00" menjadi "...+07:00".</li> </ol>
		5	API Transaction History Detail	13	API Transaction History Detail	<p>3.2.2. API Transaction History Detail</p> <p>Response Body</p> <ol style="list-style-type: none"> <li>Parameter cancelledTime: <ol style="list-style-type: none"> <li>Ubah Data Type dari "ISODatetime" menjadi "String".</li> <li>Tambah Description.</li> <li>Ubah Example dari "...-07:00" menjadi "...+07:00".</li> </ol> </li> <li>Parameter dateTime: <ol style="list-style-type: none"> <li>Ubah Data Type dari "ISODatetime" menjadi "String".</li> <li>Tambah Description.</li> <li>Ubah Example dari "...-07:00" menjadi "...+07:00".</li> </ol> </li> <li>Parameter refundAmount: Ubah parameter dari "RefundAmount" menjadi "refundAmount".</li> <li>Parameter Type: Tambah Description.</li> </ol>
		6	API Bank Statement	14	API Bank Statement	<p>3.2.3. API Bank Statement</p> <p>Request Body</p> <ol style="list-style-type: none"> <li>Parameter accountNo: Ubah Description.</li> <li>Parameter fromDateTime: <ol style="list-style-type: none"> <li>Ubah Data Type dari "ISODatetime" menjadi "String".</li> <li>Tambah informasi di Description</li> <li>Ubah Example dari "...-07:00" menjadi "...+07:00".</li> </ol> </li> <li>Parameter toDateTime: <ol style="list-style-type: none"> <li>Ubah Data Type dari "ISODatetime" menjadi "String".</li> <li>Tambah informasi di Description</li> <li>Ubah Example dari "...-07:00" menjadi "...+07:00".</li> </ol> </li> </ol> <p>Response Body</p> <ol style="list-style-type: none"> <li>Parameter amount: Ubah sesuai camelcase dari "Amount" menjadi "amount".</li> <li>Parameter dateTime: Tambah informasi di Description.</li> <li>Parameter lastRecordDateTime: <ol style="list-style-type: none"> <li>Tambah informasi di Description</li> <li>Ubah Example dari "...-07:00" menjadi "...+07:00".</li> </ol> </li> <li>Parameter detailData: Ubah Data Type dari "Object" menjadi "Array of Object".</li> <li>Parameter startAmount: Ubah Data Type dari "Object" menjadi "Array of Object".</li> <li>Parameter endAmount: Ubah Data Type dari "Object" menjadi "Array of Object".</li> <li>Parameter transactionDate: <ol style="list-style-type: none"> <li>Ubah Data Type dari "ISODatetime" menjadi "String".</li> <li>Tambah informasi di Description</li> <li>Ubah Example dari "...-07:00" menjadi "...+07:00".</li> </ol> </li> </ol> <p>Contoh Request</p> <ol style="list-style-type: none"> <li>Field fromDateTime dan toDateTime: ubah dari "...-07:00" menjadi "...+07:00".</li> </ol> <p>Contoh Response</p> <ol style="list-style-type: none"> <li>Field transactionDate: ubah dari "...-07:00" menjadi "...+07:00".</li> </ol>
				15	API Internal Account Inquiry	<p>4.2.1.1. Internal Account Inquiry</p> <p>Request Body</p> <ol style="list-style-type: none"> <li>Parameter referenceNo: Hapus Description "Must be filled...".</li> </ol>

No. API	API	No. Sub-API	Sub-API	Service Code	Sub-service	Keterangan Revisi
		7	Intrabank Transfer	17	API Intrabank Transfer	<p>4.2.2. API Trigger Transfer: Hapus kata "Trigger" menjadi "API Transfer"</p> <p>4.2.2.1. Intrabank Transfer</p> <p>1. Hapus kata "Trigger" pada keterangan Sequence diagram dan Informasi umum bagian Name menjadi "Api Intrabank Transfer".</p> <p>Request Body</p> <p>1. Parameter feeType:</p> <ol style="list-style-type: none"> <li>Tambah informasi di Description</li> <li>Ubah Example</li> </ol> <p>2. Parameter transactionDate: Ubah Description</p> <p>3. Tambah field parameter sehubungan dengan permintaan laporan PPAK mengenai Data Pengirim (Sender) atas transaksi transfer dana:</p> <ol style="list-style-type: none"> <li>Tambah parameter originatorInfos.</li> <li>Tambah parameter originatorCustomerNo.</li> <li>Tambah parameter originatorCustomerName.</li> </ol> <p>Response Body</p> <p>1. Parameter transactionDate: Ubah Description.</p> <p>2. Tambah field parameter sehubungan dengan permintaan laporan PPAK mengenai Data Pengirim (Sender) atas transaksi transfer dana:</p> <ol style="list-style-type: none"> <li>Tambah parameter originatorInfos.</li> <li>Tambah parameter originatorCustomerNo.</li> <li>Tambah parameter originatorCustomerName.</li> <li>Tambah parameter OriginatorBankCode</li> </ol> <p>Contoh request dan Response: Tambah contoh originatorInfos.</p>
		8	Interbank Transfer	16	API Eksternal Account Inquiry	<p>4.2.1.2. Eksternal Account Inquiry</p> <p>1. Ubah Object pada gambar Sequence Diagram dari "PIP GPN" menjadi "PIP GPN/BI-FAST".</p> <p>Response Body</p> <p>1. Parameter referenceNo: Hapus Description "Must be filled...".</p>
				18	API Interbank Transfer	<p>4.2.2.2. Interbank Transfer</p> <p>1. Hapus kata "Trigger" pada nama sSub-API, keterangan Sequence diagram dan Informasi umum bagian Name menjadi "Api Interbank Transfer".</p> <p>Request Body</p> <p>1. Parameter customerReference: Ubah Mandatory dari "MO" menjadi "M".</p> <p>2. Parameter transactionDate:</p> <ol style="list-style-type: none"> <li>Ubah Description</li> <li>Ubah Example dari "...-07:00" menjadi "...+07:00".</li> </ol> <p>3. Parameter feeType:</p> <ol style="list-style-type: none"> <li>Tambah informasi di Description</li> <li>Ubah example.</li> </ol> <p>4. Tambah field parameter sehubungan dengan permintaan laporan PPAK mengenai Data Pengirim (Sender) atas transaksi transfer dana:</p> <ol style="list-style-type: none"> <li>Tambah parameter originatorInfos.</li> <li>Tambah parameter originatorCustomerNo.</li> <li>Tambah parameter originatorCustomerName.</li> <li>Tambah parameter OriginatorBankCode</li> </ol> <p>Response Body</p> <p>1. Tambah field parameter sehubungan dengan permintaan laporan PPAK mengenai Data Pengirim (Sender) atas transaksi transfer dana:</p> <ol style="list-style-type: none"> <li>Tambah parameter originatorInfos.</li> <li>Tambah parameter originatorCustomerNo.</li> <li>Tambah parameter originatorCustomerName.</li> </ol> <p>Contoh request dan Response: Tambah contoh originatorInfos.</p>
		9	Request for Payment	19	API Request for Payment	<p>4.2.2.3. Request for Payment</p> <p>Request Body</p> <p>1. Parameter expiredDatetime:</p> <ol style="list-style-type: none"> <li>Ubah datatype dari "Datetime" menjadi "String".</li> <li>Ubah length dari "Follow ISO 8601" menjadi "25".</li> <li>Tambah informasi pada Description.</li> <li>Ubah Example.</li> </ol> <p>2. Parameter feeType:</p> <ol style="list-style-type: none"> <li>Tambah informasi di Description</li> <li>Ubah example.</li> </ol>
		10	Interbank Transfer - Bulk	20	API Trigger Interbank Bulk Transfer	<p>4.2.2.4. Interbank Transfer - Bulk</p> <p>a. Interbank Bulk Transfer</p> <p>1. Hapus kata "Trigger" pada nama Sub-API, keterangan Sequence diagram dan Informasi umum bagian Name menjadi "Api Interbank Bulk Transfer".</p> <p>Request Body</p> <p>1. Parameter feeType:</p> <ol style="list-style-type: none"> <li>Tambah informasi di Description</li> <li>Ubah example.</li> </ol> <p>2. Parameter transactionDate: Tambah informasi di Description.</p> <p>3. Parameter bulkObject: Ubah data Type dari "Array" menjadi "Array of Object".</p> <p>4. Tambah field parameter sehubungan dengan permintaan laporan PPAK mengenai Data Pengirim (Sender) atas transaksi transfer dana:</p> <ol style="list-style-type: none"> <li>Tambah parameter originatorInfos.</li> <li>Tambah parameter originatorCustomerNo.</li> <li>Tambah parameter originatorCustomerName.</li> <li>Tambah parameter OriginatorBankCode</li> </ol>
				21	API Trigger Interbank Bulk Transfer - Notify	<p>4.2.2.4. Interbank Transfer - Bulk</p> <p>b. Notify</p> <p>1. Ubah nama keterangan Sequence diagram dan Informasi umum bagian Name menjadi "API Interbank Bulk Transfer - Notification".</p> <p>Request Body</p> <p>1. Parameter bulkObject: Ubah data Type dari "Array" menjadi "Array of Object".</p>

No. API	API	No. Sub-API	Sub-API	Service Code	Sub-service	Keterangan Revisi
		11	RTGS Transfer	22	API RTGS Transfer	<p>4.2.2.5. RTGS Transfer</p> <p>a. Transfer RTGS</p> <p>Request Body</p> <ol style="list-style-type: none"> <li>Parameter beneficiaryCustomerResidence: Tambah informasi di Description.</li> <li>Parameter beneficiaryCustomerType: Tambah informasi di Description.</li> <li>Parameter feeType: <ol style="list-style-type: none"> <li>Ubah Description</li> <li>Ubah Example.</li> </ol> </li> <li>Parameter senderCustomerResidence: Tambah informasi di Description.</li> <li>Parameter senderCustomerType: Tambah informasi di Description.</li> <li>Parameter transactionDate: <ol style="list-style-type: none"> <li>Ubah informasi di Description.</li> <li>Ubah Example dari "...-07:00" menjadi "...+07:00".</li> </ol> </li> <li>Tambah field parameter sehubungan dengan permintaan laporan PPAK mengenai Data Pengirim (Sender) atas transaksi transfer dana: <ol style="list-style-type: none"> <li>Tambah parameter originatorInfos.</li> <li>Tambah parameter originatorCustomerNo.</li> <li>Tambah parameter originatorCustomerName.</li> <li>Tambah parameter OriginatorBankCode</li> </ol> </li> </ol> <p>Response Body</p> <ol style="list-style-type: none"> <li>Parameter beneficiaryAccountType: Tambah informasi di Description.</li> <li>Parameter transactionStatus: Tambah informasi di Description.</li> </ol>
				76	API Notify RTGS	<p>4.2.2.5. RTGS Transfer</p> <p>b. Notify RTGS</p> <p>Nama Sub-API</p> <ol style="list-style-type: none"> <li>Nama Sub-API diubah dari "Notify RTGS" menjadi "RTGS Notification"</li> </ol> <p>Request Body</p> <ol style="list-style-type: none"> <li>Sub-Parameter currency dari Parameter amount: Ubah length dari "String (ISO4217)" menjadi "String"</li> <li>Parameter transactionDate: Ubah informasi pada Description</li> </ol>
		12	SKNBI Transfer	23	API SKNBI Transfer	<p>4.2.2.6 SKNBI Transfer</p> <p>a. Transfer SKNBI</p> <p>Request Body</p> <p>Sub-Parameter amount dari Parameter amount: Ubah length dari "String (ISO4217)" menjadi "String"</p> <p>Parameter feeType: Pemindahan value yang boleh diisi dari kolom Example ke kolom Description</p> <p>Parameter transactionDate:</p> <ol style="list-style-type: none"> <li>Ubah informasi pada Description</li> <li>Ubah Example dari "...-07:00" menjadi "...+07:00".</li> </ol> <p>Tambah field parameter sehubungan dengan permintaan laporan PPAK mengenai Data Pengirim (Sender) atas transaksi transfer dana:</p> <ol style="list-style-type: none"> <li>Tambah parameter originatorInfos.</li> <li>Tambah parameter originatorCustomerNo.</li> <li>Tambah parameter originatorCustomerName.</li> <li>Tambah parameter OriginatorBankCode</li> </ol> <p>Response Body:</p> <p>Sub-Parameter currency dari Parameter amount: Ubah length dari "String (ISO4217)" menjadi "String"</p> <p>Parameter transactionDate:</p> <ol style="list-style-type: none"> <li>Ubah informasi pada Description</li> <li>Ubah Example dari "...-07:00" menjadi "...+07:00".</li> </ol>
				75	API Notify SKNBI	<p>4.2.2.6 SKNBI Transfer</p> <p>a. Notify SKNBI</p> <p>Nama Sub-API</p> <ol style="list-style-type: none"> <li>Nama Sub-API diubah dari "Notify SKNBI" menjadi "SKNBI Notification"</li> </ol> <p>Request Body</p> <ol style="list-style-type: none"> <li>Sub-Parameter currency dari Parameter amount: Ubah length dari "String (ISO4217)" menjadi "String"</li> <li>Parameter transactionDate: Ubah informasi pada Description</li> </ol>
				24	API Virtual Account - Inquiry	<p>4.2.2.7 Virtual Account</p> <p>a. Inquiry</p> <p>Request Body</p> <ol style="list-style-type: none"> <li>Parameter virtualAccountNo: Ubah deskripsi dari "... left padding 0)..." menjadi "... left padding space)..."</li> <li>Sub-Parameter value dari Parameter totalAmount: <ol style="list-style-type: none"> <li>Ubah length dari "String (ISO4217)" menjadi "String"</li> <li>Ubah nama Sub-Parameter dari "Value" menjadi "value"</li> </ol> </li> <li>Sub-Parameter currency dari Parameter totalAmount: <ol style="list-style-type: none"> <li>Ubah nama Sub-Parameter dari "Currency" menjadi "currency"</li> </ol> </li> </ol> <p>Response Body</p> <ol style="list-style-type: none"> <li>Parameter virtualAccountNo: Ubah deskripsi dari "... left padding 0)..." menjadi "... left padding space)..."</li> <li>Sub-Parameter value dari Parameter totalAmount: <ol style="list-style-type: none"> <li>Ubah length dari "String (ISO4217)" menjadi "String"</li> <li>Ubah nama Sub-Parameter sesuai camelcase dari "Value" menjadi "value"</li> </ol> </li> <li>Sub-Parameter currency dari Parameter totalAmount: <ol style="list-style-type: none"> <li>Ubah nama Sub-Parameter sesuai camelcase dari "Currency" menjadi "currency"</li> </ol> </li> </ol> <p>Contoh Response</p> <ol style="list-style-type: none"> <li>Parameter virtualAccountTrxType: Ubah dari "I" menjadi "C"</li> </ol>

No. API	API	No. Sub-API	Sub-API	Service Code	Sub-service	Keterangan Revisi
				25	API Virtual Account - Payment	<p>4.2.2.7 Virtual Account b. Payment</p> <p>Request Body 1. Parameter billReferenceNo: Ubah nama Parameter sesuai camelcase dari "BillReferenceNo" menjadi "billReferenceNo"</p> <p>Request dan Response Body 1. Parameter virtualAccountNo: Ubah deskripsi dari "... left padding 0)..." menjadi "... left padding space)..." 2. Sub-Parameter value dari Parameter paidAmount, cumulativePaymentAmount, totalAmount, dan billAmount: a. Ubah length dari "String (ISO4217)" menjadi "String" b. Ubah nama Sub-Parameter dari "Value" menjadi "value" 3. Sub-Parameter currency dari Parameter paidAmount, cumulativePaymentAmount, totalAmount, dan billAmount: a. Ubah nama Sub-Parameter dari "Currency" menjadi "currency" 4. Parameter paymentType dan flagAdvice: Pemindahan value yang boleh diisi dari kolom Example ke kolom Description</p> <p>Response Body 1. Parameter paymentFlagStatus: Pemindahan value yang boleh diisi dari kolom Example ke kolom Description 2. Parameter totalAmount dan paidAmount: Perubahan tipe data dari Array of Object menjadi Object</p>
				26	API Virtual Account – Inquiry Status	<p>4.2.2.7 Virtual Account c. Inquiry Status</p> <p>Request Body 1. Parameter virtualAccountNo: Ubah deskripsi dari "... left padding 0)..." menjadi "... left padding space)..." 2. Parameter inquiryRequestId: Ubah dari M (mandatory) menjadi C (conditional)</p> <p>Response Body 1. Parameter virtualAccountNo: Ubah deskripsi dari "... left padding 0)..." menjadi "... left padding space)..." 2. Parameter paidAmount dan totalAmount: Ubah tipe data dari "Array of Object" menjadi "Object" 3. Sub-Parameter value dari Parameter paidAmount, totalAmount, dan billAmount: a. Ubah length dari "String (ISO4217)" menjadi "String" b. Ubah nama Sub-Parameter dari "Value" menjadi "value" 4. Sub-Parameter currency dari Parameter paidAmount, totalAmount, dan billAmount: a. Ubah nama Sub-Parameter dari "Currency" menjadi "currency"</p>
				27	API Virtual Account – Create VA	<p>4.2.2.7 Virtual Account d. Create VA</p> <p>Request Body 1. Parameter partnerServiceId, customerNo, dan virtualAccountNo: Ubah dari M (mandatory) menjadi O (opsional)</p> <p>Request dan Response Body 1. Parameter virtualAccountNo: Ubah deskripsi dari "... left padding 0)..." menjadi "... left padding space)..." 2. Sub-Parameter value dari Parameter totalAmount, billAmount, dan feeAmount: a. Ubah length dari "String (ISO4217)" menjadi "String" b. Ubah nama Sub-Parameter sesuai camelcase dari "Value" menjadi "value" 3. Sub-Parameter currency dari Parameter totalAmount, billAmount, dan feeAmount: a. Ubah nama Sub-Parameter sesuai camelcase dari "Currency" menjadi "currency" 4. Parameter virtualAccountTrxType: Pemindahan value yang boleh diisi dari kolom Example ke kolom Description 5. Parameter expiredDate: a. Ubah informasi pada Description b. Ubah Example dari "...:07:00" menjadi "...+07:00".</p> <p>Contoh Request 1. URL Endpoint: Ubah dari ".../inquiry" menjadi ".../create-va"</p> <p>Contoh Request dan Response 1. Parameter virtualAccountTrxType: Ubah dari "I" menjadi "C" 2. Parameter expiredDate: Ubah dari "...:07:00" menjadi "...+07:00".</p>

No. API	API	No. Sub-API	Sub-API	Service Code	Sub-service	Keterangan Revisi
		13	Virtual Account	28	API Virtual Account – Update VA	<p>4.2.2.7 Virtual Account e. Update VA</p> <p>Request dan Response Body</p> <p>1. Parameter virtualAccountNo: Ubah deskripsi dari "... left padding 0)..." menjadi "... left padding space)..."</p> <p>2. Sub-Parameter value dari Parameter totalAmount, billAmount, dan feeAmount:</p> <p>a. Ubah length dari "String (ISO4217)" menjadi "String"</p> <p>b. Ubah nama Sub-Parameter dari "Value" menjadi "value"</p> <p>3. Sub-Parameter currency dari Parameter totalAmount, billAmount, dan feeAmount:</p> <p>a. Ubah nama Sub-Parameter dari "Currency" menjadi "currency"</p> <p>4. Parameter virtualAccountTrxType: Pemindahan value yang boleh diisi dari kolom Example ke kolom Description</p> <p>5. Parameter expiredDate, lastUpdateDate, dan paymentDate:</p> <p>a. Ubah informasi pada Description</p> <p>b. Ubah Example dari "...-07:00" menjadi "...+07:00".</p> <p>Contoh Request</p> <p>1. Parameter virtualAccountTrxType: Ubah dari "1" menjadi "C"</p> <p>2. Parameter expiredDate: Ubah dari "...-07:00" menjadi "...+07:00".</p> <p>Contoh Response</p> <p>1. Parameter virtualAccountTrxType: Ubah dari "1" menjadi "C"</p> <p>2. Parameter expiredDate, lastUpdateDate, dan paymentDate: Ubah dari "...-07:00" menjadi "...+07:00".</p>
				29	API Virtual Account – Update Status VA	<p>4.2.2.7 Virtual Account f. Update Status VA</p> <p>Request dan Response Body</p> <p>1. Parameter virtualAccountNo: Ubah deskripsi dari "... left padding 0)..." menjadi "... left padding space)..."</p> <p>Response Body:</p> <p>2. Sub-Parameter value dari Parameter totalAmount dan feeAmount:</p> <p>a. Ubah length dari "String (ISO4217)" menjadi "String"</p> <p>b. Ubah nama Sub-Parameter dari "Value" menjadi "value"</p> <p>3. Sub-Parameter currency dari Parameter totalAmount dan feeAmount:</p> <p>a. Ubah nama Sub-Parameter dari "Currency" menjadi "currency"</p> <p>4. Parameter virtualAccountTrxType: Pemindahan value yang boleh diisi dari kolom Example ke kolom Description</p> <p>5. Parameter expiredDate, lastUpdateDate, dan paymentDate:</p> <p>a. Ubah informasi pada Description</p> <p>b. Ubah Example dari "...-07:00" menjadi "...+07:00".</p> <p>Contoh Response</p> <p>1. Parameter virtualAccountTrxType: Ubah dari "1" menjadi "C"</p> <p>2. Parameter expiredDate, lastUpdateDate, dan paymentDate: Ubah dari "...-07:00" menjadi "...+07:00".</p>
				30	API Virtual Account – Inquiry VA	<p>4.2.2.7 Virtual Account g. Inquiry VA</p> <p>1. Informasi umum: Ubah HTTP Method dari "GET" menjadi "POST"</p> <p>Request Body</p> <p>1. Parameter virtualAccountNo: Ubah Description dari "...left pading 0" menjadi "...left padding space".</p> <p>Response Body</p> <p>1. Parameter virtualAccountData: Ubah Data Type dari "Objecs" menjadi "Object".</p> <p>2. Parameter virtualAccountNo: Ubah Description dari "...left pading 0" menjadi "...left padding space".</p> <p>3. Ubah Parameter value dari "Value" menjadi "value".</p> <p>4. Ubah Parameter currency dari "Currency" menjadi "currency".</p> <p>5. Parameter virtualAccountTrxType:</p> <p>a. Ubah Informasi pada Description</p> <p>b. Ubah Example</p> <p>6. Parameter expiredDate: Tambah informasi pada Description.</p> <p>7. Parameter lastUpdateDate:</p> <p>a. Tambah informasi pada Description</p> <p>b. Ubah Example dari "...-07:00" menjadi "...+07:00".</p> <p>8. Parameter paymentDate:</p> <p>a. Tambah informasi pada Description</p> <p>b. Ubah Example dari "...-07:00" menjadi "...+07:00".</p> <p>Contoh Response</p> <p>1. Parameter virtualAccountTrxType: Ubah dari "1" menjadi "C"</p> <p>2. Parameter expiredDate, lastUpdateDate, dan paymentDate: Ubah dari "...-07:00" menjadi "...+07:00".</p>
				31	API Virtual Account – Delete VA	<p>4.2.2.7 Virtual Account h. Delete VA</p> <p>Request Body &amp; Response Body</p> <p>1. Parameter virtualAccountNo: Ubah Description dari "...left pading 0" menjadi "...left padding space".</p>



No. API	API	No. Sub-API	Sub-API	Service Code	Sub-service	Keterangan Revisi		
4	Transfer Credit			32	API Virtual Account – Inquiry Payment to VA from Intra Bank	<p>4.2.2.7 Virtual Account</p> <p>i. Inquiry Payment to VA from Intra Bank</p> <p>Request Body</p> <ol style="list-style-type: none"> <li>Parameter virtualAccountNo: Ubah Description dari "...left padding 0" menjadi "...left padding space".</li> <li>Ubah Parameter value dari "Value" menjadi "value".</li> <li>Ubah Parameter currency dari "Currency" menjadi "currency".</li> </ol> <p>Response Body</p> <ol style="list-style-type: none"> <li>Parameter virtualAccountNo: Ubah Description dari "...left padding 0" menjadi "...left padding space".</li> <li>Ubah Parameter value dari "Value" menjadi "value".</li> <li>Ubah Parameter currency dari "Currency" menjadi "currency".</li> <li>Parameter billAmountLabel: Ubah length dari "25?" menjadi "25".</li> <li>Parameter billAmountValue: Ubah length dari "25?" menjadi "25".</li> <li>Parameter virtualAccountTrxType: <ol style="list-style-type: none"> <li>Ubah Informasi pada Description</li> <li>Ubah Example</li> </ol> </li> <li>Ubah Parameter value dari "Value" menjadi "value".</li> <li>Ubah Parameter currency dari "Currency" menjadi "currency".</li> </ol>		
				33	API Virtual Account – Payment to VA from Intra Bank	<p>4.2.2.7 Virtual Account</p> <p>j. Payment to VA from Intra Bank</p> <p>Request Body dan Response Body</p> <ol style="list-style-type: none"> <li>Parameter virtualAccountNo: Ubah Description dari "...left padding 0" menjadi "...left padding space".</li> <li>Ubah Parameter value dari "Value" menjadi "value".</li> <li>Ubah Parameter currency dari "Currency" menjadi "currency".</li> <li>Parameter paymentType dan flagAdvise: <ol style="list-style-type: none"> <li>Ubah Informasi pada Description</li> <li>Ubah Example</li> </ol> </li> </ol>		
				34	API Virtual Account – Notification for Payment to VA from Intra Bank	<p>4.2.2.7 Virtual Account</p> <p>k. Notification for Payment to VA from Intra Bank</p> <p>Request Body dan Response Body</p> <ol style="list-style-type: none"> <li>Parameter virtualAccountNo: Ubah Description dari "...left padding 0" menjadi "...left padding space".</li> </ol>		
				35	API Virtual Account – Get Report	<p>4.2.2.7 Virtual Account</p> <p>l. Notification for Payment to VA from Intra Bank</p> <p>Response Body</p> <ol style="list-style-type: none"> <li>Parameter virtualAccountNo: Ubah Description dari "...left padding 0" menjadi "...left padding space".</li> <li>Sub-Parameter value dari Parameter totalAmount, feeAmount, dan billAmount: <ol style="list-style-type: none"> <li>Ubah length dari "String (ISO4217)" menjadi "String"</li> <li>Ubah nama Sub-Parameter dari "Value" menjadi "value"</li> </ol> </li> <li>Sub-Parameter currency dari Parameter totalAmount, feeAmount, billAmount: <ol style="list-style-type: none"> <li>Ubah nama Sub-Parameter dari "Currency" menjadi "currency"</li> </ol> </li> </ol>		
				36	API Transaction Status Inquiry	<p>4.2.3 Transaction Status Inquiry</p> <p>Request dan Response Body</p> <ol style="list-style-type: none"> <li>Parameter transactionDate: <ol style="list-style-type: none"> <li>Tambah informasi pada Description</li> <li>Ubah Example dari "...:07:00" menjadi "...+07:00".</li> </ol> </li> </ol> <p>Response Body dan Contoh Response</p> <ol style="list-style-type: none"> <li>Parameter previousResponseCode: Ubah contoh pada kolom Example</li> </ol>		
		14	API Customer Top Up			37	API Account Inquiry - CustomerTop Up	<p>4.3.1 API Customer Top Up</p> <p>a. Account Inquiry</p> <p>Sequence Diagram</p> <ol style="list-style-type: none"> <li>Ubah PJP AIS Lembaga Selain Bank menjadi PJP AIS</li> </ol> <p>Request Body</p> <ol style="list-style-type: none"> <li>Parameter customerNumber: Tambah informasi pada description</li> <li>Parameter transactionDate: <ol style="list-style-type: none"> <li>Ubah data type menjadi String</li> <li>Menambahkan keterangan pada kolom Description</li> </ol> </li> </ol> <p>Response body</p> <ol style="list-style-type: none"> <li>Parameter referenceNo: Hapus informasi pada description "Must be filled upon..."</li> </ol>
						38	API Customer Top Up	<p>4.3.1 API Customer Top Up</p> <p>b. Customer Top Up</p> <p>Sequence Diagram</p> <ol style="list-style-type: none"> <li>Ubah PJP AIS Lembaga Selain Bank menjadi PJP AIS</li> </ol> <p>Request Body</p> <ol style="list-style-type: none"> <li>Sub-Parameter value dari Parameter amount dan feeAmount: Ubah length dari "String (ISO4217)" menjadi "String"</li> <li>Parameter transactionDate: <ol style="list-style-type: none"> <li>Ubah data type menjadi String</li> <li>Menambahkan keterangan pada kolom Description</li> </ol> </li> </ol> <p>Response Body</p> <ol style="list-style-type: none"> <li>Sub-Parameter value dari Parameter amount: Ubah length dari "String (ISO4217)" menjadi "String"</li> </ol>

No. API	API	No. Sub-API	Sub-API	Service Code	Sub-service	Keterangan Revisi
				39	API Customer Top Up InquiryStatus	4.3.1 API Customer Top Up b. Customer Top Up Inquiry Status  Sequence Diagram 1. Ubah PJP AIS Lembaga Selain Bank menjadi PJP AIS  Request Body, Response Body, Contoh Request, Contoh Response 1. Parameter serviceCode: Ubah contoh pada kolom Example dari "40" menjadi "38"
		15	API Bulk Cashin	40	API Submit Bulk Cash In	4.3.2 API Bulk Cash In a. Submit Bulk  Sequence Diagram 1. Ubah PJP AIS Lembaga Selain Bank menjadi PJP AIS  Request Body 1. Parameter bulkObject: Ubah tipe data dari Object menjadi Array of Object 2. Sub-Parameter value dari Parameter amount: Ubah length dari "String (ISO4217)" menjadi "String"  Response Body Parameter bulkID: Ubah nama parameter dari bulkID menjadi bulkId
				41	API Notify Bulk Cash In	4.3.2 API Bulk Cash In b. Notify Bulk  Request Body 1. Parameter bulkObject: Ubah tipe data dari Object menjadi Array of Object 2. Sub-Parameter value dari Parameter amount: Ubah length dari "String (ISO4217)" menjadi "String"
		16	API Tranfer to Bank	42	API Transfer to Bank-AccountInquiry	4.3.3 API Transfer to Bank a. Account Inquiry  Request Body 1. Parameter PartnerReferenceNo: Ubah nama dari "PartnerReferenceNo" menjadi "partnerReferenceNo" 2. Parameter CustomerNumber: Ubah nama dari "CustomerNumber" menjadi "customerNumber"  Response Body 1. Sub-Parameter value dari parameter amount: Ubah nama dari "Value" menjadi "value"
				43	API Transfer to Bank-PaymentTransaction	4.3.3 API Transfer to Bank b. Payment Transaction  Request Body 1. Sub-Parameter value dari parameter amount: Ubah tipe data dari "String (ISO 4217)" menjadi "String"  Response Body 1. Parameter transactionDate: a. Tambah informasi pada Description b. Ubah Example dari "...:07:00" menjadi "...+07:00".
		17	API Transfer to OTC	44	API Transfer to OTC – Create Payment	4.3.4 API Transfer to OTC a. Create Payment  Sequence Diagram 1. Actor PJP AIS Lembaga Selain Bank (App): Ubah nama Actor dari "PJP AIS Lembaga Selain Bank (App)" menjadi "PJP AIS (App)" 2. Actor PJP AIS Lembaga Selain Bank (Backend): Ubah nama Actor dari "PJP AIS Lembaga Selain Bank (Backend)" menjadi "PJP AIS (Backend)"  Request Body 1. Sub-Parameter value dari parameter amount: Ubah tipe data dari "String (ISO 4217)" menjadi "String"  Response Body 1. Parameter transactionDate: a. Tambah informasi pada Description b. Ubah Example dari "...:07:00" menjadi "...+07:00".
				45	API Transfer to OTC – Transfer Status	4.3.4 API Transfer to OTC b. Transfer Status  Request dan Response Body 1. Parameter transactionDate: a. Tambah informasi pada Description b. Ubah Example dari "...:07:00" menjadi "...+07:00". 2. Parameter serviceCode: Ubah contoh pada kolom Example dari "17" menjadi "44" 3. Sub-Parameter value dari parameter amount: Ubah tipe data dari "String (ISO 4217)" menjadi "String"  Contoh Request dan Response 1. Parameter serviceCode: Ubah value dari "17" menjadi "44"
				46	API Transfer to OTC – Cancel Payment	4.3.4 API Transfer to OTC c. Cancel Payment  Response Body 1. Parameter transactionDate: a. Tambah informasi pada Description b. Ubah Example dari "...:07:00" menjadi "...+07:00". c. Ubah length dari 255 menjadi 25

No. API	API	No. Sub-API	Sub-API	Service Code	Sub-service	Keterangan Revisi
				47	API Generate QR MPM	<p>4.3.5 API QR MPM a. Generate QR</p> <p>Request Body</p> <ol style="list-style-type: none"> <li>Sub-Parameter value dari parameter amount dan feeAmount: Ubah tipe data dari "String (ISO 4217)" menjadi "String"</li> <li>Parameter FeeAmount: Ubah nama dari "FeeAmount" menjadi "feeAmount"</li> <li>Parameter validityPeriod: <ol style="list-style-type: none"> <li>Penambahan deskripsi</li> <li>Ubah Example dari "...-07:00" menjadi "...+07:00".</li> </ol> </li> </ol>
				48	API Decode QR MPM	<p>4.3.5 API QR MPM b. Decode QR</p> <p>Request Body</p> <ol style="list-style-type: none"> <li>Sub-Parameter currency dari parameter amount: Ubah tipe data dari "String (ISO 4217)" menjadi "String"</li> <li>Parameter scanTime: Penambahan deskripsi</li> </ol> <p>Response Body</p> <ol style="list-style-type: none"> <li>Parameter referenceNo: Ubah Mandatory dari "C, Mandatory if redirect" menjadi "C"</li> <li>Parameter redirectUrl: <ol style="list-style-type: none"> <li>Ubah Mandatory dari "C, Mandatory if redirect mode" menjadi "C"</li> <li>Tambah di kolom Description "Mandatory if H2H mode"</li> </ol> </li> <li>Parameter merchantName: <ol style="list-style-type: none"> <li>Ubah Mandatory dari "C, Mandatory if host mode" menjadi "C"</li> <li>Tambah di kolom Description "Mandatory if H2H mode"</li> </ol> </li> <li>Parameter merchantCategory: <ol style="list-style-type: none"> <li>Ubah Mandatory dari "C, Mandatory if host mode" menjadi "C"</li> <li>Tambah di kolom Description "Mandatory if H2H mode"</li> </ol> </li> <li>Parameter merchantLocation: <ol style="list-style-type: none"> <li>Ubah Mandatory dari "C, Mandatory if host mode" menjadi "C"</li> <li>Tambah di kolom Description "Mandatory if H2H mode"</li> </ol> </li> <li>Penambahan parameter baru yaitu parameter "merchantInfos"</li> <li>Sub-Parameter currency dari parameter transactionAmount dan feeAmount: Ubah tipe data dari "String (ISO 4217)" menjadi "String"</li> </ol>
				49	API Payment Redirect	<p>4.3.5 API QR MPM c. Payment Redirect - Apply OTT</p> <p>Request Body</p> <ol style="list-style-type: none"> <li>Parameter userResources: Ubah tipe data dari "String Array" menjadi "Array of String"</li> </ol> <p>Response Body</p> <ol style="list-style-type: none"> <li>Parameter resourcesType: Ubah tipe data dari "String Array" menjadi "Array of String"</li> </ol> <p>Contoh Response</p> <p>1. Parameter resourceType: Ubah nama parameter dari "resourceType" menjadi "resourcesType"</p>
				50	API Payment – Host to Host	<p>4.3.5 API QR MPM d. Payment - Host to Host</p> <p>Request Body</p> <ol style="list-style-type: none"> <li>Sub-Parameter currency dari parameter amount dan feeAmount: Ubah tipe data dari "String (ISO 4217)" menjadi "String"</li> <li>Parameter otp: Ubah data type dari "C" menjadi "O"</li> </ol> <p>Response Body</p> <ol style="list-style-type: none"> <li>Parameter transactionDate: <ol style="list-style-type: none"> <li>Tambah informasi pada Description</li> <li>Ubah Example dari "...-07:00" menjadi "...+07:00".</li> <li>Ubah length dari 255 menjadi 25</li> </ol> </li> <li>Sub-Parameter currency dari parameter amount dan feeAmount: Ubah tipe data dari "String (ISO 4217)" menjadi "String"</li> </ol>
		18	API QR MPM	51	API Query Payment	<p>4.3.5 API QR MPM e. Query Payment</p> <p>Request Body</p> <ol style="list-style-type: none"> <li>Parameter externalStoreID: Ubah nama parameter menjadi "externalStoreId"</li> </ol> <p>Request and Response Body</p> <ol style="list-style-type: none"> <li>Parameter serviceCode: Ubah contoh pada kolom Example dari "17" menjadi "47/49/50"</li> </ol> <p>Response Body</p> <ol style="list-style-type: none"> <li>Parameter paidTime: <ol style="list-style-type: none"> <li>Ubah tipe data menjadi "String"</li> <li>Ubah length dari 255 menjadi 25</li> <li>Penambahan kondisi pada kolom Description</li> <li>Tambah "...+07:00" pada kolom Example</li> </ol> </li> <li>Sub-Parameter currency dari parameter amount dan feeAmount: Ubah tipe data dari "String (ISO 4217)" menjadi "String"</li> </ol> <p>Contoh Request</p> <ol style="list-style-type: none"> <li>Parameter serviceCode: Ubah contoh pada kolom Example dari "17" menjadi "47"</li> <li>Parameter externalStoreID: Ubah nama parameter menjadi "externalStoreId"</li> </ol> <p>Contoh Response</p> <ol style="list-style-type: none"> <li>Parameter serviceCode: Ubah contoh pada kolom Example dari "17" menjadi "47"</li> <li>Parameter paidTime: Tambah "...+07:00"</li> </ol>

No. API	API	No. Sub-API	Sub-API	Service Code	Sub-service	Keterangan Revisi
				52	API Payment Notify	<p>4.3.5 API QR MPM f. Payment Notify</p> <p>Ubah nama Sub-API dari "API Payment Notify" menjadi "API Payment Notification"</p> <p>Request Body</p> <ol style="list-style-type: none"> <li>Parameter sessionId: Ubah nama parameter menjadi "sessionId"</li> <li>Parameter externalStoreID: Ubah nama parameter menjadi "externalStoreId"</li> <li>Sub-Parameter currency dari parameter amount: Ubah tipe data dari "String (ISO 4217)" menjadi "String"</li> </ol> <p>Contoh Request</p> <ol style="list-style-type: none"> <li>Parameter sessionId: Ubah nama parameter menjadi "sessionId"</li> <li>Parameter externalStoreID: Ubah nama parameter menjadi "externalStoreId"</li> </ol>
				77	API Cancel Payment	<p>4.3.5 API QR MPM g. Cancel Payment</p> <p>Request Body</p> <ol style="list-style-type: none"> <li>Sub-Parameter currency dari parameter amount: Ubah tipe data dari "String (ISO 4217)" menjadi "String"</li> </ol> <p>Response Body</p> <ol style="list-style-type: none"> <li>Parameter cancelTime: <ol style="list-style-type: none"> <li>Penambahan kondisi pada kolom Description</li> <li>Penambahan "...+07:00" pada kolom Example</li> </ol> </li> <li>Parameter transactionDate: <ol style="list-style-type: none"> <li>Tambah informasi pada Description</li> <li>Penambahan "...+07:00" pada kolom Example</li> <li>Ubah length dari 255 menjadi 25</li> </ol> </li> </ol> <p>Contoh Response</p> <ol style="list-style-type: none"> <li>Parameter cancelTime: Penambahan "...+07:00"</li> <li>Parameter transactionDate: Ubah value menjadi "2020-12-23T08:37:11+07:00"</li> </ol>
				78	API Refund Payment	<p>4.3.5 API QR MPM h. Refund Payment</p> <p>Request dan Response Body</p> <ol style="list-style-type: none"> <li>Sub-Parameter currency dari parameter refundAmount: Ubah tipe data dari "String (ISO 4217)" menjadi "String"</li> </ol> <p>Response Body</p> <ol style="list-style-type: none"> <li>Parameter originalReferenceNo: Ubah Mandatory dari "C" menjadi "O"</li> <li>Parameter referenceNo: Ubah nama parameter dari "referenceNo" menjadi "refundNo"</li> <li>Parameter refundTime: Penambahan deskripsi pada kolom Description</li> </ol> <p>Contoh Response</p> <ol style="list-style-type: none"> <li>Parameter referenceNo: Ubah nama parameter dari "referenceNo" menjadi "refundNo"</li> </ol>
				53	API Transaction Status Inquiry	<p>4.3.6. API Transaction Status InquiryRequest Body</p> <ol style="list-style-type: none"> <li>Parameter serviceCode: Ubah contoh pada kolom Example dari "17" menjadi "49/50"</li> <li>Parameter transactionDate: <ol style="list-style-type: none"> <li>Tambah informasi pada Description</li> <li>Ubah Example dari "...-07:00" menjadi "...+07:00".</li> </ol> </li> <li>Sub-Parameter currency dari parameter amount: Ubah tipe data dari "String (ISO 4217)" menjadi "String"</li> </ol> <p>Response Body</p> <ol style="list-style-type: none"> <li>Parameter serviceCode: Ubah contoh pada kolom Example dari "17" menjadi "49/50"</li> <li>Parameter originalResponseCode: Ubah contoh pada kolom Example dari "2005300" menjadi "2004900/2005000"</li> <li>Parameter requestID: Ubah nama parameter dari "requestID" menjadi "requestId"</li> <li>Parameter transactionDate: <ol style="list-style-type: none"> <li>Tambah informasi pada Description</li> <li>Ubah Example dari "...-07:00" menjadi "...+07:00".</li> </ol> </li> <li>Sub-Parameter currency dari parameter amount: Ubah tipe data dari "String (ISO 4217)" menjadi "String"</li> </ol> <p>Contoh Request</p> <ol style="list-style-type: none"> <li>Parameter serviceCode: Ubah value dari "17" menjadi "49"</li> </ol> <p>Contoh Response</p> <ol style="list-style-type: none"> <li>Parameter serviceCode: Ubah value dari "17" menjadi "49"</li> <li>Parameter requestID: Ubah nama parameter dari "requestID" menjadi "requestId"</li> </ol>

No. API	API	No. Sub-API	Sub-API	Service Code	Sub-service	Keterangan Revisi
		19	API Direct Debit	54	API Direct Debit Payment	<p>5.2.1. API Direct Debit a. Direct Debit Payment</p> <p>Response Body</p> <p>1. Parameter bankCardToken: a. Tambah length menjadi "128" b. Tambah Description</p> <p>2. Parameter chargeToken: Ubah Mandatory dari "M" menjadi "O".</p> <p>3. SubParameter uri: Tambah example.</p> <p>4. Parameter feeType: a. Ubah description b. Ubah example</p> <p>Response Body</p> <p>1. Parameter webRedirectUri: a. Tambah Data Type "String" b. Tambah Mandatory "O" c. Tambah Lenght "2048"</p>
				55	API Direct Debit Payment Status	<p>5.2.1. API Direct Debit b. Payment Status</p> <p>Request body</p> <p>1. Parameter serviceCode: Ubah example dari "17" menjadi "54"</p> <p>2. Parameter transactionDate: Tambah description</p> <p>Response body</p> <p>1. Parameter approvalCode: Tambah description</p> <p>2. Parameter serviceCode: Ubah example dari "17" menjadi "54"</p> <p>3. Parameter originalResponseCode: Ubah example dari "2005500" menjadi "2005400"</p> <p>4. Parameter requestId: Ubah camelcase dari "requestID" menjadi "requestId"</p> <p>5. Parameter refundDate: Tambah informasi pada Description</p> <p>6. Parameterr paidTime: Tambah informasi pada Description</p> <p>7. Parameter partnerRefundNo: Ubah description dari "ReferenceNumber" menjadi "ReferenceNo"</p>
				56	API Direct Debit Payment Notify	<p>5.2.1. API Direct Debit c. Payment Notify</p> <p>Informasi umum: Ubah nama Sub-API dari " Direct Debit Payment Notif" menjadi "Direct Debit Payment Notification"</p> <p>Request body</p> <p>1. Parameter externalStoreID: Ubah sesuai camelcase dari "externalStoreID" menjadi "externalStoreId"</p> <p>Response body</p> <p>1. Parameter approvalCode: Tambah description</p>
				57	API Direct Debit Payment Cancel	<p>5.2.1. API Direct Debit d. Payment Cancel</p> <p>Request body</p> <p>1. Parameter originalpartnerReferenceNo: Ubah sesuai camelcase dari "originalpartnerReferenceNo" menjadi "originalPartnerReferenceNo"</p> <p>2. Parameter externalStoreID: Ubah sesuai camelcase dari "externalStoreID" menjadi "externalStoreId"</p> <p>3. Parameter Value: Ubah sesuai camelcase dari "Value" menjadi "value"</p> <p>4. Parameter Currency: Ubah sesuai camelcase dari "Currency" menjadi "currency"</p> <p>Response body</p> <p>1. Parameter cancelTime: Tambah informasi pada Description</p> <p>2. Parameter transactionDate: a. Ubah data type dari "yyyyMMddHHmms" menjadi "string" b. Tambah informasi pada Description</p>
				58	API Direct Debit Payment Refund	<p>5.2.1. API Direct Debit e. Refund Payment</p> <p>Request body</p> <p>1. Parameter externalStoreID: Ubah sesuai camelcase dari "externalStoreID" menjadi "externalStoreId"</p> <p>Response body</p> <p>1. Parameter originalReferenceNo: Tambah informasi pada Description</p> <p>2. Parameter refundNo: Ubah Description dari "Reference Number" menjadi "Refund Number"</p> <p>3. Parameter refundTime: Tambah informasi pada Description</p>
				59	API Generate QR CPM	<p>5.2.2. API QR CPM a. Generate QR</p> <p>Request body</p> <p>1. Parameter partnerTrxDate: Tambah informasi pada Description</p> <p>Response body</p> <p>1. Parameter referenceNo: Ubah Description.</p> <p>2. Parameter expiryTime: a. Ubah Mandatory dari "M" menjadi "O" b. Tambah Description c. Tambah Example</p>

No. API	API	No. Sub-API	Sub-API	Service Code	Sub-service	Keterangan Revisi
5	Transfer Debit	20	API QR CPM	60	API CPM Payment	<p>5.2.2. API QR CPM b. CPM Payment</p> <p>Request body</p> <ol style="list-style-type: none"> <li>Parameter Value: Ubah sesuai camelcase dari "Value" menjadi "value"</li> <li>Parameter Currency: Ubah sesuai camelcase dari "Currency" menjadi "currency"</li> <li>Parameter expiryTime: <ol style="list-style-type: none"> <li>Ubah data type dari "Number" menjadi "String"</li> <li>Ubah mandatory dari "M" menjadi "O"</li> <li>Tambah Description dan Example</li> </ol> </li> </ol> <p>Response body</p> <ol style="list-style-type: none"> <li>Parameter transactionDate: <ol style="list-style-type: none"> <li>Ubah data type dari "yyyyMMddHHmmss" menjadi "String"</li> <li>Ubah lenght dari "255" menjadi "25"</li> <li>Tambah description</li> </ol> </li> </ol>
				61	API Query Payment	<p>5.2.2. API QR CPM c. Query Payment</p> <p>Request body</p> <ol style="list-style-type: none"> <li>Parameter originalReferenceNo: Hapus Description "Must be filled..."</li> </ol> <p>Response body</p> <ol style="list-style-type: none"> <li>Parameter originalReferenceNo: Hapus Description "Must be filled..."</li> <li>Parameter latestTransactionStatus: Ubah data type dari "C" menjadi "M"</li> <li>Parameter paidTime: Tambah informasi pada Description</li> </ol>
				62	API Cancel Payment	<p>5.2.2. API QR CPM d. Cancel Payment</p> <p>Request body</p> <ol style="list-style-type: none"> <li>Parameter externalStoreID: Ubah sesuai camelcase dari "externalStoreID" menjadi "externalStoreId"</li> <li>Parameter Value: Ubah sesuai camelcase dari "Value" menjadi "value"</li> <li>Parameter Currency: Ubah sesuai camelcase dari "Currency" menjadi "currency"</li> </ol> <p>Response body</p> <ol style="list-style-type: none"> <li>Parameter originalReferenceNo: Tambah informasi pada Description</li> <li>Parameter cancelTime: Tambah informasi pada Description</li> <li>Parameter transactionDate: <ol style="list-style-type: none"> <li>Ubah data type dari "yyyyMMddHHmmss" menjadi "String"</li> <li>Ubah lenght dari "255" menjadi "25"</li> <li>Tambah description</li> </ol> </li> </ol>
				79	API Payment Notify	<p>5.2.2. API QR CPM e. Payment Notify</p> <p>1. Ubah Informasi umum bagian Name dari "API Payment Notify" menjadi "API Payment Notification".</p> <p>Request body dan Contoh Request</p> <ol style="list-style-type: none"> <li>Parameter sessionID: Ubah sesuai camelcase dari "sessionID" menjadi "sessionId"</li> </ol>
				80	API Refund Payment	<p>5.2.2. API QR CPM f. Refund Payment</p> <p>Response body</p> <ol style="list-style-type: none"> <li>Parameter originalPartnerReferenceNo: <ol style="list-style-type: none"> <li>Ubah mandatory dari "O" menjadi "M"</li> <li>Hapus Description "Must be filled..."</li> </ol> </li> <li>Parameter originalReferenceNo: Ubah mandatory dari "C" menjadi "O"</li> <li>Parameter refundTime: Tambah informasi pada Description</li> </ol>
		63	API Auth Payment	<p>5.2.3. API Auth Payment a. API Auth Payment</p> <p>Request body</p> <ol style="list-style-type: none"> <li>Parameter feeType: <ol style="list-style-type: none"> <li>Tambah informasi pada Description</li> <li>Ubah example</li> </ol> </li> </ol> <p>Response body</p> <ol style="list-style-type: none"> <li>Parameter paidTime: <ol style="list-style-type: none"> <li>Tambah informasi pada kolom Description</li> <li>Ubah example dari "...:00" menjadi "...+07:00"</li> </ol> </li> </ol>		
		64	API Payment Query	<p>5.2.3. API Auth Payment b. API Payment Query</p> <p>Request Body</p> <ol style="list-style-type: none"> <li>Parameter originalReferenceNo: Hapus kondisi pada kolom Description</li> <li>Parameter externalStoreID: Ubah nama dari externalStoreID menjadi "externalStoreId"</li> </ol> <p>Response Body</p> <ol style="list-style-type: none"> <li>Parameter originalReferenceNo: Hapus kondisi pada kolom Description</li> <li>Sub-Parameter currency dari parameter amount: Ubah tipe data dari "String (ISO 4217)" menjadi "String"</li> <li>Parameter paidTime: <ol style="list-style-type: none"> <li>Tambah informasi pada kolom Description</li> <li>Ubah example dari "...:00" menjadi "...+07:00"</li> </ol> </li> <li>Parameter latestTransactionStatus: Ubah kondisinya dari C (conditional) menjadi M (mandatory)</li> </ol>		

No. API	API	No. Sub-API	Sub-API	Service Code	Sub-service	Keterangan Revisi
		21	API Auth Payment	65	API Capture	<p>5.2.3 Auth Payment c. API Capture</p> <p>Request Body 1. Sub-Parameter currency dari parameter captureAmount: Ubah tipe data dari "String (ISO 4217)" menjadi "String"</p> <p>Response Body 1. Parameter originalReferenceNo: Hapus kondisi pada kolom Description 2. Parameter OriginalPartnerReferenceNo: Ubah nama dari OriginalPartnerReferenceNo menjadi originalPartnerReferenceNo 3. Parameter captureNo: Tambah kondisi pada kolom Description 4. Sub-Parameter currency dari parameter captureAmount: Ubah tipe data dari "String (ISO 4217)" menjadi "String" 5. Parameter captureTime: a. Tambah informasi pada kolom Description b. Ubah example dari "...-07:00" menjadi "...+07:00"</p>
	66			API Capture Query	<p>5.2.3 Auth Payment d. API Capture Query</p> <p>Response Body 1. Parameter originalReferenceNo: Hapus kondisi pada kolom Description 2. Sub-Parameter currency dari parameter captureAmount: Ubah tipe data dari "String (ISO 4217)" menjadi "String" 3. Parameter captureTime: a. Tambah informasi pada kolom Description b. Ubah example dari "...-07:00" menjadi "...+07:00" 4. Parameter latestCaptureStatus: Tambah kondisi pada kolom Description</p>	
	67			API Void	<p>5.2.3 Auth Payment e. API Void</p> <p>Request Body 1. Sub-Parameter currency dari parameter voidAmount: Ubah tipe data dari "String (ISO 4217)" menjadi "String"</p> <p>Response Body 1. Parameter originalReferenceNo: Hapus kondisi pada kolom Description 2. Parameter voidNo: Hapus kondisi pada kolom Description 3. Sub-Parameter currency dari parameter voidAmount: Ubah tipe data dari "String (ISO 4217)" menjadi "String" 4. Parameter voidTime: a. Tambah informasi pada kolom Description b. Ubah example dari "...-07:00" menjadi "...+07:00"</p>	
	68			API Void Query	<p>5.2.3 Auth Payment f. API Void Query</p> <p>Response Body 1. Parameter originalReferenceNo: Hapus kondisi pada kolom Description 2. Sub-Parameter currency dari parameter voidAmount: Ubah tipe data dari "String (ISO 4217)" menjadi "String" 3. Parameter voidTime: a. Tambah informasi pada kolom Description b. Ubah example dari "...-07:00" menjadi "...+07:00" 4. Parameter latestVoidStatus: Tambah kondisi pada kolom Description</p>	
	69			API Refund	<p>5.2.3 Auth Payment g. API Refund</p> <p>Request Body 1. Parameter originalReferenceNo: Hapus kondisi pada kolom Description 2. Parameter originalCaptureNo: Tambah kondisi pada kolom Description 3. Sub-Parameter currency dari parameter refundAmount: Ubah tipe data dari "String (ISO 4217)" menjadi "String" 4. Parameter externalStoreID: Ubah nama parameter dari externalStoreID menjadi externalStoreId</p> <p>Response Body 1. Parameter originalCaptureNo: Tambah kondisi pada kolom Description 2. Sub-Parameter currency dari parameter refundAmount: Ubah tipe data dari "String (ISO 4217)" menjadi "String" 3. Parameter refundTime: a. Tambah informasi pada kolom Description b. Ubah example dari "...-07:00" menjadi "...+07:00"</p> <p>Contoh Response 1. Parameter partnerReferenceNo: Ubah nama parameter dari partnerReferenceNo menjadi originalPartnerReferenceNo</p>	
				70	API Registrasi e-Mandate	<p>5.2.5 API Direct Debit BI-FAST a. Registrasi E-Mandate</p> <p>Request Body 1. Sub-Parameter currency dari parameter maxAmount: Ubah tipe data dari "String (ISO 4217)" menjadi "String" 2. Parameter billerID: Ubah nama parameter dari billerID menjadi billerId 3. Parameter expiredDatetime: a. Ubah tipe data dari "Datetime" menjadi "String" b. Ubah length dari "Follow ISO-8601" menjadi "25" c. Tambah informasi pada kolom Description</p>

No. API	API	No. Sub-API	Sub-API	Service Code	Sub-service	Keterangan Revisi
		22	API Direct Debit BI-FAST	71	API Trigger Direct Debit Transfer	5.2.5 API Direct Debit BI-FAST b. Trigger Direct Debit Transfer  Request Body 1. Parameter transactionDate: a. Tambah informasi pada kolom Description b. Ubah example dari "...:07:00" menjadi "...+07:00" 2. Sub-Parameter currency dari parameter amount: Ubah tipe data dari "String (ISO 4217)" menjadi "String"
				72	API Notify	5.2.5 API Direct Debit BI-FAST c. Notify  Request Body 1. Sub-Parameter currency dari parameter amount: Ubah tipe data dari "String (ISO 4217)" menjadi "String"



-Halaman akhir-